

**Technical features**

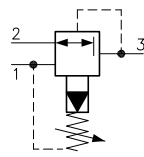

Cavity (For dimensions see catalogue 17.000)	S 50/3
Max. flow (l/min.)	90
Max. inlet pressure (bar)	420
Pressure setting range (bar)	14 - 420
Max. drain (l/min.)	0.4 - 0.6
Fluid viscosity range (cSt)	2.8 - 380
Fluid temperature range (°C)	-20 +80
Mass (kg)	0.400
Standard setting obtained with 1 l/min.	
Hydraulic fluid; mineral oil HM and HV ISO 6074	
Recommended filtration; 19/15 ISO 4466 (25 μ absolutes)	
Standard seals in Polyurethane and Buna N	

**Dimensions**

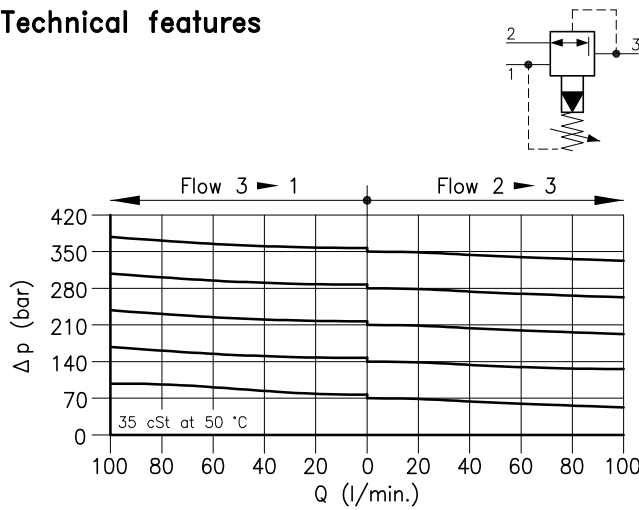
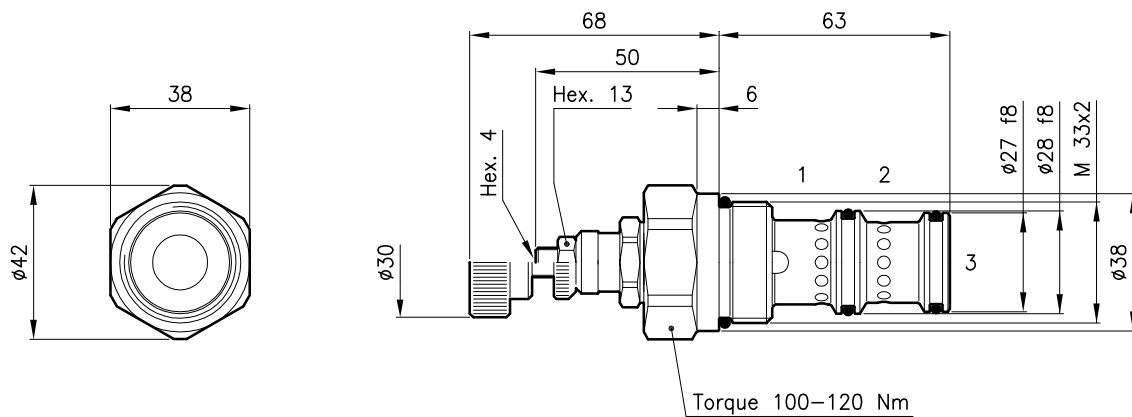

**Ordering informations**

**RLP 50/D-N**

RLP 50 = Valve type

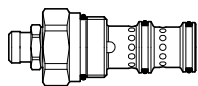

Standard spring

Type	Setting range	Factory set
<b>D</b>	14 - 210 bar	140 bar
<b>Q</b>	105 - 420 bar	315 bar

Adjustment type

- N** = Standard adjustment
- V** = Handknob adjustment

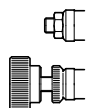

Codes:

RLP 50/D-N	51 011 109
RLP 50/Q-N	51 011 159
RLP 50/D-V	51 011 110
RLP 50/Q-V	51 011 160
External seals kit	90 620 107

RLP 50 valves can be assembled on standard bodies 50-C3 series; for dimensions see catalogue 16.010