



ENAPART



93 S Railroad Avenue Unit C
Bergenfield NJ 07621 USA
www.enapart.com
sales@enapart.com



Via del Canneto 35,
Borgosatollo, Brescia - Italia
www.enapart.it
vendite@enapart.it



Barbaros Mah. Ihlamur Bul. Aĝaoĝlu
My Newwork No:3/15 Ataşehir / İstanbul
www.enapart.net
satis@enapart.net



PRIVADA 10 B SUR #3908 COL.
ANZUREZ, C.P. 72530, PUEBLA, PUE
www.enapart.com.mx
sales@enapart.com.mx



Friedrich-Ebert-Anlage 36, 60325
Frankfurt am Main, Germany
www.enapart.de
anfrage@enapart.de



4 boulevard Carnot, 95400
villiers-le-bel, Paris, France
www.enapart.fr
sales@enapart.fr



65049, ОДЕСА, ВУЛИЦЯ ІВАНА
ФРАНКА, БУДИНОК 55, ПОВЕРХ 3
www.enapart.com.ua
sales@enapart.com.ua



MUNICIPIUL BUCUREȘTI, SECTOR 3,
B-DUL BASARABIA, NR.250, CORP P+5
www.enapart.ro
sales@enapart.ro



〒584-0023 大阪府富田林市若松町
東2丁目2番16号
www.enapart.co.jp
sales@enapart.co.jp



PLAZA NUESTRA SEÑORA DE LAS
NIEVES 12 ,LOCAL ,50012,ZARAGOZA
www.enapart.es
ventas@enapart.es



Складова база „Онгъл“, Склад А2, п.к.
4006, гр. Пловдив, България
www.enapart.bg
sales@enapart.bg



3 Austin Mews, High Street, Hemel
Hempstead, HP1 3AF , United Kingdom
www.enapart.co.uk
sales@enapart.co.uk

ELECTRIC PUMPS

ENGLISH



Index

Company profile	1
Declaration of Conformity	2
Production program	3
Use, component and materials tables.....	4-5
Hydraulic performance tables, standard running pumps.....	6-7
Hydraulic performance tables, HPP pumps	8
IMM 40 - 50 pumps datasheet.....	10-11
IMM 63 pumps datasheet	12-13
IMM 71 pumps datasheet	14-15
IMM 80 pumps datasheet	16-17
IMM 90-100 pumps datasheet.....	18-19
SPV 12-18 pumps datasheet.....	20-21
SPV 25-33 pumps datasheet.....	22-23
SPV 50-75 pumps datasheet.....	24-25
SPV 100-150 pumps datasheet.....	26-27
SP 12-18 pumps datasheet	28-29
SP 25-33 pumps datasheet	30-31
SP 50-75 pumps datasheet	32-33
SP 100-150 pumps datasheet.....	34-35
SQ pumps datasheet	36-37
AU pumps datasheet	38-39
TR pumps datasheet.....	40-41
AP 80-90 pumps closed impeller datasheet	42-43
AP 100-112 pumps closed impeller datasheet	44-45
AP 90 pumps open impeller datasheet.....	46-47
AP 100-112 pumps open impeller datasheet	48-49
MP 63-71 pumps datasheet.....	50-51
MP 80-90-100 pumps datasheet	52-53
MPC pumps datasheet	54-55
MSPV 71-80 pumps datasheet	56-57
EPC 63-71 pumps datasheet.....	58-59
EPC 80-90 pumps datasheet.....	60-61
PPI pumps datasheet.....	62-63
HPP 80 multistage pumps datasheet	64
HPP 90 multistage pumps datasheet	65
HPP 100 multistage pumps datasheet	66
HPP 112 multistage pumps datasheet	67
Use and maintenance	69-73
Troubleshooting guidelines	74
Additional information c 	74
Our foreign partners	76

HISTORY

SACEMI WAS FOUNDED IN THE SIXTIES IN MILAN, BUT IT WAS IN 1995 IN VENETO, AND MORE PRECISELY IN NOVENTA DI PIAVE (VENICE), THAT IT CONSOLIDATED AND EXPANDED ITS PRESENCE ON THE MARKET OF ELECTRIC PUMPS FOR MACHINE TOOLS.

VISION & MISSION

IN CLOSE COOPERATION WITH THE MAIN MANUFACTURERS TO FULFILL THE REQUIREMENTS OF THE NEW MACHINE TOOLS AND TO DESIGN ELECTRIC PUMPS, ELECTRIC MOTORS AND THEIR COMPONENT PARTS, ACCORDING TO THE NEEDS AND WITH THE SAME CRITERIA AS THE MACHINES TO WHICH THEY BELONG.

THE GROUP

SACEMI-GAMAR SRL BELONGS TO THE MEZZALIRA INVESTMENT GROUP SPA, A DYNAMIC GROUP IN CONTINUOUS EXPANSION, WHICH INCLUDES OTHER COMPANIES REPRESENTING THE ITALIAN EXCELLENCE IN FURNITURE, MECHANICS AND PLASTIC. THE DIFFERENT INDUSTRIAL SCENARIOS OF THESE COMPANIES CREATE SYNERGIES FOR A GREATER VALORISATION OF EACH ONE, THUS ADDING VALUE TO EACH ONE OF THEM, AND STILL PRESERVING THE VALUE OF THE BRANDS, THE IDENTITY AND THE POSITIONING OF THE PRODUCTS. A HIGH LEVEL ORGANIZATION, WITH A QUALITY PRODUCTION STRUCTURE UP TO ANY CHALLENGE, COMPOSED OF A YOUNG TEAM WITH THE SAME DREAM: TO MAKE THE DIFFERENCE.

PRODUCTION

- THE PRODUCTION SITE OF SACEMI-GAMAR S.R.L., IN NOVENTA DI PIAVE (VE) EXTENDS OVER AN AREA OF 12,000 SQUARE METERS, 6,000 OF WHICH ARE COVERED.
- THE COMPANY FOCUSES ON TECHNOLOGY TO IMPROVE SPEED AND OPERATIONAL FLEXIBILITY AND ON DESIGN TO SATISFY THE MARKET DEMANDS IN REAL TIME.
- TECHNOLOGY, DESIGN AND MANUFACTURING OF MACHINE TOOLS AND EVERYTHING THAT ROTATES AROUND IT, SUCH AS ROBOTICS AND OTHER AUTOMATION SYSTEMS, ARE STRONGLY LINKED TO THE COMPONENTS, AND THE ELECTRIC PUMP AND THE ELECTRIC MOTOR ARE PART OF THEM.
- THE COMPANY IS IN CONTACT WITH VARIOUS REALITIES THAT CONSTANTLY REQUIRE NEW TECHNOLOGIES AND THEREFORE OFFERS ITSELF AS A COMPLEMENT FOR THE MANUFACTURERS OF MACHINES FOR MECHANICS, GLASS, AIR-CONDITIONING, BUILDING, AND LIQUIDS TREATMENT, CREATING AN INTEGRATION AMONG COMPONENTS, EQUIPMENT AND MACHINES.

CUSTOMIZATION DURING ALL PHASES OF THE PRODUCTION PROCESS

PROJECT DEPT.

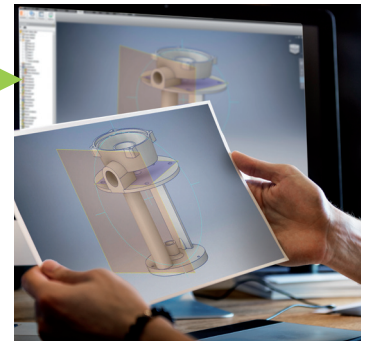

PRODUCTION



TESTING DEPT.



LOGISTIC





DECLARATION OF CONFORMITY

The undersigned manufacturer



Via Pacinotti, 2 - 30020 Noventa di Piave (VE) ITALY

01/12/2016

declares under its sole responsibility that:

the motor-driven pumps with the following trademark  **SACEMI - GAMAR**

Models: **AP - AU - EPC - HPP- IMM - MP - MPC - MSPV - PPI - SP - SPV - SQ - TR**

(All serial numbers)

are suitable for pumping non-aggressive and non-flammable liquids and are designed and constructed, as hereby declared in this Declaration of Conformity, in accordance with the provisions of the following Community Directives:

- Machinery Directive 2006/42/EC MD
- Low Voltage Directive LVD 2014/35/EU
- Electromagnetic Compatibility Directive EMC 2014/30/EU

We also hereby declare that the following technical standards have been applied for this purpose:

UNI EN ISO-12100-1; 2010: Safety of machinery – General principles for design – Risk assessment and risk reduction
 UNI EN ISO-13857; 2008: Safety of machinery, safety distances to prevent hazard zones being reached by upper and lower limbs
 UNI EN ISO-13732-1; 2007: Ergonomics of the thermal environment - Methods for the assessment of human responses to contact with surfaces - Part 1: Hot surfaces
 UNI EN 809; 2009: Pumps and pumping stations for liquids - General safety requirements
 UNI EN ISO 20361; 2009: Liquid Pumps and pump stations - Noise Test procedures - Grades 2 and 3 of accuracy
 EN - 60204-1; 2006: Safety of machinery. Electrical equipment of machines. General requirements.
 EN - 60034-1: Rotating electrical machines - Rating and performance
 EN - 60034-5: Degrees of protection provided by the integral design of rotating electrical machines
 EN - 55022: Limits and methods of measurement of radio disturbance characteristics made by Information Technology appliances
 EN - 55011 (Group 1 - Class B): Industrial, scientific and medical equipment - Radio-frequency disturbance characteristics - Limits and methods of measurement

In addition, only for the models and sizes specified in the catalogue also:

UNI EN 12157; 1999: Rotodynamic pumps - Coolant pump units for machine tools - Nominal flow rate, dimensions

Person in charge of setting up the Technical File:



Via Pacinotti, 2 - 30020 Noventa di Piave (VE) ITALY

Phone +39-0421-307389 Fax. +39-0421-65428 email: info@sacemi.com

DECLARATION OF INCORPORATION

In accordance with Annex II, Part 1, Sec. B of the Machinery Directive 2006/42/EC

The same also declares that the above products to which the following declaration of incorporation relates are partly completed machines and have been designed and manufactured in accordance with the following essential requirements of the Machinery Directive 2006/42/EC: 1.1.2, 1.1.3, 1.1.5, 1.1.6, 1.3.1, 1.3.2, 1.3.3, 1.3.4, 1.3.6, 1.3.7, 1.3.8, 1.3.9, 1.4.1, 1.4.2 (limited to 1.4.2.1), 1.5.1, 1.5.2, 1.5.4, 1.5.5, 1.5.6, 1.5.8, 1.5.10, 1.6.1 and 1.7, applicable to each type of product and that the relevant technical documentation has been compiled in accordance with Annex VIII of said Machinery Directive 2006/42/EC.

In response to a reasoned request from the national authorities, we undertake to transmit the relevant information concerning the partly completed machinery to which this declaration relates, without prejudice to our possible intellectual property rights on the product itself.

We declare that the partly completed machines referred to in this declaration **must not be put into service until the final machinery where they are to be incorporated has been declared compliant in accordance with the provisions of Machinery Directive 2006/42/EC.**

DECLARATION OF CONFORMITY

In accordance with the RoHS 2 Community Directive 2011/65/EC dated 8 June 2011

The undersigned manufacturer  Via Pacinotti, 2 - 30020 Noventa di Piave (VE) ITALY

declares under its sole responsibility that

all the components in its own production program for the motor-driven pumps with the trademark  **SACEMI - GAMAR**

Models: **AP - AU - EPC - HPP- IMM - MP - MPC - MSPV - PPI - SP - SPV - SQ - TR**

comply with the requirements of the European Parliament and the Council Directive 2011/65 / EC of 08 June 2011.

Sacemi-Gamar s.r.l.
The CEO

Production program

The production program of **SACEMI-GAMAR S.r.l.** includes a wide range of submersible, low and medium pressure, motor-driven pumps in a large number of variants designed for industrial applications mainly for use on cooling, lubrication, washing, conditioning systems and wherever an effective circulation of water-oil emulsions and pure cutting oils is required, with flow rates up to 1200 litres / min and head up to 100 metres.

In particular, submersible pumps are designed with an eye to reliability, low operating costs, safety of use and total elimination of the risk of spillage or leakage of pumped liquids.

The motor-driven pumps are equipped with 2-pole electric motors with cage rotor, closed construction, with an aluminium alloy body with molten casting, vertical axis, cooled with external ventilation, equipped with class F windings (class H on request) and a degree of protection IP55 in accordance with IEC 60034-5.

These motors are designed to operate at a voltage of 230/400 V \pm 10% and a frequency of 50 Hz at an altitude not exceeding 1000 m a.s.l. and at a maximum ambient temperature of 40°C with a relative humidity lower than 90%.

This sizing allows them to be used at 220/380 V \pm 5% and 240/415 V \pm 5% at the frequency of 50 Hz.

Should the conditions of use be more demanding (e.g. altitude greater than 1000 m and/or room temperature above 40°C), there is a decrease in the power supplied and it is advisable to consult our Technical Office.

The motor-driven pumps can be supplied with a motor both in three-phase and single-phase versions and, on demand, with special voltages and frequencies and thermal protection for heavy duty applications.

Double-screen and pre-greased rigid radial ball bearings made by leading European manufacturers are used.

The pump body can be made of steel, die-cast aluminium, cast iron, brass and plastic material.

The impeller is clamped on the extended shaft of the motor.

On request and upon verification with our Technical Office, the pumps can be equipped with IE2-IE3 efficiency class electric motors.



*on request, SP - SPV - MP - AP - IMM pumps are available
approved for the American and Canadian markets*

Use, component and materials table

Type of pump	Uses	Operating of pressure (bar)	Impurity (mm)	Type of fluid	Pump body manufacturing features			
					Length of the suction pipe (mm)	Suction pipe	Impeller-cover	Impeller
IMM 40A	Cutting-drilling	0±0.2	≤ 3	Oil-oily emulsions	80-120-150-180	PBT	PBT	Open Nylon
IMM 50A	Cutting-drilling-milling-conditioning	0±0.2	≤ 3	Oil-oily emulsions	80-120-150-180	PBT	PBT	Open Nylon
IMM 63A	Turning-filtration-milling-grinding-glass processing	0±0.6	≤ 3	Oil-oily emulsions	150-200-250-300	Aluminium	Nylon	Open Nylon
IMM 63B	Turning-filtration-milling-grinding-glass processing	0±0.8	≤ 3	Oil-oily emulsions-alkaline solutions	150-200-250-300	Aluminium	Nylon	Open Nylon
IMM 71A	Turning-filtration-milling-grinding-glass processing	0±1.2	≤ 3	Oil-oily emulsions-alkaline solutions	200-250-325-440	Aluminium	Aluminium	Open Brass 58
IMM 71B	Turning-filtration-milling-grinding-glass processing	0±1.4	≤ 3	Oil-oily emulsions-alkaline solutions	200-250-325-440	Aluminium	Aluminium	Open Brass 58
IMM 80A	Turning-filtration-milling-grinding-glass processing	0±1.4	≤ 3	Oil-oily emulsions-alkaline solutions	200-250-300-350-530	Aluminium	Aluminium	Open Brass 58
IMM 80B	Turning-filtration-milling-grinding-glass processing	0±1.6	≤ 3	Oil-oily emulsions-alkaline solutions	200-250-300-350-530	Aluminium	Aluminium	Open Brass 58
IMM 90A	Turning-filtration-milling-grinding-spray booth	0±1.0	≤ 4	Oil-oily emulsions-paint wastewater	350-450-600-800	Steel	Cast Iron G20/Steel	Open Cast Iron G20
IMM 90B	Turning-filtration-milling-grinding-spray booth	0±1.4	≤ 4	Oil-oily emulsions-paint wastewater	350-450-600-800	Steel	Cast Iron G20/Steel	Open Cast Iron G20
IMM 100B	Turning-filtration-milling-grinding-spray booth	0±1.8	≤ 4	Oil-oily emulsions-paint wastewater	350-450-600-800	Steel	Cast Iron G20/Steel	Open Cast Iron G20
SPV 12	Turning-drilling-milling-conditioning-glass processing	0±0.4	≤ 3	Oil-oily emulsions	90-120-170-220-270-350	PBT	PBT	Open PBT
SPV 18	Turning-drilling-milling-conditioning-glass processing	0±0.5	≤ 3	Oil-oily emulsions	90-120-170-220-270-350	PBT	PBT	Open PBT
SPV 25	Cutting-drilling-milling-printing-glass processing	0±0.5	≤ 3	Oil-oily emulsions-glycol	90-120-170-220-270-350	PBT	PBT	Open PBT
SPV 33	Cutting-drilling-milling-printing-glass processing	0±0.6	≤ 3	Oil-oily emulsions-glycol	90-120-170-220-270-350	PBT	PBT	Open PBT
SPV 50	Cutting-drilling-milling-printing-glass processing	0±1.2	≤ 3	Oil-oily emulsions-glycol	200-270-350	Nylon	Nylon	Open Nylon
SPV 75	Cutting-drilling-milling-printing-glass processing	0±1.4	≤ 3	Oil-oily emulsions-glycol	200-270-350	Nylon	Nylon	Open Nylon
SPV 100	Cutting-drilling-milling-printing-glass processing	0±1.4	≤ 3	Oil-oily emulsions-alkaline solutions	200-270-350	Nylon	Nylon	Open Nylon
SPV 150	Cutting-drilling-milling-printing-glass processing	0±1.5	≤ 3	Oil-oily emulsions-alkaline solutions	200-270-350	Nylon	Nylon	Open Nylon
SP 12	Milling-turning-drilling-	0±0.4	≤ 3	Oil-oily emulsions	90-120-170-220-270-350	Cast Iron G20	PBT	Open PBT
SP 18	Milling-turning-drilling-	0±0.5	≤ 3	Oil-oily emulsions	90-120-170-220-270-350	Cast Iron G20	PBT	Open PBT
SP 25	Milling-turning-drilling-grinding-filtration	0±0.5	≤ 3	Oil-oily emulsions	90-120-170-220-270-350	Cast Iron G20	PBT	Open PBT
SP 33	Milling-turning-drilling-grinding-filtration	0±0.6	≤ 3	Oil-oily emulsions	90-120-170-220-270-350	Cast Iron G20	PBT	Open PBT
SP 50	Milling-turning-drilling-grinding-filtration	0±1.2	≤ 3	Oil-oily emulsions-alkaline solutions	200-270-350-440-550	Cast Iron G20	PBT	Open PBT
SP 75	Milling-turning-drilling-grinding-filtration	0±1.2	≤ 3	Oil-oily emulsions-alkaline solutions	200-270-350-440-550	Cast Iron G20	PBT	Open PBT
SP 100	Milling-turning-drilling-grinding-filtration	0±1.2	≤ 3	Oil-oily emulsions-alkaline solutions	200-270-350-440-550	Cast Iron G20	PBT	Open PBT
SP 150	Milling-turning-drilling-grinding-filtration	0±1.5	≤ 3	Oil-oily emulsions-alkaline solutions	200-270-350-440-550	Cast Iron G20	PBT	Open PBT
SP 56	Turning-drilling-milling-surface treatment	0±0.3	≤ 3	Oil-oily emulsions-alkaline solutions	—	Nylon/Cast iron	Cast Iron	Open Nylon
SP 63	Turning-drilling-milling-surface treatment	0±0.4	≤ 3	Oil-oily emulsions-alkaline solutions	—	Nylon/Cast iron	Cast Iron	Open Nylon
SP 71A	Turning-drilling-milling-surface treatment	0±1.2	≤ 3	Oil-oily emulsions-alkaline solutions	—	Cast Iron	Cast Iron	Open Brass 58
SP 71B	Turning-drilling-milling-surface treatment	0±1.3	≤ 3	Oil-oily emulsions-alkaline solutions	—	Cast Iron	Cast Iron	Open Brass 58
SP 80A	Turning-drilling-milling-surface treatment	0±1.6	≤ 3	Oil-oily emulsions-alkaline solutions	—	Cast Iron	Cast Iron	Open Brass 58
SQ 80B	Turning-drilling-milling-surface treatment	0±1.8	≤ 3	Oil-oily emulsions-alkaline solutions	—	Cast Iron	Cast Iron	Open Brass 58
AU 56	Recirculation-suction	0±1.0	≤ 0.03	Oil-oily emulsions	—	Aluminium	Cast Iron G20	Brass 58
AU 63	Recirculation-suction	0±1.0	≤ 0.03	Oil-oily emulsions	—	Aluminium	Cast Iron G20	Brass 58
TR 71A	Recirculation-transfer	0±1.0	≤ 3	Oil-oily emulsions-alkaline solutions	—	Cast Iron	Cast Iron	Open Brass 58
TR 71B	Recirculation-transfer	0±1.3	≤ 3	Oil-oily emulsions-alkaline solutions	—	Cast Iron	Cast Iron	Open Brass 58
TR 80A	Recirculation-transfer	0±1.6	≤ 3	Oil-oily emulsions-alkaline solutions	—	Cast Iron	Cast Iron	Open Brass 58
TR 80B	Recirculation-transfer	0±1.6	≤ 3	Oil-oily emulsions-alkaline solutions	—	Cast Iron	Cast Iron	Open Brass 58

Use, component and materials table

Type of pump	Uses	Operating of pressure (bar)	Impurity (mm)	Type of fluid	Pump body manufacturing features			
					Length of the suction pipe (mm)	Suction pipe	Impeller-cover	Impeller
AP 80B	Turning-filtration-grinding-surface treatment	1.0÷2.2	≤2	Oil-oily emulsions-alkaline solutions	320-450-610-860	Cast Iron G20 Steel	Cast Iron G20	Closed Cast Iron G20
AP 90A	Turning-filtration-grinding-surface treatment	1.0÷3.0	≤2	Oil-oily emulsions-alkaline solutions	320-450-610-860	Cast Iron G20 Steel	Cast Iron G20	Closed Cast Iron G20
AP 90B	Turning-filtration-grinding-surface treatment	1.0÷3.0	≤2	Oil-oily emulsions-alkaline solutions	320-450-610-860	Cast Iron G20 Steel	Cast Iron G20	Closed Cast Iron G20
AP 100A	Turning-filtration-grinding-surface treatment	1.0÷3.6	≤2	Oil-oily emulsions-alkaline solutions	320-450-610-860	Cast Iron G20 Steel	Cast Iron G20	Closed Cast Iron G20
AP 112B	Turning-filtration-grinding-surface treatment	1.0÷3.4	≤2	Oil-oily emulsions-alkaline solutions	320-450-610-860	Cast Iron G20 Steel	Cast Iron G20	Closed Cast Iron G20
AP 90A*	Turning-filtration-grinding-surface treatment	1.0÷3.0	≤ 3	Oil-oily emulsions-alkaline solutions	320-450-610-860	Cast Iron G20 Steel	Cast Iron G20	Open* Cast Iron G20
AP 90B*	Turning-filtration-grinding-surface treatment	1.0÷3.0	≤ 3	Oil-oily emulsions-alkaline solutions	320-450-610-860	Cast Iron G20 Steel	Cast Iron G20	Open* Cast Iron G20
AP 100A*	Turning-filtration-grinding-surface treatment	1.0÷3.6	≤ 3	Oil-oily emulsions-alkaline solutions	320-450-610-860	Cast Iron G20 Steel	Cast Iron G20	Open* Cast Iron G20
AP 112B*	Turning-filtration-grinding-surface treatment	1.0÷3.4	≤ 3	Oil-oily emulsions-alkaline solutions	320-450-610-860	Cast Iron G20 Steel	Cast Iron G20	Open* Cast Iron G20

* Option

MP 63C	Turning-filtration-grinding	0÷1.6	≤ 3	Oil-oily emulsions	180-230-280-330	Aluminium	Aluminium	Open Brass 58
MP 71A	Turning-filtration-grinding	0÷1.9	≤ 3	Oil-oily emulsions	180-230-280-330	Aluminium	Aluminium	Open Brass 58
MP 71B	Turning-filtration-grinding	0÷2.3	≤ 3	Oil-oily emulsions	210-260-310-360	Aluminium	Aluminium	Open Brass 58
MP 80C	Turning-filtration-grinding	0÷3.1	≤ 3	Oil-oily emulsions	230-280-355-470	Aluminium	Aluminium	Open Brass 58
MP 90B	Turning-filtration-grinding	0÷4.9	≤ 3	Oil-oily emulsions	265-315-390-505	Aluminium	Aluminium	Open Brass 58
MP 100B	Turning-filtration-grinding	0÷6.0	≤ 3	Oil-oily emulsions	265-315-365-415-595	Aluminium	Aluminium	Open Cast Iron G20
MPC 80B	Turning-filtration-grinding	0÷2.5	≤2	Oil-oily emulsions	210-260-335-450	Aluminium	Aluminium	Closed Brass 58
MPC 80C	Turning-filtration-grinding	0÷4.5	≤2	Oil-oily emulsions	240-290-365-480	Aluminium	Aluminium	Closed Brass 58
MPC 90B	Turning-filtration-grinding	0÷6.2	≤2	Oil-oily emulsions	260-310-385-500	Aluminium	Aluminium	Closed Brass 58
MPC 100B	Turning-filtration-grinding	0÷9.8	≤2	Oil-oily emulsions	280-330-380-430-610	Aluminium	Aluminium	Closed Brass 58
MSPV 71	Milling-turning-drilling-grinding-filtration	0÷1.8	≤ 3	Oil-oily emulsions-glycol	230-300-380	Nylon	PBT	Open PBT
MSPV 80	Milling-turning-drilling-grinding-filtration	0÷4.0	≤ 3	Oil-oily emulsions-glycol	260-330-410	Nylon	PBT	Open PBT
EPC 63C	Deep-hole-drilling-cooling	0÷3.0	≤ 0.03	Oil-oily emulsions-glycol	100-130-180-230-280-360	Cast Iron G20	Cast Iron G20	Peripheral device Brass 58
EPC 71B	Deep-hole-drilling-cooling	0÷4.0	≤ 0.03	Oil-oily emulsions-glycol	100-130-180-230-280-360	Cast Iron G20	Cast Iron G20	Peripheral device Brass 58
EPC 80B	Deep-hole-drilling-cooling	0÷6.0	≤ 0.03	Oil-oily emulsions-glycol	100-130-180-230-280-360	Cast Iron G20	Cast Iron G20	Peripheral device Brass 58
EPC 90A	Deep-hole-drilling-cooling	0÷9.0	≤ 0.03	Oil-oily emulsions-glycol	115-145-195-245-295-375	Cast Iron G20	Cast Iron G20	Peripheral device Brass 58
EPC 90B	Deep-hole-drilling-cooling	0÷13	≤ 0.03	Oil-oily emulsions-glycol	140-170-220-270-320-400	Cast Iron G20	Cast Iron G20	Peripheral device Brass 58
PPI 63C	Thermoregulation	0÷3.0	≤ 0.03	Diathermic oil	195	Brass 58	Brass 58	Peripheral device Brass 58
PPI 71B	Thermoregulation	0÷4.0	≤ 0.03	Diathermic oil	200	Brass 58	Brass 58	Peripheral device Brass 58
HPP 80	Machine tool-filtration-washing-cooling	1÷5.0	–	Clean non-explosive fluids	–	Inox	–	Closed Stainless steel
HPP 90	Machine tool-filtration-washing-cooling	2÷10	–	Clean non-explosive fluids	–	Inox	–	Closed Stainless steel
HPP 100	Machine tool-filtration-washing-cooling	5÷12	–	Clean non-explosive fluids	–	Inox	–	Closed Stainless steel
HPP 112	Machine tool-filtration-washing-cooling	6÷16	–	Clean non-explosive fluids	–	Inox	–	Closed Stainless steel

Hydraulic performance tables - standard running

Delivery head (H) m →	0	0.5	1	1.5	2	3	4	5	6	7	8	9	10	12	14	16	18	20
Type of pump	Volumetric delivery (Q) l/min ↓																	
IMM 40A	13	12	10	8	5													
IMM 50A	22	19	16	13	9													
IMM 63A	85	81	77	73	69	59	47	32	8									
IMM 63B	100	97	93	89	85	77	68	58	46	32	15							
IMM 71A	238	234	229	224	220	206	197	185	172	157	143	128	109	67	4			
IMM 71B	240	235	230	226	220	210	200	190	177	166	152	140	124	67	55	6		
IMM 80A	293	288	279	276	267	256	242	229	218	202	196	179	155	116	71	14		
IMM 80B	388	383	378	372	366	355	344	332	319	303	289	275	260	224	185	140	80	
IMM 90A	928	906	870	847	816	754	709	617	551	455	341	259	119					
IMM 90B	1284	1263	1242	1220	1186	1147	1083	1039	977	914	833	766	682	484	172			
IMM 100B	1430	1406	1382	1360	1335	1280	1230	1170	1115	1050	987	920	847	710	512	304	50	

Delivery head (H) m →	0	1	2	3	4	5	6	7	8	9	10	12	14	16
Type of pump	Volumetric delivery (Q) l/min ↓													
SPV 12	56	48	38	27	13									
SPV 18	65	57	48	38	26	12								
SPV 25	72	65	57	49	37	23								
SPV 33	75	68	61	52	41	27	7							
SPV 50	263	250	238	226	213	198	182	164	147	127	103	43		
SPV 75	275	264	252	240	226	213	198	182	165	146	125	75		
SPV 100	280	269	258	246	233	220	206	192	176	159	139	89	15	
SPV 150	300	290	279	267	253	238	225	210	195	179	160	112	36	
SP 12	65	57	47	35	21									
SP 18	75	67	58	48	35	18								
SP 25	85	77	68	58	46	30	5							
SP 33	87	80	71	62	50	36	11							
SP 50	288	271	251	234	215	194	172	150	125	100	70			
SP 75	320	304	289	272	254	236	216	195	172	147	120	55		
SP 100	340	326	310	292	275	255	236	216	195	171	144	79		
SP 150	400	380	358	337	317	296	273	246	219	188	148	62		

Delivery head (H) m →	0	1	2	3	4	5	6	7	8	9	10	12	14	16
Type of pump	Volumetric delivery (Q) l/min ↓													
SQ 56	60	48	35	27	11									
SQ 63	80	69	54	41	27									
SQ 71A	260	251	241	229	218	207	185	158	134	99	52			
SQ 71B	300	289	277	264	251	235	213	190	167	141	98			
SQ 80A	340	326	310	293	274	255	238	218	195	171	130	72		
SQ 80B	380	368	354	340	326	307	293	274	257	222	208	143	62	

Delivery head (H) m →	0	1	2	3	4	5	6	7	8	9	10	12
Type of pump	Volumetric delivery (Q) l/min ↓											
AU 56	7	6	5	4	3	2	1					
AU 63	11	10	9	8	7	6	5	4	3	2	1	

Delivery head (H) m →	0	1	2	3	4	5	6	7	8	9	10	12	14	16
Type of pump	Volumetric delivery (Q) l/min ↓													
TR 71A	190	182	172	162	152	140	127	113	96	78	55			
TR 71B	200	192	183	174	164	153	141	128	115	100	82	41		
TR 80A	230	218	207	195	183	170	156	142	127	111	94	55		
TR 80B	250	240	230	220	208	196	183	169	155	140	124	88	45	

Hydraulic performance tables - standard running

Delivery head (H) m →	Type of impeller	0	10	12	14	16	18	20	22	24	26	28	30	32	34	36	38	40
Type of pump	Volumetric delivery (Q) l/min ↓																	
AP 80B	Impeller closed	240	222	207	191	173	152	129	106	65								
AP 90A		382	367	350	331	311	289	266	241	211	173	99	14					
AP 90B		525	468	449	423	400	374	346	315	276	237	192	119					
AP 100A		633	577	561	545	528	511	492	471	450	422	394	360	323	286	234	138	
AP 112B		914	786	772	752	731	706	677	629	580	506	432	346	239	73			
AP 90A	Open impeller	461	374	351	326	300	270	235	198	154	85							
AP 90B		500	436	403	369	338	309	273	233	178	68							
AP 100A		565	495	475	454	431	406	375	342	306	270	224	156					
AP 112B		984	893	865	814	765	712	655	596	528	461	372	257	48				

Delivery head (H) m →	0	4	8	12	16	20	24	28	32	36	40	45	50	55
Type of pump	Volumetric delivery (Q) l/min ↓													
MP 63C	93	79	63	43	20									
MP 71A	103	88	70	50	26									
MP 71B	115	102	88	73	55	34	8							
MP 80C	269	244	215	184	148	106	68	22						
MP 90B	307	293	276	257	236	213	187	159	130	97	63	17		
MP 100B	360	349	333	316	297	280	256	233	207	178	141	94	37	

Delivery head (H) m →	0	5	10	15	20	25	30	35	40	45	50	60	70	80	90
Type of pump	Volumetric delivery (Q) l/min ↓														
MPC 80B	131	119	109	88	58	5									
MPC 80C	151	142	134	124	118	102	93	71	40						
MPC 90B	150	152	149	145	140	135	126	118	107	94	78	40			
MPC 100B	160	156	154	152	149	146	142	135	128	121	113	93	60	27	

Delivery head (H) m →	0	2	4	6	8	10	12	14	16	18	20	22	24	26	28
Type of pump	Volumetric delivery (Q) l/min ↓														
MSPV 71	185	172	161	147	129	112	88	65	45	22					
MSPV 80	158	150	143	134	125	116	106	95	83	71	59	45	32	16	

Delivery head (H) m →	0	5	10	15	20	30	40	50	60	70	80	90	100	110	120	130
Type of pump	Volumetric delivery (Q) l/min ↓															
EPC 63C	47	37	31	23	18	6										
EPC 71B	62	56	50	44	38	27	17	6								
EPC 80B	74	68	63	57	53	43	34	25	17	9						
EPC 90A	78	72	67	62	57	47	38	30	23	15	8					
EPC 90B	80	76	73	70	67	60	54	48	41	35	29	23	17	11	5	

Delivery head (H) m →	0	5	10	15	20	25	30	35	40	45	50
Type of pump	Volumetric delivery (Q) l/min ↓										
PPI 63C	48	41	33	26	19	13	7	1			
PPI 71B	61	55	48	42	36	29	23	17	11	5	

HPP pumps hydraulic performance tables

Delivery head (H) m →	0	10	12	14	16	18	20	25	30	35	40	45	50	55	60
Type of pump	Volumetric delivery (Q) l/min ↓														
HPP 80/2		125	109	98	73	42									
HPP 80/4		147	141	138	133	127	123	106	82	46					
HPP 80/6		147	144	141	138	136	133	124	115	104	89	75	49	28	

Delivery head (H) m →	0	10	20	30	40	50	60	70	80	90	100	110
Type of pump	Volumetric delivery (Q) l/min ↓											
HPP 90/8			137	123	108	90	66	35				
HPP 90/10			145	135	125	111	98	78	54	15		
HPP 90/12			147	140	130	116	112	95	79	57	32	

Delivery head (H) m →	0	10	20	30	40	50	60	70	80	90	100	120	140	160	180
Type of pump	Volumetric delivery (Q) l/min ↓														
HPP100/14				147	141	134	126	118	109	98	84	38			
HPP112/16				149	145	140	134	126	120	110	103	80	30		
HPP112/19				151	148	142	136	132	125	119	113	99	78	43	

Datasheets motor-driven pumps

Submersible motor-driven pumps

Type IMM 40-50



Uses

They are suitable for transferring liquids containing impurities up to 3 mm in size. Their hydraulic components: impeller, feed screw and pump body in PBT allow them to be used with water, emulsions and oily substances in general, with a viscosity not exceeding 21 cSt (3° Engel). The temperature of the liquid must not exceed 70°C.

They are commonly used on:

- **machine tools** (milling and turning machines-drills)
- **glass processing machinery** (TRI version)
- **air-conditioning systems**

They are normally installed on a tank with a capacity which is proportional to their flow rate, about 2-3 cm from the bottom. It is important to make sure that the maximum liquid level in the tank is always 3-4 cm lower than the support flange (see figure).

Should the liquid be particularly dirty, it is advisable to build a compartment tank in order to allow the sludge to deposit before it is sucked by the pump.

For different uses, please consult our Technical Office.

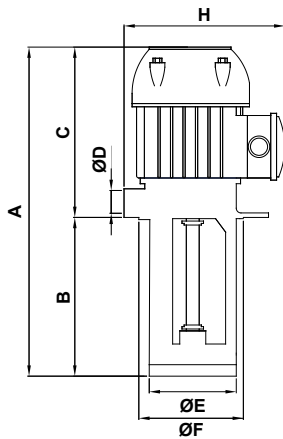

Size and weights table

Type of pump	A mm	B mm	C mm	ØD	ØE mm	ØF mm	ØG mm	H mm	ØI mm	ØL mm	Mass kg
IMM 40	224	80	144	3/8"	78	90	130	140	114	7 (n.2)	1.80
	264	120									1.83
	294	150									1.85
	324	180									1.88
IMM 50	224	80	144	3/8"	78	90	130	140	114	7 (n.2)	1.80
	264	120									1.83
	294	150									1.85
	324	180									1.88

Rating plate data

Type of pump	kW		V 230/400 - Hz 50			Q - maxQ litres/min	maxH - H metres
	Input (P1)	Nom. (P2)	In Amp.	n min ⁻¹	cos φ		
IMM 40	0.07	0.03	0.35/0.20	2730	0.58	5 - 13	2.0 - 0
IMM 50	0.09	0.04	0.35/0.20	2620	0.60	3 - 22	2.5 - 0

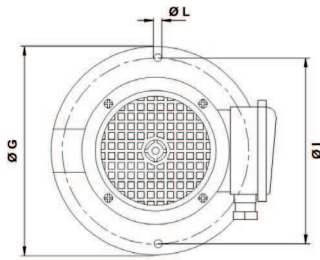

Hydraulic performance curves (open impeller)

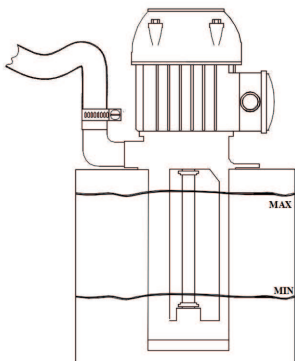
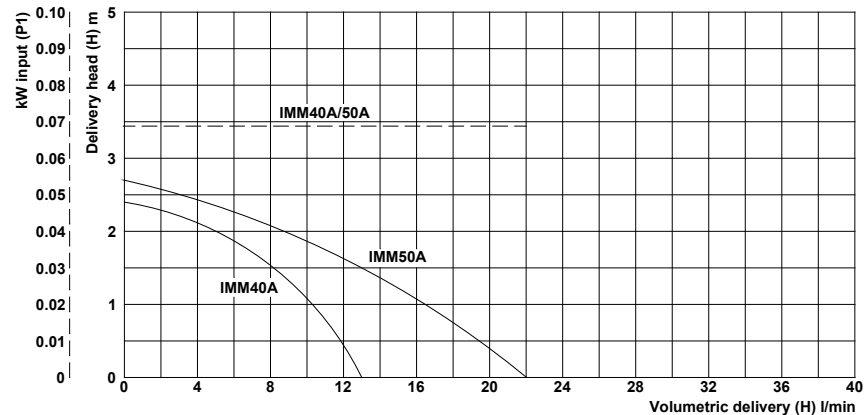

Hydraulic performance table (open impeller)

Type of pump	Volumetric delivery (Q) l/min ↓										
	0	0.5	1.0	1.5	2.0	2.5	3.0	3.5	4.0	4.5	5.0
IMM 40	13	12	10	8	5						
IMM 50	22	19	16	13	9	3					

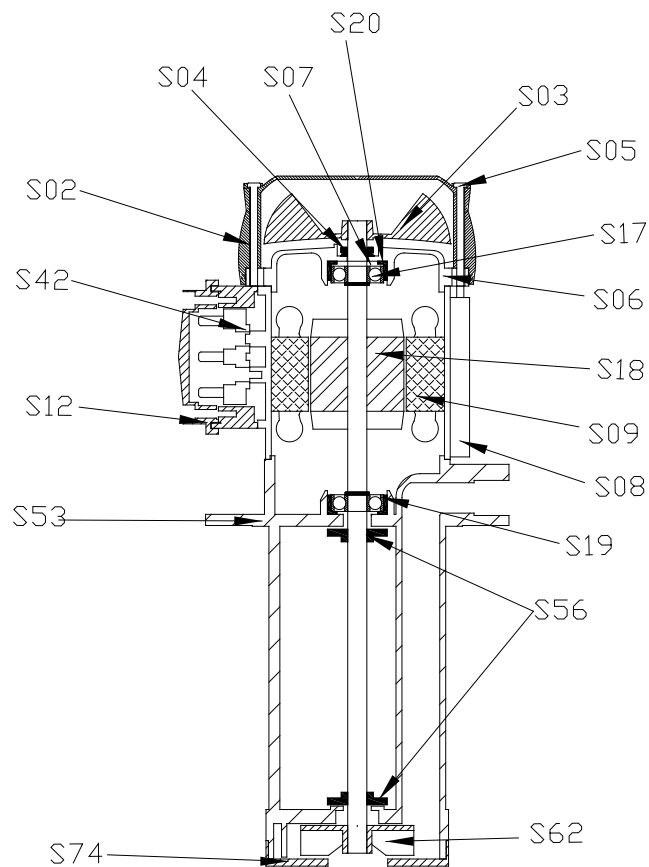

Spare parts nomenclature

Component	
S02.	Fan cover
S03.	Fan
S04.	V-ring
S05.	Stay rod
S06.	Upper shield
S07.	Spring ring
S08.	Housing
S09.	Wound stator
S12.	Terminal box
S17.	Upper bearing
S18.	Axis + rotor
S19.	Lower bearing
S20.	Bearing casing
S42.	Terminal board
S53.	Pump body
S56.	TRI washer
S62.	Impeller
S74.	Impeller-cover

IMM 40 Materials
Nylon
Nylon
NBR
Steel
Nylon
Steel
Aluminium
-
Nylon
-
Steel*
-
NBR
-
PBT
PBT
Nylon
PBT

IMM 50 Materials
Nylon
Nylon
NBR
Steel
Nylon
Steel
Aluminium
-
Nylon
-
Steel*
-
NBR
-
PBT
PBT
Nylon
PBT

*On demand
Ax.AISI316

*On demand
Ax.AISI316

Submersible motor-driven pumps

Type IMM 63



Uses

They are suitable for transferring liquids containing impurities up to 3 mm in size. Their hydraulic components: impeller and feed screw in nylon, pump body in aluminium allow them to be used with water, emulsions and oily substances in general, with a viscosity not exceeding 21 cSt (3° Engle). The temperature of the liquid must not exceed 70°C.

They are commonly used on:

- machine tools (milling and turning machines-drills)
- glass processing machinery (TRI version)
- surface treatment plants
- filtration systems
- air-conditioning systems

They are normally installed on a tank with a capacity which is proportional to their flow rate, about 4-5 cm from the bottom.

It is important to make sure that the maximum liquid level in the tank is always 3-4 cm lower than the support flange (see figure).

Should the liquid be particularly dirty, it is advisable to build a compartment tank in order to allow the sludge to deposit before it is sucked by the pump.

For different uses, please consult our Technical Office.

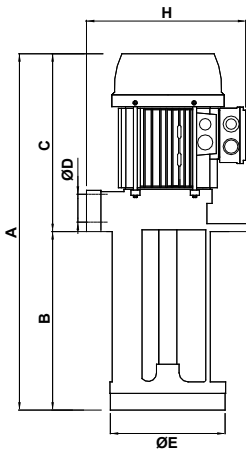

Size and weights table

Type of pump	A mm	B mm	C mm	ØD	ØE mm	ØG mm	H mm	ØI mm	ØL mm	Mass kg
IMM 63A	355	150 T	205	3/4"	128	180	190	150	9 (n.4)	5.0
	405	200 T								5.1
	455	250 T								5.3
	505	300 T								5.4
IMM 63B	355	150 T	205	3/4"	128	180	190	150	9 (n.4)	5.5
	405	200 T								5.7
	455	250 T								5.9
	505	300 T								6.0

On demand: T= TRI mode

Rating plate data

Type of pump	kW		V 230/400 - Hz 50			Q - maxQ litres/min	maxH - H metres
	Input (P1)	Nom. (P2)	In Amp.	n min ⁻¹	cos φ		
IMM 63A	0.38	0.25	1.30/0.75	2720	0.72	8 - 85	6 - 0
IMM 63B	0.52	0.37	1.65/0.95	2760	0.79	15-100	8 - 0

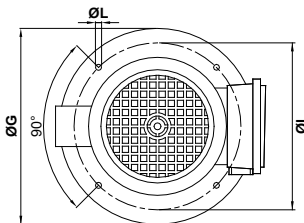

Hydraulic performance curves (open impeller)

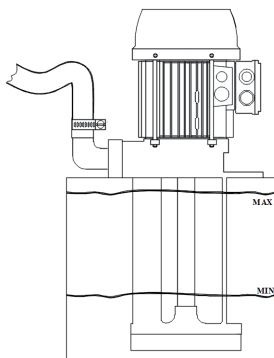
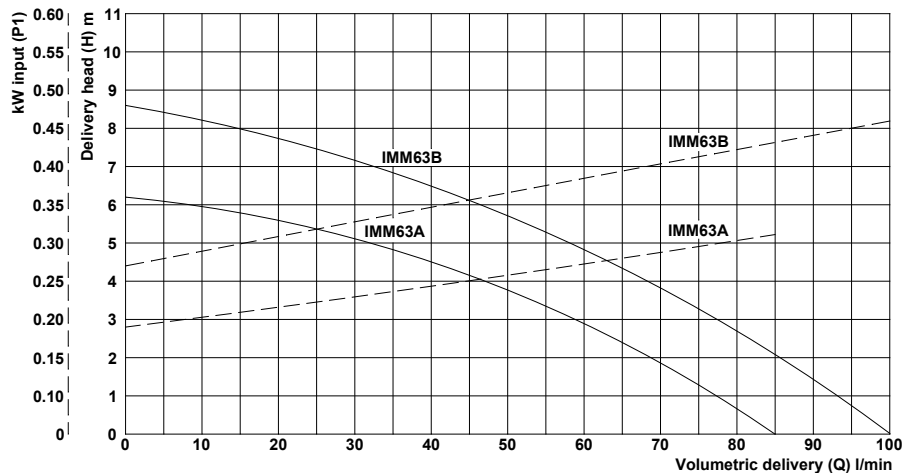

Hydraulic performance table (open impeller)

Type of pump	Volumetric delivery (Q) l/min ↓										
	0	1	2	3	4	5	6	7	8	9	10
IMM 63A	85	77	69	59	47	32	8				
IMM 63B	100	93	85	77	68	58	46	32	15		

Submersible motor-driven pumps

Type IMM 63

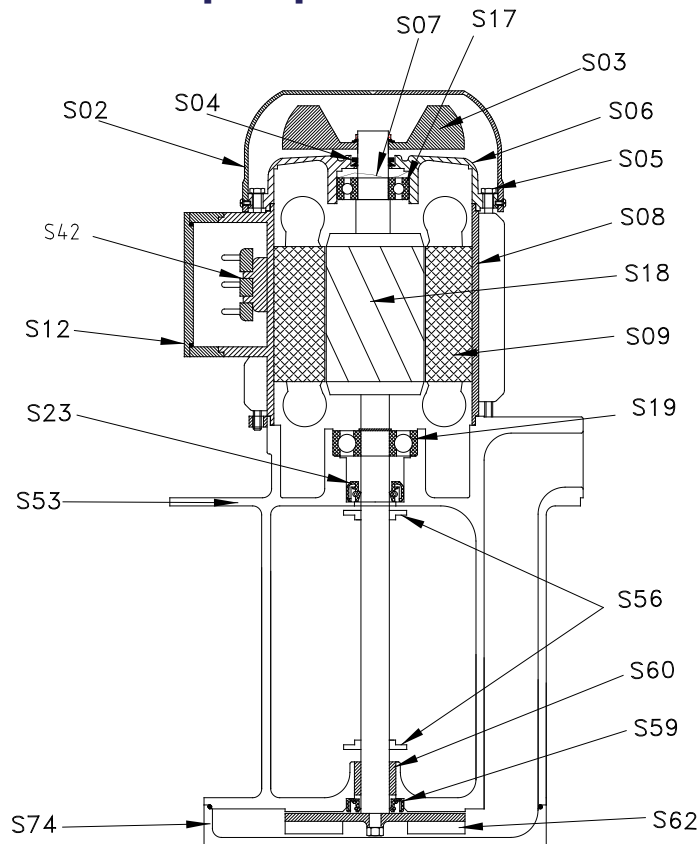

Spare parts nomenclature

Component	
S02.	Fan cover
S03.	Fan
S04.	V-ring
S05.	Stay rod
S06.	Upper shield
S07.	Spring ring
S08.	Housing
S09.	Wound stator
S12.	Terminal box
S17.	Upper bearing
S18.	Axis + rotor
S19.	Lower bearing
S23.	Motor seal ring
S42.	Terminal board
S53.	Pump body
S56.	TRI washer
S59.	Seal
S60.	Bushing
S62.	Impeller
S74.	Impeller-cover

IMM 63A Materials
Nylon*
Nylon
NBR
Steel
Aluminium
Steel
Aluminium
-
Nylon
-
Steel**
-
NBR
-
Aluminium
PBT
NBR
Bronze
Nylon
Nylon

IMM 63B Materials
Nylon*
Nylon
NBR
Steel
Aluminium
Steel
Aluminium
-
Nylon
-
Steel**
-
NBR
-
Aluminium
PBT
NBR
Bronze
Nylon
Nylon

*On demand Sheet metal

**On demand.Ax.AISI 416

*On demand Sheet metal

**On demand.Ax.AISI 416

Submersible motor-driven pumps

Type IMM 71



Uses

They are suitable for transferring liquids containing impurities up to 3 mm in size. Their hydraulic components: impeller in brass, feed screw and pump body in aluminium allow them to be used with water, emulsions and oily substances in general, with a viscosity not exceeding 21 cSt (3° Englel). The temperature of the liquid must not exceed 90°C.

- They are commonly used on:
- **machine tools** (milling and turning machines)
 - **glass processing machinery** (TRI version)
 - **surface treatment plants**
 - **filtration systems**
 - **air-conditioning systems**

They are normally installed on a tank with a capacity which is proportional to their flow rate, about 4-5 cm from the bottom.

It is important to make sure that the maximum liquid level in the tank is always 3-4 cm lower than the support flange (see figure).

Should the liquid be particularly dirty, it is advisable to build a compartment tank in order to allow the sludge to deposit before it is sucked by the pump.

For different uses, please consult our Technical Office.

Size and weights table

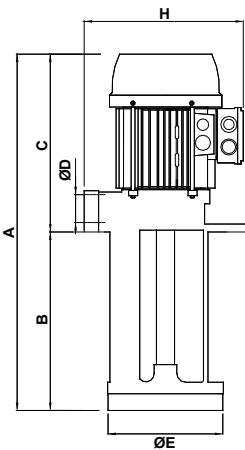

Type of pump	A mm	B mm	C mm	ØD	ØE mm	ØF mm	ØG mm	H mm	ØI mm	ØL mm	Mass kg
IMM 71A	440	200 T	240	1"	190	-	230	225	204	9 (n.5)	9.3
	490	250 T									9.7
	565	325 T									10.0
	680	440									11.3
IMM 71B	440	200 T	240	1"	190	-	230	225	204	9 (n.5)	10.2
	490	250 T									10.5
	565	325 T									10.9
	680	440									12.2

On demand: T= TRI mode

Rating plate data

Type of pump	kW		V 230/400 - Hz 50			Q - maxQ litres/min	maxH - H metres
	Input (P1)	Nom. (P2)	In Amp.	n min ⁻¹	cos φ		
IMM 71A	1.00	0.75	3.24/1.87	2770	0.77	4 - 238	14 - 0
IMM 71B	1.20	0.90	3.83/2.21	2760	0.78	6 - 240	16 - 0

Hydraulic performance curves (open impeller)

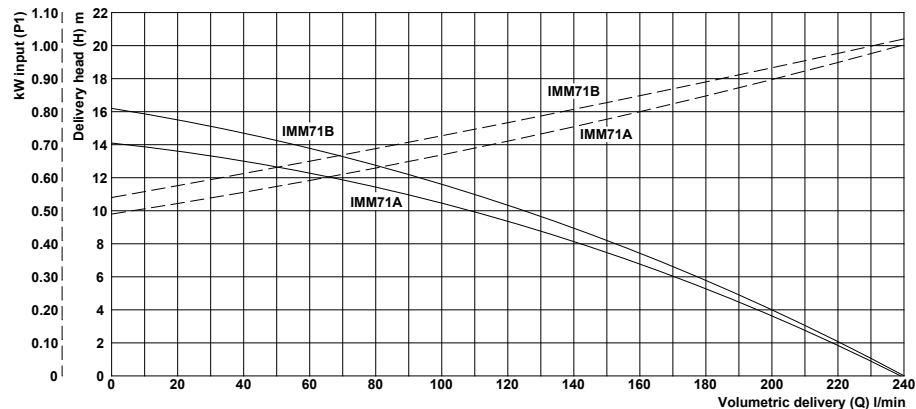

Hydraulic performance table (open impeller)

Delivery head (H) m	0	1	2	3	4	5	6	7	8	9	10	12	14	16	18
Type of pump	Volumetric delivery (Q) l/min ↓														
IMM 71A	238	229	220	206	197	185	172	157	143	128	109	67	4		
IMM 71B	240	230	220	210	200	190	177	166	152	140	124	67	55	6	

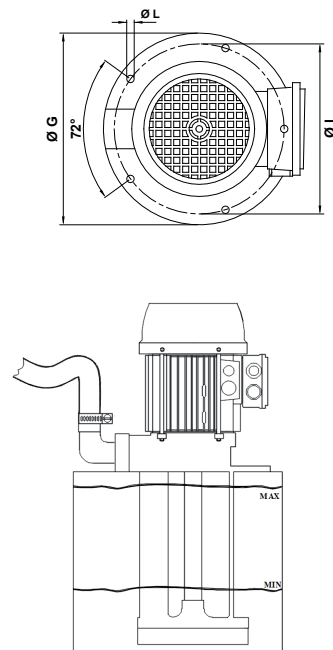

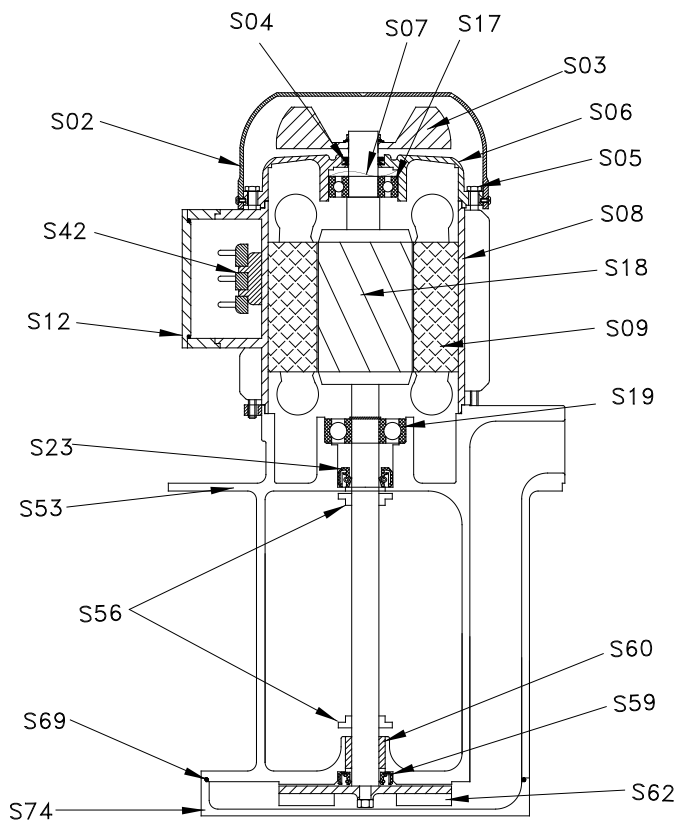

Spare parts nomenclature

Component	
S02.	Fan cover
S03.	Fan
S04.	V-ring
S05.	Stay rod
S06.	Upper shield
S07.	Spring ring
S08.	Housing
S09.	Wound stator
S12.	Terminal box
S17.	Upper bearing
S18.	Axis + rotor
S19.	Lower bearing
S23.	Motor seal ring
S42.	Terminal board
S53.	Pump body
S56.	TRI washer
S59.	Seal
S60.	Bushing
S62.	Impeller
S69.	O-ring
S74.	Impeller-cover

IMM 71A	Materials
	Nylon*
	Nylon
	NBR
	Steel
	Aluminium
	Steel
	Aluminium
	-
	Nylon
	-
	Steel**
	-
	NBR
	-
	Aluminium
	PBT
	NBR
	Bronze
	Brass 58
	NBR
	Aluminium

IMM 71B	Materials
	Nylon*
	Nylon
	NBR
	Steel
	Aluminium
	Steel
	Aluminium
	-
	Nylon
	-
	Steel**
	-
	NBR
	-
	Aluminium
	PBT
	NBR
	Bronze
	Brass 58
	NBR
	Aluminium

*On demand Sheet metal
 **On demand. Ax. AISI 416

*On demand Sheet metal
 **On demand. Ax. AISI 416

Submersible motor-driven pumps

Type IMM 80



Uses

They are suitable for transferring liquids containing impurities up to 3 mm in size. Their hydraulic components: impeller in brass, feed screw and pump body in aluminium allow them to be used with water, emulsions and oily substances in general, with a viscosity not exceeding 21 cSt (3° Engel). The temperature of the liquid must not exceed 90°C.

They are commonly used on:

- machine tools (milling and turning machines)
- glass processing machinery (TRI version)
- surface treatment plants
- filtration systems
- air-conditioning systems

They are normally installed on a tank with a capacity which is proportional to their flow rate, about 4-5 cm from the bottom.

It is important to make sure that the maximum liquid level in the tank is always 3-4 cm lower than the support flange (see figure).

Should the liquid be particularly dirty, it is advisable to build a compartment tank in order to allow the sludge to deposit before it is sucked by the pump.

For different uses, please consult our Technical Office.

Size and weights table

Type of pump	A mm	B mm	C mm	ØD	ØE mm	ØF mm	ØG mm	H mm	ØI mm	ØL mm	Mass kg
IMM 80A	485	200 T	285	1 ¼"	202	220	250	260	235	9 (n.5)	14.5
	535	250 T									15.0
	585	300 T									15.5
	635	350 T									16.0
	815	530									18.0
IMM 80B	485	200 T	285	1 ¼"	202	220	250	260	235	9 (n.5)	15.4
	535	250 T									15.9
	585	300 T									16.4
	635	350 T									16.9
	815	530									19.0

On demand: T= TRI mode

Rating plate data

Type of pump	kW		V 230/400 - Hz 50			Q - maxQ litres/min	maxH - H metres
	Input (P1)	Nom. (P2)	In Amp.	n min ⁻¹	cos φ		
IMM 80A	1.41	1.1	4.3/2.5	2825	0.81	14 - 293	16 - 0
IMM 80B	1.86	1.5	5.7/3.3	2845	0.83	80 - 388	18 - 0

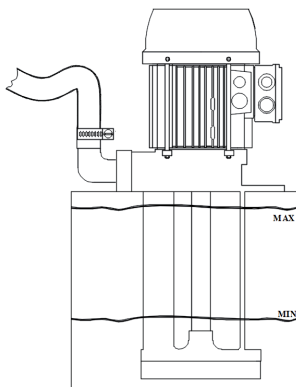
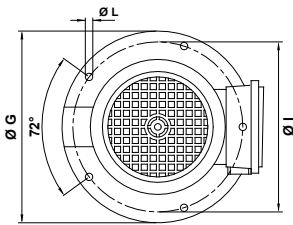
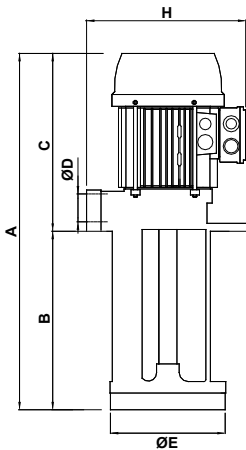

Hydraulic performance curves (open impeller)

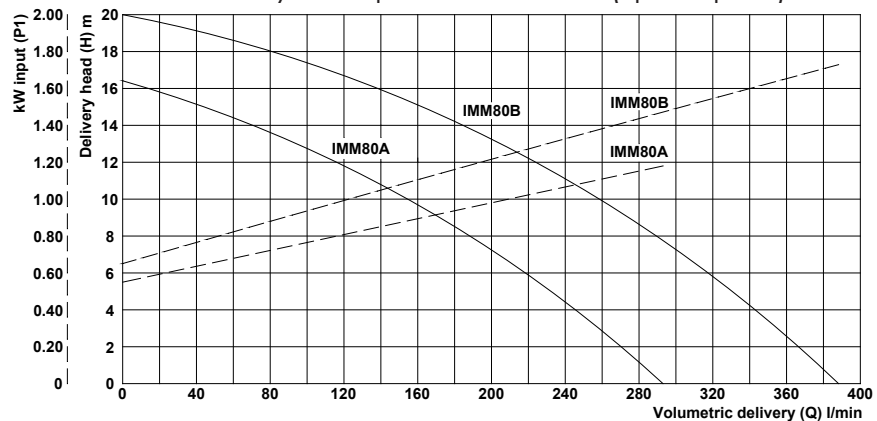

Hydraulic performance table (open impeller)

Type of pump	Volumetric delivery (Q) l/min ↓															
	0	1	2	3	4	5	6	7	8	9	10	12	14	16	18	20
IMM 80A	293	279	267	256	242	229	218	212	196	179	155	116	71	14		
IMM 80B	388	378	366	355	344	332	319	303	289	275	260	224	185	140	80	

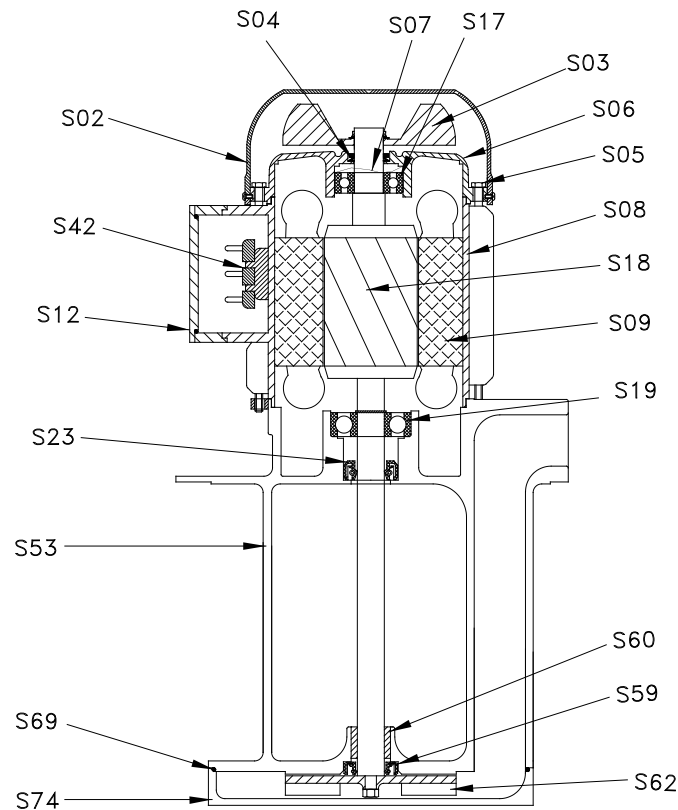

Spare parts nomenclature

Component	
S02.	Fan cover
S03.	Fan
S04.	V-ring
S05.	Stay rod
S06.	Upper shield
S07.	Spring ring
S08.	Housing
S09.	Wound stator
S12.	Terminal box
S17.	Upper bearing
S18.	Axis + rotor
S19.	Lower bearing
S23.	Motor seal ring
S42.	Terminal board
S53.	Pump body
S59.	Seal
S60.	Bushing
S62.	Impeller
S69.	O-ring
S74.	Impeller-cover

IMM 80A
Materials
Nylon*
Nylon
NBR
Steel
Aluminium
Steel
Aluminium
-
Nylon
-
Steel**
-
NBR
-
Aluminium
NBR
Bronze
Brass 58
NBR
Aluminium

*On demand Sheet metal
 **On demand Ax.AISI 416

IMM 80B
Materials
Nylon*
Nylon
NBR
Steel
Aluminium
Steel
Aluminium
-
Nylon
-
Steel**
-
NBR
-
Aluminium
NBR
Bronze
Brass 58
NBR
Aluminium

*On demand Sheet metal
 **On demand Ax.AISI 416

Submersible motor-driven pumps

Type IMM 90-100



Uses

They are suitable for transferring liquids containing impurities up to 4 mm in size. Their hydraulic components: impeller and feed screw in cast iron, pump body in steel allow them to be used with water, emulsions and oily substances in general, with a viscosity not exceeding 21 cSt (3° Englel). The temperature of the liquid must not exceed 90°C.

They are commonly used on:

- machine tools
- glass processing machinery
- surface treatment plants
- filtration systems
- spray booths

They are normally installed on a tank with a capacity which is proportional to their flow rate, about 7-8 cm from the bottom.

It is important to make sure that the maximum liquid level in the tank is always 5-6 cm lower than the support flange (see figure).

Should the liquid be particularly dirty, it is advisable to build a compartment tank in order to allow the sludge to deposit before it is sucked by the pump.

For different uses, please consult our Technical Office.

Size and weights table

Type of pump	A mm	B mm	C mm	ØD	ØE mm	ØF mm	ØG mm	H mm	ØI mm	ØL mm	Mass kg
IMM 90A	695	350	345	2"	235	240	300	130	270	13 (n.4)	47.5
	795	450									48.1
	945	600									48.8
	1145	800									50.0
IMM 90B	695	350	345	2"	235	240	300	130	270	13 (n.4)	49.0
	795	450									49.6
	945	600									50.0
	1145	800									51.5
IMM 100B	730	350	380	2 1/2"	235	240	300	145	270	13 (n.4)	53.0
	830	450									53.6
	980	600									54.3
	1180	800									55.5

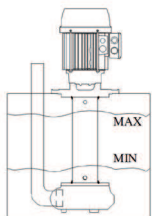
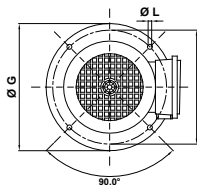
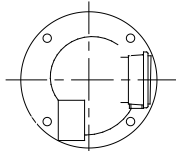
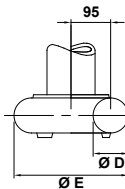
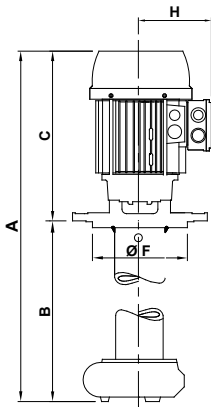

Rating plate data

Type of pump	kW		V 230/400 - Hz 50			Q - maxQ litres/min	maxH - H metres
	Input (P1)	Nom. (P2)	In Amp.	n min ⁻¹	cos φ		
IMM 90A	2.70	2.2	8.1/4.7	2870	0.83	119 - 928	10 - 0
IMM 90B	3.58	3	10.6/6.1	2855	0.84	172 - 1284	14 - 0
IMM 100B	4.85	4	14.9/8.6	2875	0.81	50 - 1430	18 - 0

Hydraulic performance curves (open impeller)

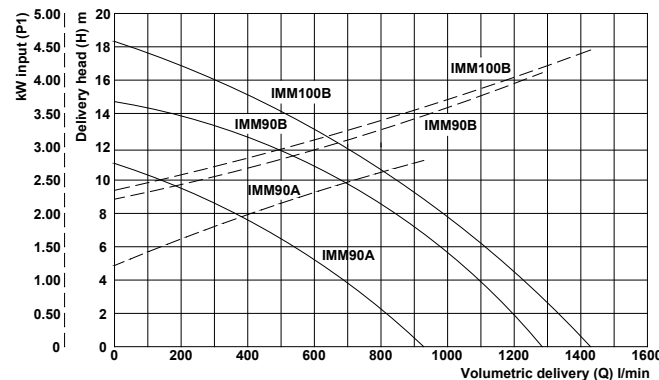

Hydraulic performance table (open impeller)

Type of pump	Volumetric delivery (Q) l/min ↓										
	0	2	4	6	8	10	12	14	16	18	20
IMM 90A	928	816	709	551	341	119					
IMM 90B	1284	1186	1083	977	833	682	484	172			
IMM 100B	1430	1335	1230	1115	987	847	710	512	304	50	

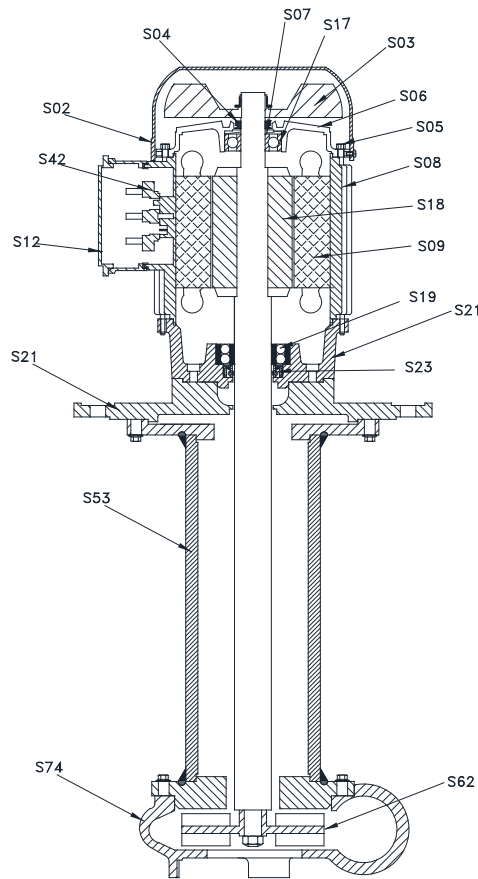

Spare parts nomenclature

Component		IMM 90A	IMM 90B	IMM 100B
		Materials	Materials	Materials
S02.	Fan cover	Nylon*	Nylon*	Nylon*
S03.	Fan	Nylon	Nylon	Nylon
S04.	V-ring	NBR	NBR	NBR
S05.	Stay rod	Steel	Steel	Steel
S06.	Upper shield	Aluminium	Aluminium	Aluminium
S07.	Spring ring	Steel	Steel	Steel
S08.	Housing	Aluminium	Aluminium	Aluminium
S09.	Wound stator	-	-	-
S12.	Terminal box	Nylon	Nylon	Nylon
S17.	Upper bearing	-	-	-
S18.	Axis + rotor	Steel	Steel	Steel
S19.	Lower bearing	-	-	-
S21.	Special shield	Cast Iron G20	Cast Iron G20	Cast Iron G20
S21.	Support flange	Cast Iron G20	Cast Iron G20	Cast Iron G20
S23.	Motor seal ring	NBR	NBR	NBR
S42.	Terminal board	-	-	-
S53.	Pump body	Steel	Steel	Steel
S62.	Impeller	Cast Iron G20	Cast Iron G20	Cast Iron G20
S74.	Impeller-cover	Cast Iron G20	Cast Iron G20	Cast Iron G20

*On demand Sheet metal

*On demand Sheet metal

*On demand Sheet metal

Submersible motor-driven pumps

Type SPV 12-18



Uses

They are suitable for transferring liquids containing impurities up to 3 mm in size. Their hydraulic components: impeller, feed screw and pump body in PBT allow them to be used with water, emulsions and oily substances in general, with a viscosity not exceeding 21 cSt (3° Engel). The temperature of the liquid must not exceed 70°C.

They are commonly used on:

- **machine tools** (milling and turning machines-drills)
- **glass processing machinery** (TRI version)
- **printing machines**

They are normally installed on a tank with a capacity which is proportional to their flow rate, about 3-4 cm from the bottom.

It is important to make sure that the maximum liquid level in the tank is always 3-4 cm lower than the support flange (see figure).

Should the liquid be particularly dirty, it is advisable to build a compartment tank in order to allow the sludge to deposit before it is sucked by the pump.

For different uses, please consult our Technical Office.

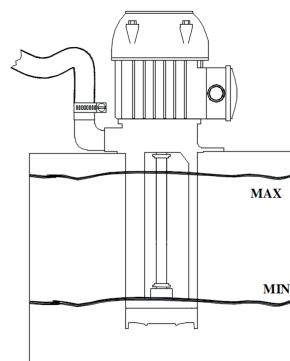
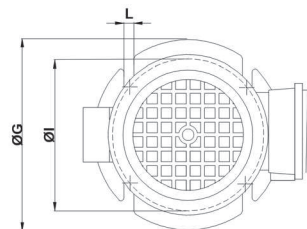
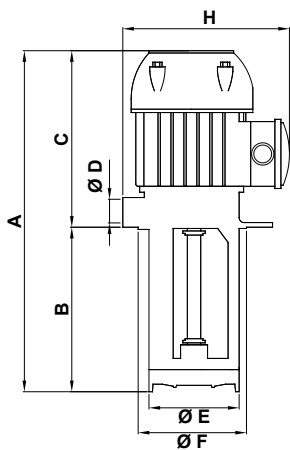

Size and weights table

Type of pump	A mm	B mm	C mm	ØD	ØE mm	ØF mm	ØG mm	H mm	ØI mm	L mm	Mass kg
SPV 12	255	90 T	165	3/4"	98	100	130	151	115	7 (n.4)	2.8
	285	120 T									2.9
	335	170 T									2.9
	385	220 T									3.0
	435	270 T									3.1
	515	350									3.3
SPV 18	255	90 T	165	3/4"	98	100	130	151	115	7 (n.4)	2.8
	285	120 T									2.9
	335	170 T									3.0
	385	220 T									3.1
	435	270 T									3.2
	515	350									3.3

On demand: T= TRI mode

Rating plate data

Type of pump	kW		V 230/400 - Hz 50			Q - maxQ litres/min	maxH - H metres
	Input (P1)	Nom. (P2)	In Amp.	n min ⁻¹	cos φ		
SPV 12	0.15	0.07	0.52/0.30	2770	0.71	6 - 56	4.5 - 0
SPV 18	0.17	0.09	0.55/0.32	2730	0.72	2 - 65	5.5 - 0

Hydraulic performance curves (open impeller)

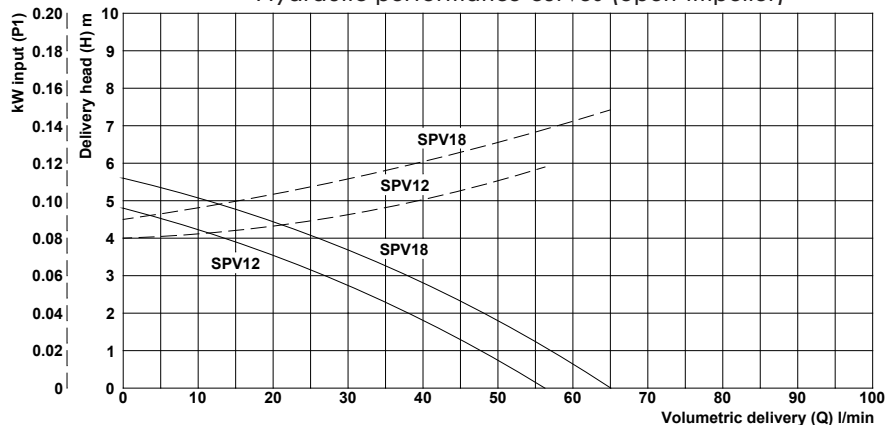

Hydraulic performance table (open impeller)

Type of pump	Volumetric delivery (Q) l/min ↓												
	0	0.5	1	1.5	2	2.5	3	3.5	4	4.5	5	5.5	6
SPV 12	56	52	48	43	38	33	27	21	13	6			
SPV 18	65	61	57	53	48	43	38	32	26	19	12	2	

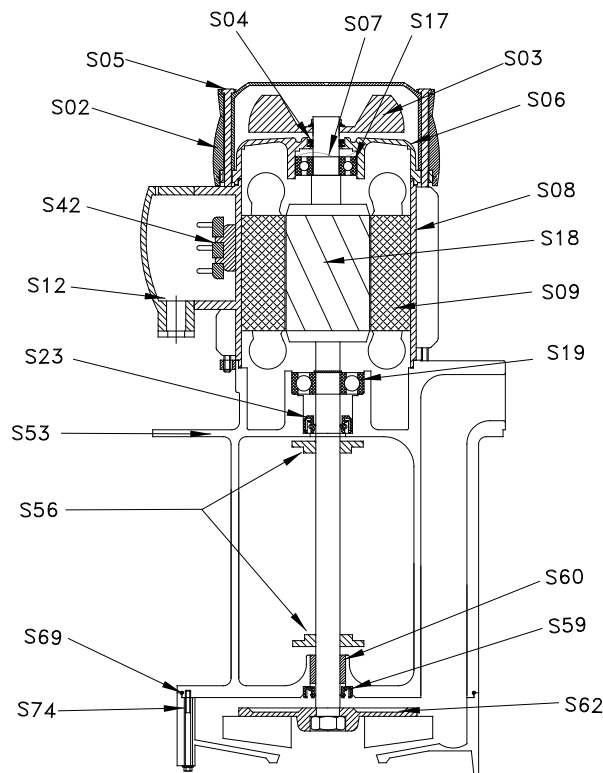

Spare parts nomenclature

Component	
S02.	Fan cover
S03.	Fan
S04.	V-ring
S05.	Stay rod
S06.	Upper shield
S07.	Spring ring
S08.	Housing
S09.	Wound stator
S12.	Terminal box
S17.	Upper bearing
S18.	Axis + rotor
S19.	Lower bearing
S23.	Motor seal ring
S42.	Terminal board
S53.	Pump body
S56.	TRI washer
S59.	Seal
S60.	Bushing
S62.	Impeller
S69.	O-ring
S74.	Impeller-cover

SPV 12	
Materials	
Nylon	
Nylon	
NBR	
Steel	
Aluminium	
Steel	
Aluminium	
-	
Nylon	
-	
Steel*	
-	
NBR	
-	
PBT	
PBT	
NBR**	
Bronze**	
PBT	
NBR	
PBT	

SPV 18	
Materials	
Nylon	
Nylon	
NBR	
Steel	
Aluminium	
Steel	
Aluminium	
-	
Nylon	
-	
Steel*	
-	
NBR	
-	
PBT	
PBT	
NBR**	
Bronze**	
PBT	
NBR	
PBT	

*On demand. Ax. AISI 316

*On demand. Ax. AISI 316

**Available only on suction pipe 220-270-350 **Available only on suction pipe 220-270-350

Submersible motor-driven pumps

Type SPV 25-33



Uses

They are suitable for transferring liquids containing impurities up to 3 mm in size. Their hydraulic components: impeller, feed screw and pump body in PBT allow them to be used with water, emulsions and oily substances in general, with a viscosity not exceeding 21 cSt (3° Engel). The temperature of the liquid must not exceed 70°C.

They are commonly used on:

- machine tools (milling and turning machines-drills)
- glass processing machinery (TRI version)
- printing machines
- air-conditioning systems
- filtration systems

They are normally installed on a tank with a capacity which is proportional to their flow rate, about 3-4 cm from the bottom.

It is important to make sure that the maximum liquid level in the tank is always 3-4 cm lower than the support flange (see figure).

Should the liquid be particularly dirty, it is advisable to build a compartment tank in order to allow the sludge to deposit before it is sucked by the pump.

For different uses, please consult our Technical Office.

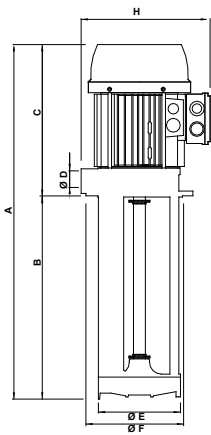

Size and weights table

Type of pump	A mm	B mm	C mm	ØD	ØE mm	ØF mm	ØG mm	H mm	ØI mm	L mm	Mass kg
SPV 25	300	90 T	210	3/4"	98	100	130	170	115	7 (n.4)	4.3
	330	120 T									4.4
	380	170 T									4.5
	430	220 T									4.6
	480	270 T									4.7
SPV 33	560	350	210	3/4"	98	100	130	170	115	7 (n.4)	4.8
	300	90 T									4.8
	330	120 T									4.9
	380	170 T									5.0
	430	220 T									5.1
	480	270 T	5.2								
	560	350	5.3								

On demand: T= TRI mode

Rating plate data

Type of pump	kW		V 230/400 - Hz 50			Q - maxQ litres/min	maxH - H metres
	Input (P1)	Nom. (P2)	In Amp.	n min ⁻¹	cos φ		
SPV 25	0.26	0.18	0.85/0.49	2810	0.76	12 - 72	5.5 - 0
SPV 33	0.36	0.25	1.13/0.65	2800	0.78	7 - 75	6.0 - 0

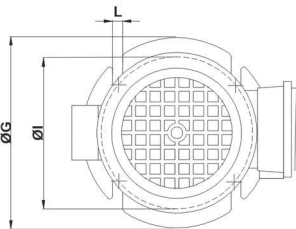

Hydraulic performance curves (open impeller)

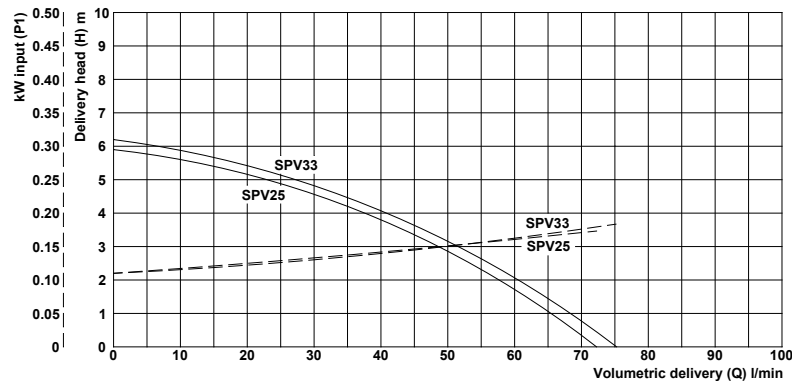

Hydraulic performance table (open impeller)

Delivery head (H) m	0	0.5	1	1.5	2	2.5	3	3.5	4	4.5	5	5.5	6	6.5	7
Type of pump	Volumetric delivery (Q) l/min ↓														
SPV 25	72	68	65	62	57	53	49	43	37	31	23	12			
SPV 33	75	72	68	65	61	56	52	46	41	35	27	18	7		

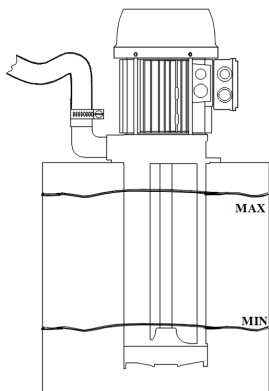

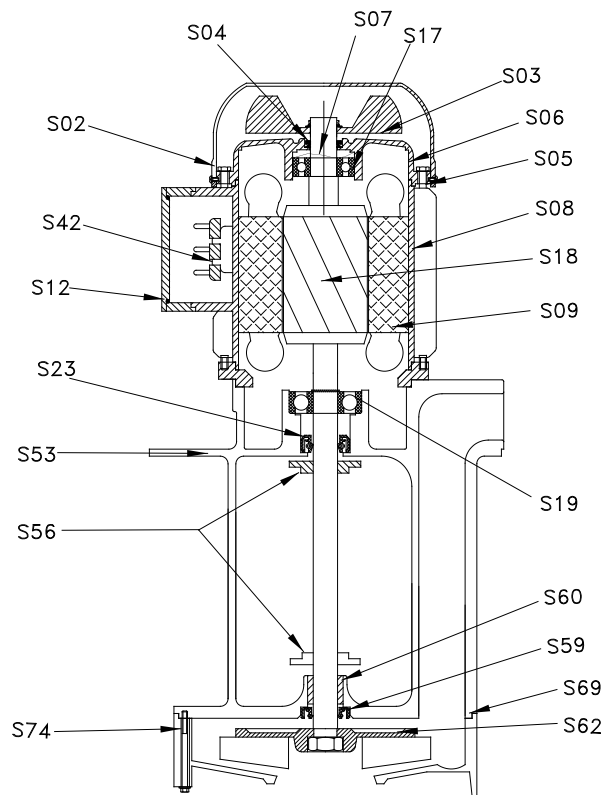

Spare parts nomenclature

Component	
S02.	Fan cover
S03.	Fan
S04.	V-ring
S05.	Stay rod
S06.	Upper shield
S07.	Spring ring
S08.	Housing
S09.	Wound stator
S12.	Terminal box
S17.	Upper bearing
S18.	Axis + rotor
S19.	Lower bearing
S23.	Motor seal ring
S42.	Terminal board
S53.	Pump body
S56.	TRI washer
S59.	Seal
S60.	Bushing
S62.	Impeller
S69.	O-ring
S74.	Impeller-cover

SPV 25	Materials
	Nylon*
	Nylon
	NBR
	Steel
	Aluminium
	Steel
	Aluminium
	-
	Nylon
	-
	Steel**
	-
	NBR
	-
	PBT
	PBT
	NBR***
	Bronze***
	PBT
	NBR
	PBT

SPV 33	Materials
	Nylon*
	Nylon
	NBR
	Steel
	Aluminium
	Steel
	Aluminium
	-
	Nylon
	-
	Steel**
	-
	NBR
	-
	PBT
	PBT
	NBR***
	Bronze***
	PBT
	NBR
	PBT

*On demand Sheet metal

**On demand. Ax. AISI 416

***Available only on suction pipe 350

*On demand Sheet metal

**On demand. Ax. AISI 416

***Available only on suction pipe 350

Submersible motor-driven pumps

Type SPV 50-75



Uses

They are suitable for transferring liquids containing impurities up to 3 mm in size.

Their hydraulic components: impeller, feed screw and pump body in Nylon allow them to be used with water, emulsions and oily substances in general, with a viscosity not exceeding 21 cSt (3° Engle).

The temperature of the liquid must not exceed 70°C.

They are commonly used on:

- **machine tools** (milling and turning machines)
- **glass processing machinery** (TRI version on suction pipes 200 and 270)
- **printing machines**
- **air-conditioning systems**
- **spray booths**

They are normally installed on a tank with a capacity which is proportional to their flow rate, about 3-4 cm from the bottom.

It is important to make sure that the maximum liquid level in the tank is always 3-4 cm lower than the support flange (see figure).

Should the liquid be particularly dirty, it is advisable to build a compartment tank in order to allow the sludge to deposit before it is sucked by the pump.

For different uses, please consult our Technical Office.

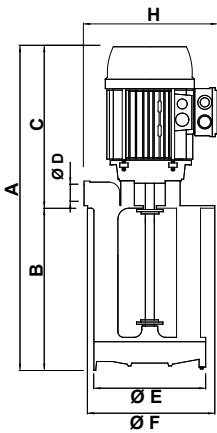

Size and weights table

Type of pump	A mm	B mm	C mm	ØD	ØE mm	ØF mm	ØG mm	H mm	ØI mm	L mm	Mass kg
SPV 50	460	200 T	260	1 ¼"	138	140	180	215	160	7 (n.4)	7.7
	530	270 T									8.3
	610	350									8.9
SPV 75	460	200 T	260	1 ¼"	138	140	180	215	160	7 (n.4)	8.7
	530	270 T									9.2
	610	350									9.9

On demand: T= TRI mode

Rating plate data

Type of pump	kW		V 230/400 - Hz 50			Q - maxQ litres/min	maxH - H metres
	Input (P1)	Nom. (P2)	In Amp.	n min ⁻¹	cos φ		
SPV 50	1.00	0.75	3.24/1.87	2770	0.77	43 - 263	12 - 0
SPV 75	1.20	0.90	3.83/2.21	2760	0.78	75 - 275	12 - 0

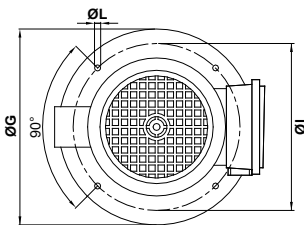

Hydraulic performance curves (open impeller)

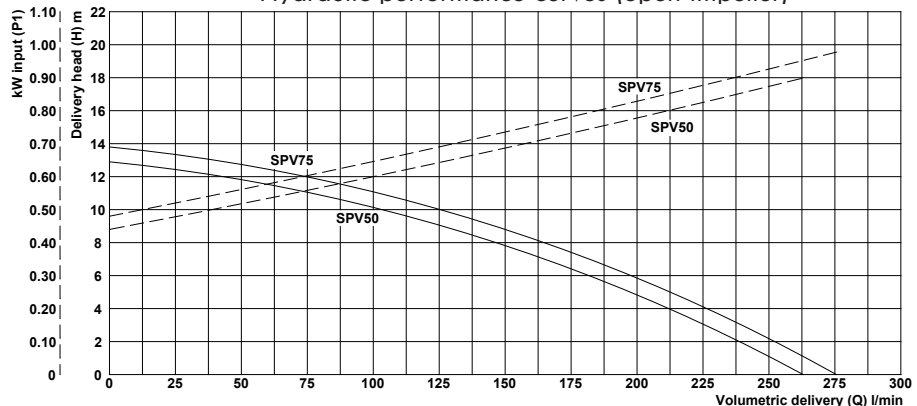

Hydraulic performance table (open impeller)

Type of pump	Volumetric delivery (Q) l/min ↓																
	0	1	2	3	4	5	6	7	8	9	10	12	14	16	18		
SPV 50	263	250	238	226	213	198	182	164	147	127	103	43					
SPV 75	275	264	252	240	226	213	198	182	165	146	125	75					

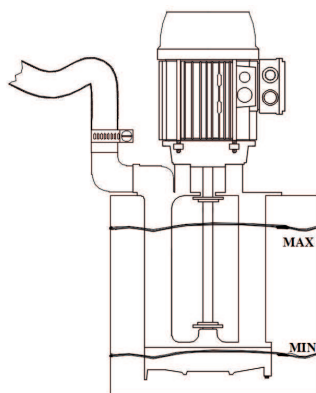

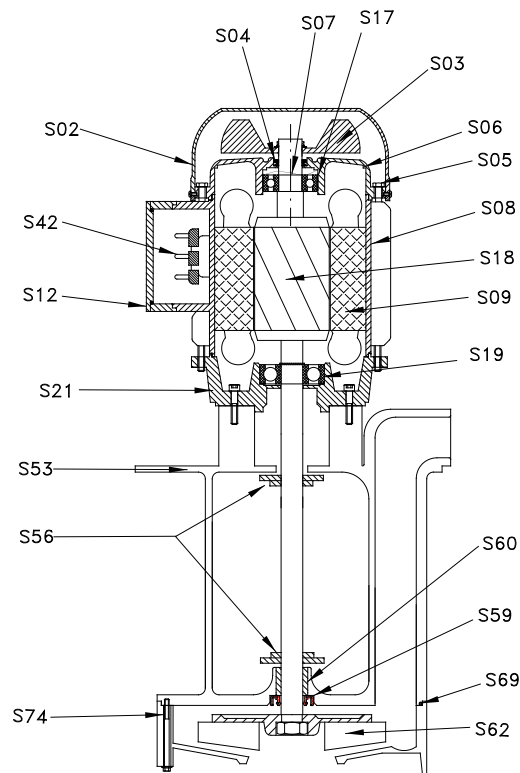

Spare parts nomenclature

Component	
S02.	Fan cover
S03.	Fan
S04.	V-ring
S05.	Stay rod
S06.	Upper shield
S07.	Spring ring
S08.	Housing
S09.	Wound stator
S12.	Terminal box
S17.	Upper bearing
S18.	Axis + rotor
S19.	Lower bearing
S21.	Flange
S23.	Motor seal ring
S42.	Terminal board
S53.	Pump body
S56.	TRI washer
S60.	Bushing
S62.	Impeller
S69.	O-ring
S74.	Impeller-cover

SPV 50	
Materials	
Nylon*	
Nylon	
NBR	
Steel	
Aluminium	
Steel	
Aluminium	
-	
Nylon	
-	
(AX.AISI 416)**	
-	
Aluminium	
NBR	
-	
Nylon	
PBT	
Engineering plastic	
Nylon	
NBR	
Nylon	

SPV 75	
Materials	
Nylon*	
Nylon	
NBR	
Steel	
Aluminium	
Steel	
Aluminium	
-	
Nylon	
-	
(AX.AISI 416)**	
-	
Aluminium	
NBR	
-	
Nylon	
PBT	
Engineering plastic	
Nylon	
NBR	
Nylon	

*On demand Sheet metal

**On demand covered in PBT on suction pipe 200-270-350

*On demand Sheet metal

**On demand covered in PBT on suction pipe 200-270-350

Submersible motor-driven pumps

Type SPV 100-150



Uses

They are suitable for transferring liquids containing impurities up to 3 mm in size. Their hydraulic components: impeller, feed screw and pump body in Nylon allow them to be used with water, emulsions and oily substances in general, with a viscosity not exceeding 21 cSt (3° Engel). The temperature of the liquid must not exceed 70°C.

They are commonly used on:

- **machine tools** (milling and turning machines)
- **glass processing machinery** (TRI version when possible)
- **printing machines**
- **air-conditioning systems**

They are normally installed on a tank with a capacity which is proportional to their flow rate, about 4-5 cm from the bottom.

It is important to make sure that the maximum liquid level in the tank is always 3-4 cm lower than the support flange (see figure).

Should the liquid be particularly dirty, it is advisable to build a compartment tank in order to allow the sludge to deposit before it is sucked by the pump.

For different uses, please consult our Technical Office.

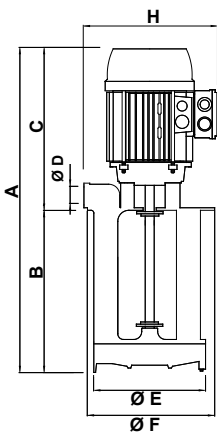

Size and weights table

Type of pump	A mm	B mm	C mm	ØD	ØE mm	ØF mm	ØG mm	H mm	ØI mm	ØL mm	Mass kg
SPV 100	500	200 T	300	1 ¼"	138	140	180	230	160	9 (n.4)	10.5
	570	270 T									11.0
	650	350									11.7
SPV 150	500	200 T	300	1 ¼"	138	140	180	230	160	9 (n.4)	11.8
	570	270 T									12.3
	650	350									13.0

On demand: T= TRI mode

Rating plate data

Type of pump	kW		V 230/400 - Hz 50			Q - maxQ litres/min	maxH - H metres
	Input (P1)	Nom. (P2)	In Amp.	n min ⁻¹	cos φ		
SPV 100	1.01	0.75	3.1/1.8	2800	0.80	15 - 280	14 - 0
SPV 150	1.41	1.1	4.3/2.5	2825	0.81	36 - 300	14 - 0

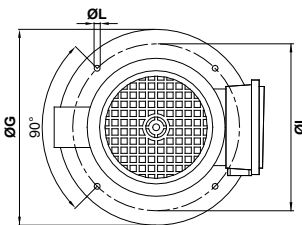

Hydraulic performance curves (open impeller)

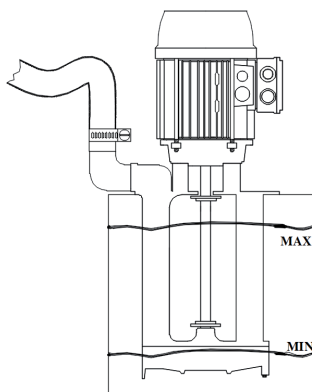
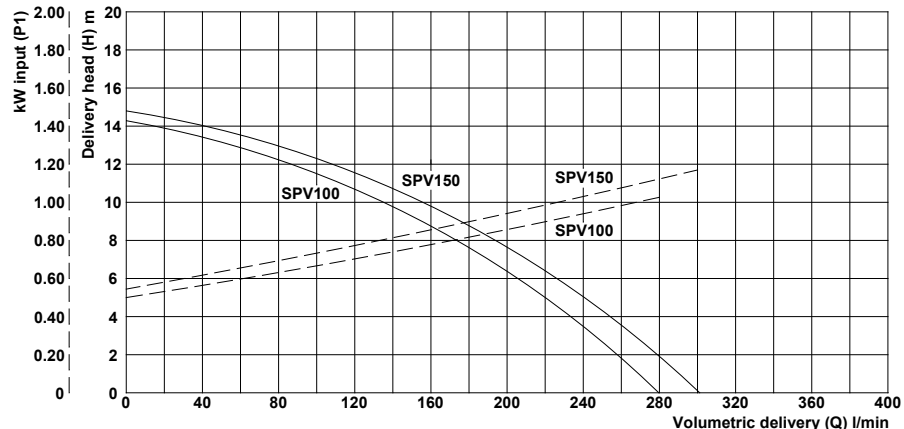

Hydraulic performance table (open impeller)

Type of pump	Volumetric delivery (Q) l/min ↓														
	0	1	2	3	4	5	6	7	8	9	10	12	14	16	18
SPV 100	280	269	258	246	233	220	206	192	176	159	139	89	15		
SPV 150	300	290	279	267	253	238	225	210	195	179	160	112	36		

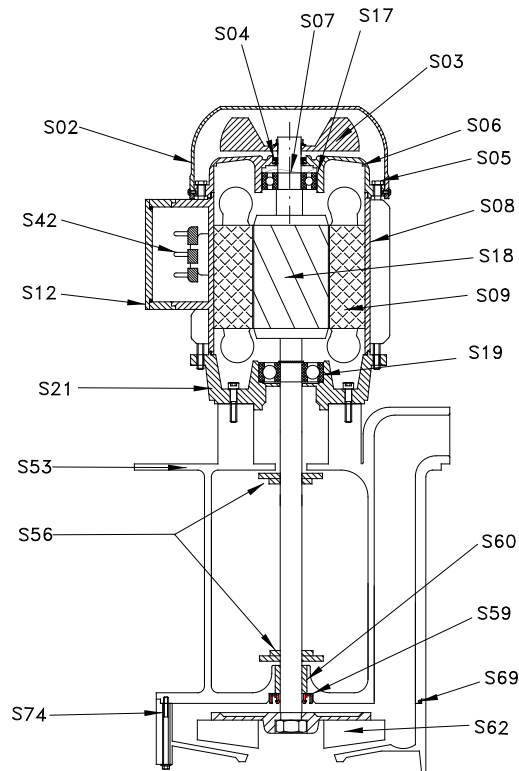

Spare parts nomenclature

	Component
S02.	Fan cover
S03.	Fan
S04.	V-ring
S05.	Stay rod
S06.	Upper shield
S07.	Spring ring
S08.	Housing
S09.	Wound stator
S12.	Terminal box
S17.	Upper bearing
S18.	Axis + rotor
S19.	Lower bearing
S21.	Flange
S23.	Motor seal ring
S42.	Terminal board
S53.	Pump body
S56.	TRI washer
S60.	Bushing
S62.	Impeller
S69.	O-ring
S74.	Impeller-cover

SPV 100	Materials
	Nylon*
	Nylon
	NBR
	Steel
	Aluminium
	Steel
	Aluminium
	-
	Nylon
	-
	(AX.AISI 416)
	-
	Aluminium
	NBR
	-
	Nylon
	PBT
	Bronze
	Nylon
	NBR
	Nylon

SPV 150	Materials
	Nylon*
	Nylon
	NBR
	Steel
	Aluminium
	Steel
	Aluminium
	-
	Nylon
	-
	(AX.AISI 416)
	-
	Aluminium
	NBR
	-
	Nylon
	PBT
	Bronze
	Nylon
	NBR
	Nylon

*On demand Sheet metal

*On demand Sheet metal

Submersible motor-driven pumps

Type SP 12-18



Uses

They are suitable for transferring liquids containing impurities up to 3 mm in size. Their hydraulic components: impeller and feed screw in PBT, pump body in cast iron allow them to be used with water, emulsions and oily substances in general, with a viscosity not exceeding 21 cSt (3° Engel). The temperature of the liquid must not exceed 70°C.

- They are commonly used on:
- machine tools (milling and turning machines)
 - glass processing machinery (TRI version)
 - surface treatment plants
 - filtration systems

They are normally installed on a tank with a capacity which is proportional to their flow rate, about 3-4 cm from the bottom.

It is important to make sure that the maximum liquid level in the tank is always 3-4 cm lower than the support flange (see figure).

Should the liquid be particularly dirty, it is advisable to build a compartment tank in order to allow the sludge to deposit before it is sucked by the pump.

For different uses, please consult our Technical Office.

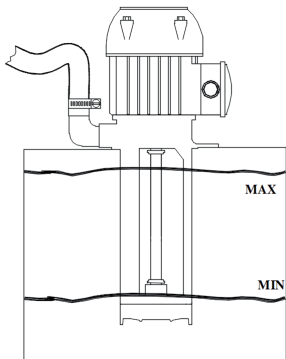
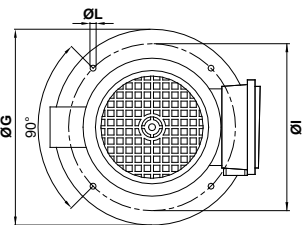
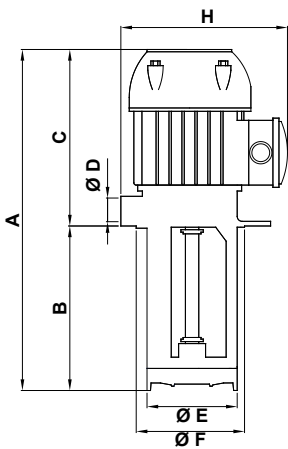

Size and weights table

Type of pump	A mm	B mm	C mm	ØD	ØE mm	ØF mm	ØG mm	H mm	ØI mm	ØL mm	Mass kg
SP 12	265	90 T	165	3/4"	98	100	130	151	115	7 (n.4)	5.0
	285	120 T									5.3
	335	170 T									5.5
	385	220 T									5.7
	435	270 T									6.0
	515	350									6.5
SP 18	265	90 T	165	3/4"	98	100	130	151	115	7 (n.4)	5.1
	285	120 T									5.4
	335	170 T									5.6
	385	220 T									5.7
	435	270 T									6.0
	515	350									6.6

On demand: T= TRI mode

Rating plate data

Type of pump	kW		V 230/400 - Hz 50			Q - maxQ litres/min	maxH - H metres
	Input (P1)	Nom. (P2)	In Amp.	n min ⁻¹	cos φ		
SP 12	0.15	0.07	0.52/0.30	2770	0.71	12 - 65	4.5 - 0
SP 18	0.17	0.09	0.55/0.32	2730	0.72	6 - 75	5.5 - 0

Hydraulic performance curves (open impeller)

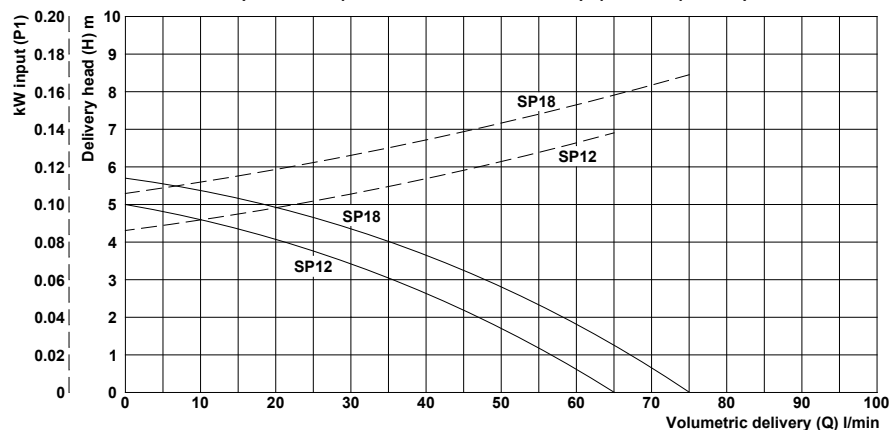

Hydraulic performance table (open impeller)

Type of pump	Volumetric delivery (Q) l/min ↓												
	0	0.5	1	1.5	2	2.5	3	3.5	4	4.5	5	5.5	6
SP 12	65	61	57	52	47	41	35	29	21	12			
SP 18	75	71	67	63	58	53	48	42	35	28	18	6	

Submersible motor-driven pumps

Type SP 12-18

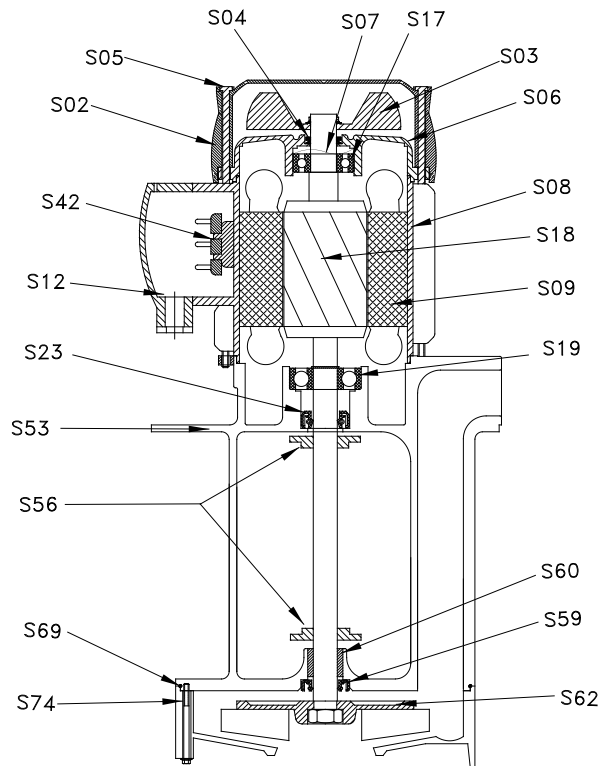

Spare parts nomenclature

	Component
S02.	Fan cover
S03.	Fan
S04.	V-ring
S05.	Stay rod
S06.	Upper shield
S07.	Spring ring
S08.	Housing
S09.	Wound stator
S12.	Terminal box
S17.	Upper bearing
S18.	Axis + rotor
S19.	Lower bearing
S23.	Motor seal ring
S42.	Terminal board
S53.	Pump body
S56.	TRI washer
S59.	Seal
S60.	Bushing
S62.	Impeller
S69.	O-ring
S74.	Impeller-cover

SP 12	Materials
	Nylon
	Nylon
	NBR
	Steel
	Aluminium
	Steel
	Aluminium
	-
	Nylon
	-
	Steel*
	-
	NBR
	-
	Cast Iron G20
	PBT
	NBR***
	Bronze***
	PBT**
	NBR
	PBT**

SP 18	Materials
	Nylon
	Nylon
	NBR
	Steel
	Aluminium
	Steel
	Aluminium
	-
	Nylon
	-
	Steel*
	-
	NBR
	-
	Cast Iron G20
	PBT
	NBR***
	Bronze***
	PBT**
	NBR
	PBT**

*On demand. Ax. AISI 416
 **On demand Cast Iron G20
 *** Available only on suction pipe 350

*On demand. Ax. AISI 416
 **On demand Cast Iron G20
 *** Available only on suction pipe 350

Submersible motor-driven pumps

Type SP 25-33

Uses

They are suitable for transferring liquids containing impurities up to 3 mm in size. Their hydraulic components: impeller and feed screw in PTB, pump body in cast iron allow them to be used with water, emulsions and oily substances in general, with a viscosity not exceeding 21 cSt (3° Engel). The temperature of the liquid must not exceed 70°C.

They are commonly used on:

- **machine tools** (milling and turning machines)
- **glass processing machinery** (TRI version)
- **surface treatment plants**
- **filtration systems**

They are normally installed on a tank with a capacity which is proportional to their flow rate, about 3-4 cm from the bottom.

It is important to make sure that the maximum liquid level in the tank is always 3-4 cm lower than the support flange (see figure).

Should the liquid be particularly dirty, it is advisable to build a compartment tank in order to allow the sludge to deposit before it is sucked by the pump.

For different uses, please consult our Technical Office.

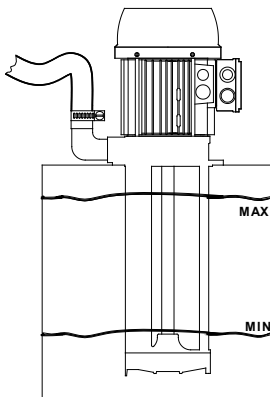
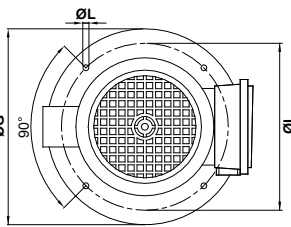
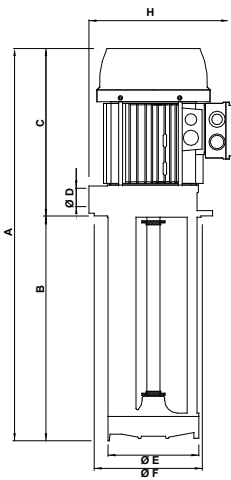

Size and weights table

Type of pump	A mm	B mm	C mm	ØD	ØE mm	ØF mm	ØG mm	H mm	ØI mm	ØL mm	Mass kg
SP 25	305	90 T	215	3/4"	98	100	130	170	115	7 (n.4)	6.5
	335	120 T									6.8
	385	170 T									7.1
	435	220 T									7.2
	485	270 T									7.5
SP 33	565	350	215	3/4"	98	100	130	170	115	7 (n.4)	8.1
	305	90 T									7.1
	335	120 T									7.3
	385	170 T									7.6
	435	220 T									7.7
	485	270 T	8.0								
	565	350									8.6

On demand: T= TRI mode

Rating plate data

Type of pump	kW		V 230/400 - Hz 50			Q - maxQ litres/min	maxH - H metres
	Input (P1)	Nom. (P2)	In Amp.	n min ⁻¹	cos φ		
SP 25	0.26	0.18	0.85/0.49	2810	0.76	5 - 85	6 - 0
SP 33	0.36	0.25	1.13/0.65	2800	0.78	11 - 87	6 - 0

Hydraulic performance curves (open impeller)

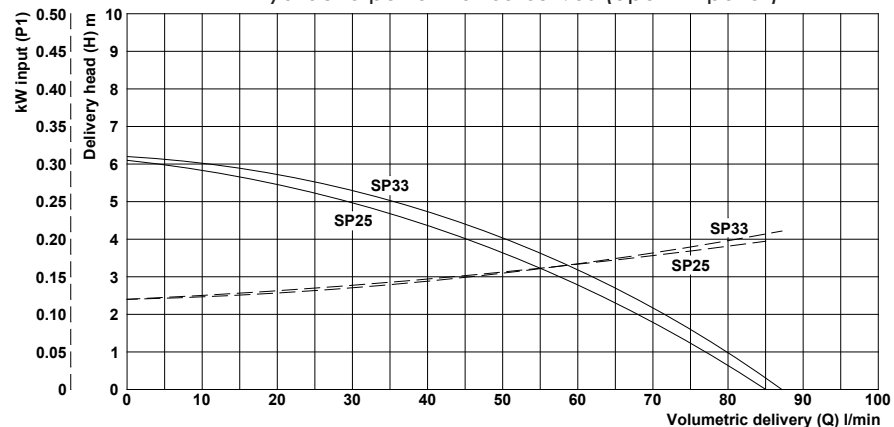

Hydraulic performance table (open impeller)

Type of pump	Volumetric delivery (Q) l/min ↓														
	0	0.5	1	1.5	2	2.5	3	3.5	4	4.5	5	5.5	6	6.5	7
SP 25	85	81	77	72	68	63	58	52	46	38	30	19	5		
SP 33	87	84	80	76	71	67	62	56	50	44	36	26	11		

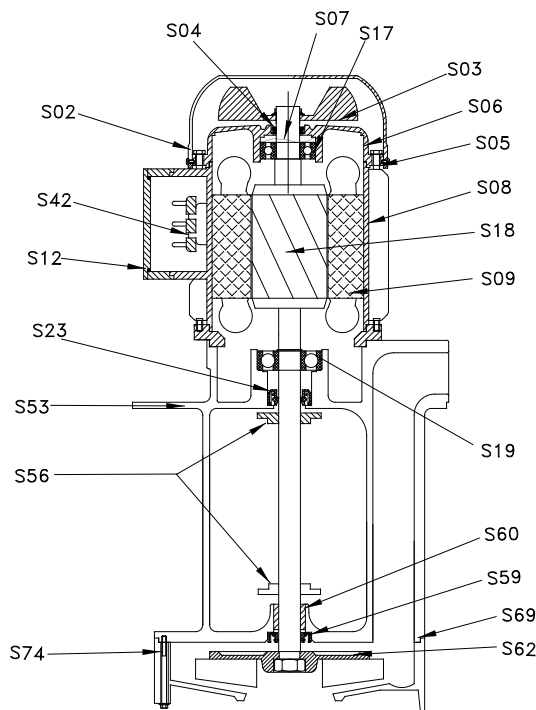

Spare parts nomenclature

Component	
S02.	Fan cover
S03.	Fan
S04.	V-ring
S05.	Stay rod
S06.	Upper shield
S07.	Spring ring
S08.	Housing
S09.	Wound stator
S12.	Terminal box
S17.	Upper bearing
S18.	Axis + Rotor
S19.	Lower bearing
S21.	Flange
S23.	Motor seal ring
S42.	Terminal board
S53.	Pump body
S56.	TRI washer
S59.	Seal
S60.	Bushing
S62.	Impeller
S69.	O-ring
S74.	Impeller-cover

SP 25	Materials
	Nylon*
	Nylon
	NBR
	Steel
	Aluminium
	Steel
	Aluminium
	-
	Nylon
	-
	Steel**
	-
	Aluminium
	NBR
	-
	Cast Iron G20
	PBT
	NBR****
	Bronze****
	PBT***
	NBR
	PBT***

SP 33	Materials
	Nylon*
	Nylon
	NBR
	Steel
	Aluminium
	Steel
	Aluminium
	-
	Nylon
	-
	Steel**
	-
	Aluminium
	NBR
	-
	Cast Iron G20
	PBT
	NBR****
	Bronze****
	PBT***
	NBR
	PBT***

*On demand Sheet metal
 **On demand. Ax. AISI 416
 ***On demand Cast Iron G20
 **** Available only on suction pipe 350

*On demand Sheet metal
 **On demand. Ax. AISI 416
 ***On demand Cast Iron G20
 **** Available only on suction pipe 350

Submersible motor-driven pumps

Type SP 50-75



Uses

They are suitable for transferring liquids containing impurities up to 3 mm in size.

Their hydraulic components: impeller and feed screw in PTB, pump body in cast iron allow them to be used with water, emulsions and oily substances in general, with a viscosity not exceeding 21 cSt (3° Engel).

The temperature of the liquid must not exceed 70°C.

They are commonly used on:

- **machine tools** (milling and turning machines)
- **glass processing machinery** (TRI version)
- **surface treatment plants**
- **filtration systems**

They are normally installed on a tank with a capacity which is proportional to their flow rate, about 4-5 cm from the bottom.

It is important to make sure that the maximum liquid level in the tank is always 3-4 cm lower than the support flange (see figure).

Should the liquid be particularly dirty, it is advisable to build a compartment tank in order to allow the sludge to deposit before it is sucked by the pump.

For different uses, please consult our Technical Office.

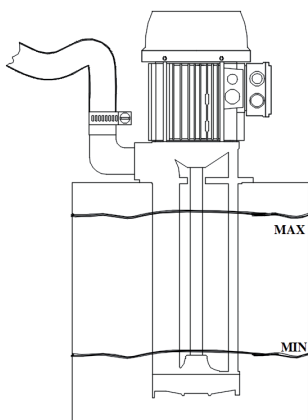
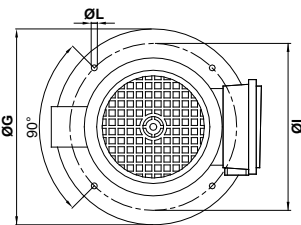
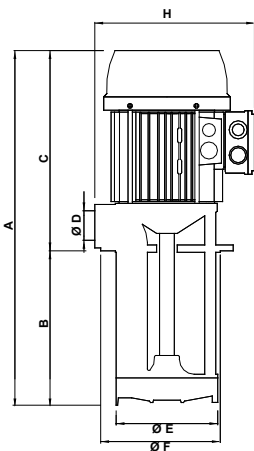

Size and weights table

Type of pump	A mm	B mm	C mm	ØD	ØE mm	ØF mm	ØG mm	H mm	ØI mm	ØL mm	Mass kg
SP 50	450	200 T	250	1 1/4"	138	140	180	215	160	9 (n.4)	13.5
	520	270 T									14.2
	600	350									15.0
	690	440									15.9
	800	550									17.0
SP 75	450	200 T	250	1 1/4"	138	140	180	215	160	9 (n.4)	14.5
	520	270 T									15.2
	600	350									16.0
	690	440									16.9
	800	550									18.0

On demand: T= TRI mode

Rating plate data

Type of pump	kW		V 230/400 - Hz 50			Q - maxQ litres/min	maxH - H metres
	Input (P1)	Nom. (P2)	In Amp.	n min ⁻¹	cos φ		
SP 50	1.00	0.75	3.24/1.87	2770	0.77	70 - 288	10 - 0
SP 75	1.20	0.90	3.83/2.21	2760	0.78	55 - 320	12 - 0

Hydraulic performance curves (open impeller)

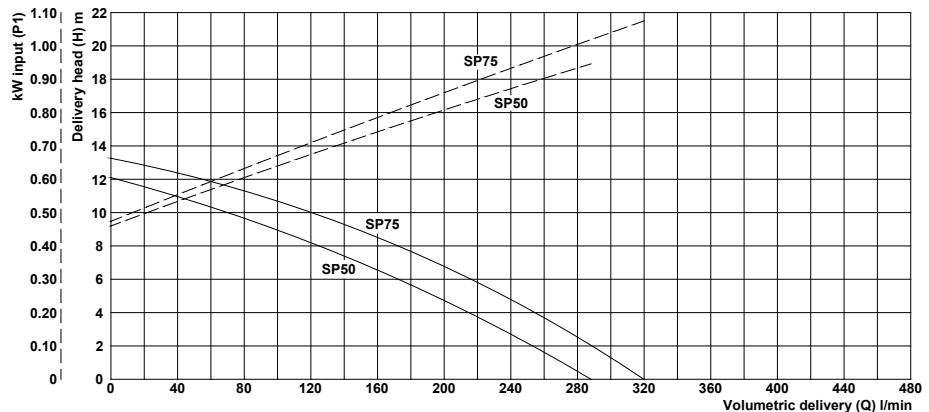

Hydraulic performance table (open impeller)

Type of pump	Volumetric delivery (Q) l/min ↓																	
	0	1	2	3	4	5	6	7	8	9	10	12	14	16	18			
SP 50	288	271	251	234	215	194	172	150	125	100	70							
SP 75	320	304	289	272	254	236	216	195	172	147	120	55						

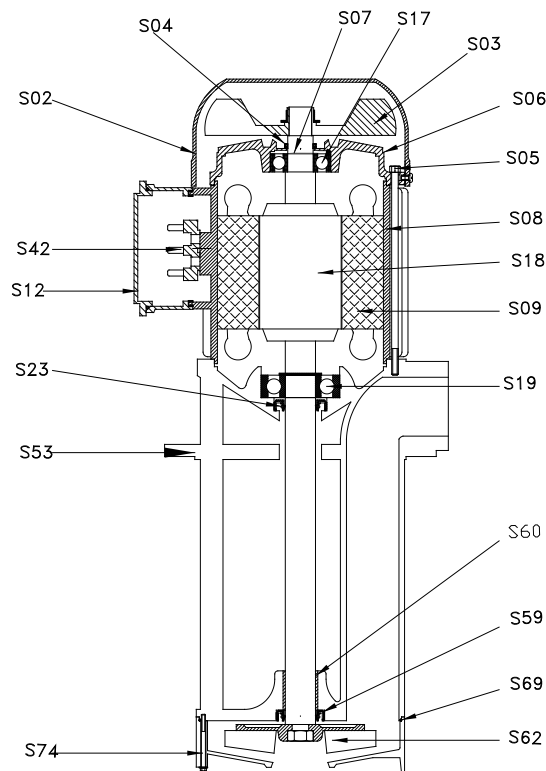

Spare parts nomenclature

	Component
S02.	Fan cover
S03.	Fan
S04.	V-ring
S05.	Stay rod
S06.	Upper shield
S07.	Spring ring
S08.	Housing
S09.	Wound stator
S12.	Terminal box
S17.	Upper bearing
S18.	Axis + Rotor
S19.	Lower bearing
S23.	Motor seal ring
S42.	Terminal board
S53.	Pump body
S59.	Seal
S60.	Bushing
S62.	Impeller
S69.	O-ring
S74.	Impeller-cover

SP 50	Materials
	Nylon*
	Nylon
	NBR
	Steel
	Aluminium
	Steel
	Aluminium
	-
	Nylon
	-
	Steel**
	-
	NBR
	-
	Cast Iron G20
	NBR
	Bronze
	PBT***
	NBR
	PBT***

SP 75	Materials
	Nylon*
	Nylon
	NBR
	Steel
	Aluminium
	Steel
	Aluminium
	-
	Nylon
	-
	Steel**
	-
	NBR
	-
	Cast Iron G20
	NBR
	Bronze
	PBT***
	NBR
	PBT***

*On demand Sheet metal

**On demand. Ax. AISI 416

***On demand Cast Iron G20

*On demand Sheet metal

**On demand. Ax. AISI 416

***On demand Cast Iron G20

Submersible motor-driven pumps

Type SP 100-150



Uses

They are suitable for transferring liquids containing impurities up to 3 mm in size.

Their hydraulic components: impeller and feed screw in PTB, pump body in cast iron allow them to be used with water, emulsions and oily substances in general, with a viscosity not exceeding 21 cSt (3° Engel).

The temperature of the liquid must not exceed 70°C.

They are commonly used on:

- **machine tools** (milling and turning machines)
- **glass processing machinery** (TRI version)
- **surface treatment plants**
- **filtration systems**

They are normally installed on a tank with a capacity which is proportional to their flow rate, about 4-5 cm from the bottom.

It is important to make sure that the maximum liquid level in the tank is always 3-4 cm lower than the support flange (see figure).

Should the liquid be particularly dirty, it is advisable to build a compartment tank in order to allow the sludge to deposit before it is sucked by the pump.

For different uses, please consult our Technical Office.

Size and weights table

Type of pump	A mm	B mm	C mm	ØD	ØE mm	ØF mm	ØG mm	H mm	ØI mm	ØL mm	Mass kg
SP 100	500	200 T	300	1 1/4"	138	140	180	230	160	9 (n.4)	16.3
	570	270 T									17.1
	650	350									18.1
	740	440									19.1
	850	550									20.3
SP 150	500	200 T	300	1 1/4"	138	140	180	230	160	9 (n.4)	17.6
	570	270 T									18.4
	650	350									19.3
	740	440									20.1
	850	550									21.9

On demand: T= TRI mode

Rating plate data

Type of pump	kW		V 230/400 - Hz 50			Q - maxQ litres/min	maxH - H metres
	Input (P1)	Nom. (P2)	In Amp.	n min ⁻¹	cos φ		
SP 100	1.41	1.1	4.3/2.5	2825	0.81	40 - 340	13 - 0
SP 150	1.86	1.5	5.7/3.3	2845	0.83	18 - 400	13 - 0

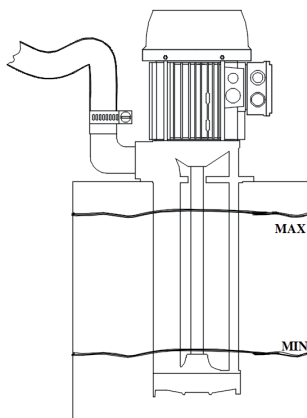
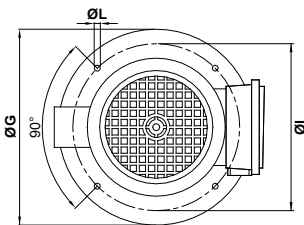
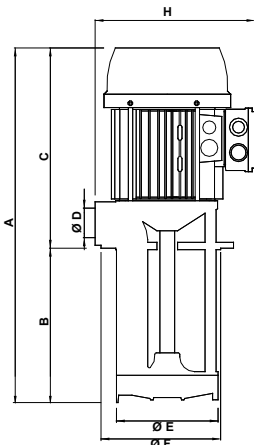

Hydraulic performance curves (open impeller)

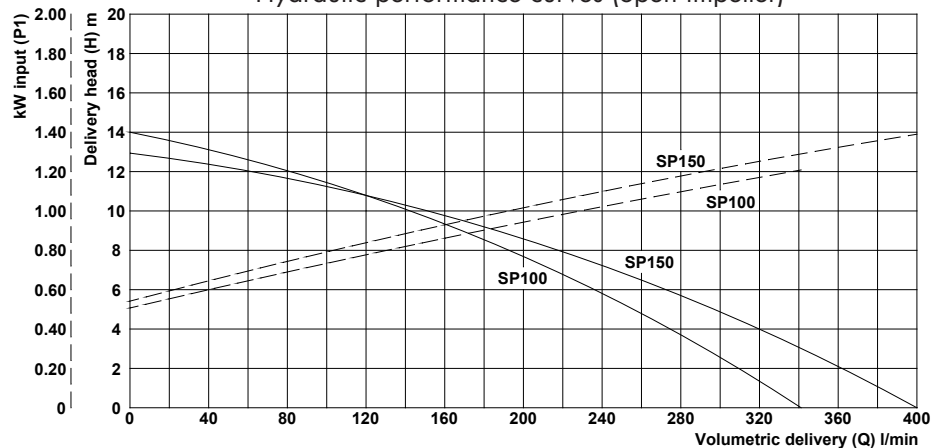

Hydraulic performance table (open impeller)

Delivery head (H) m	0	1	2	3	4	5	6	7	8	9	10	11	12	13	14
Type of pump	Volumetric delivery (Q) l/min ↓														
SP 100	340	326	310	292	275	255	236	216	195	171	144	114	79	40	
SP 150	400	380	358	337	317	296	273	246	219	188	148	107	62	18	

Submersible motor-driven pumps

Type SP 100-150

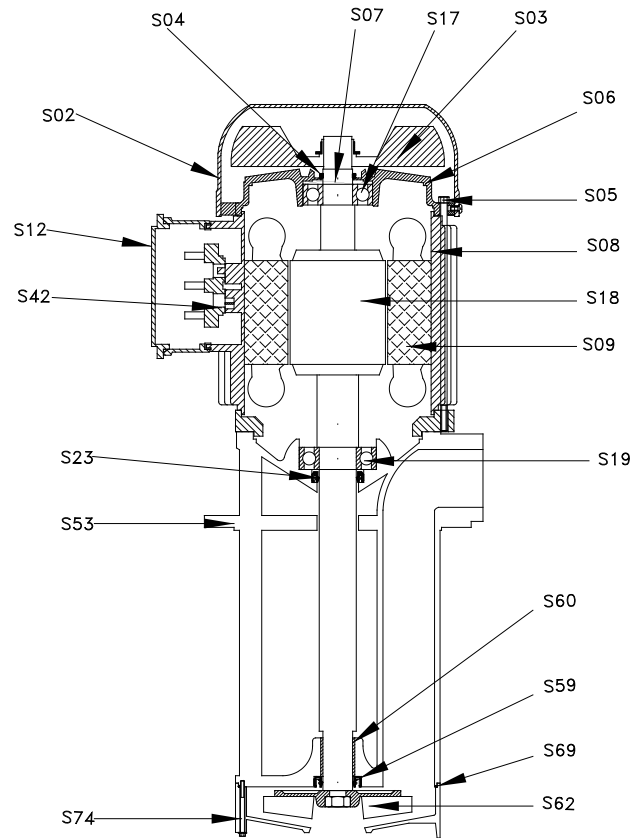

Spare parts nomenclature

Component	
S02.	Fan cover
S03.	Fan
S04.	V-ring
S05.	Stay rod
S06.	Upper shield
S07.	Spring ring
S08.	Housing
S09.	Wound stator
S12.	Terminal box
S17.	Upper bearing
S18.	Axis + Rotor
S19.	Lower bearing
S23.	Motor seal ring
S42.	Terminal board
S53.	Pump body
S59.	Seal
S60.	Bushing
S62.	Impeller
S69.	O-ring
S74.	Impeller-cover

SP 100	Materials
	Nylon*
	Nylon
	NBR
	Steel
	Aluminium
	Steel
	Aluminium
	-
	Nylon
	-
	Steel**
	-
	NBR
	-
	Cast Iron G20
	NBR
	Bronze
	PBT***
	NBR
	PBT***

SP 150	Materials
	Nylon*
	Nylon
	NBR
	Steel
	Aluminium
	Steel
	Aluminium
	-
	Nylon
	-
	Steel**
	-
	NBR
	-
	Cast Iron G20
	NBR
	Bronze
	PBT***
	NBR
	PBT***

*On demand Sheet metal

**On demand. Ax. AISI 416

***On demand Cast Iron G20

*On demand Sheet metal

**On demand. Ax. AISI 416

***On demand Cast Iron G20

Electro pumps for decanting - lateral assembly

Type SQ



Uses

They are suitable for transferring liquids containing impurities up to 3 mm in size. Their hydraulic components: impeller in nylon and feed screw in cast-iron allow them to be used with water, emulsions and oily substances in general, with a viscosity not exceeding 21 cSt (3° Engel). The temperature of the liquid must not exceed 70°C.

They are commonly used on:

- **machine tools** (milling and turning machines)
- **surface treatment plants** (oil separators)

They must be installed laterally on the tank to allow the liquid to enter directly into the suction point (see figure). Should the liquid be particularly dirty, it is advisable to build a compartment tank in order to allow the sludge to deposit before it is sucked by the pump.

For different uses, please consult our Technical Office.

Size and weights table

Type of pump	A mm	B mm	C mm	D mm	E mm	F mm	G mm	ØH mm	ØI	L mm	Mass kg
SQ 56/S	265	170	60	95	140	75	45	7	3/8"	51	3.9
SQ 63/S	300	180	60	95	158	75	45	7	1/2"	51	4.9
SQ 71A	330	245	60	145	175	115	60	9	1"	62	14.5
SQ 71B	330	245	80	145	175	115	60	9	1"	62	15.2
SQ 80A	335	250	80	145	210	115	60	9	1 1/4"	62	16.3
SQ 80B	335	250	80	145	210	115	60	9	1 1/4"	62	17.3

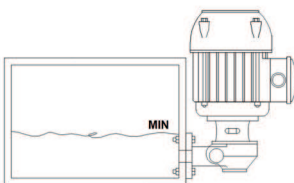
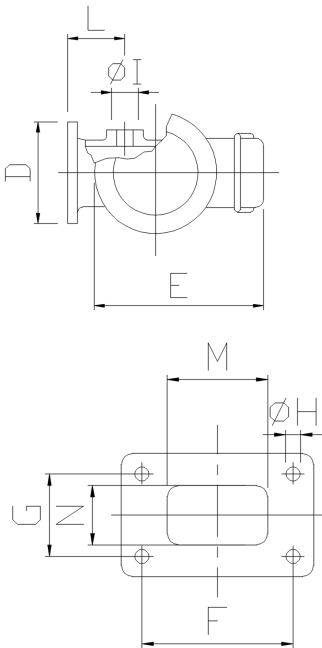
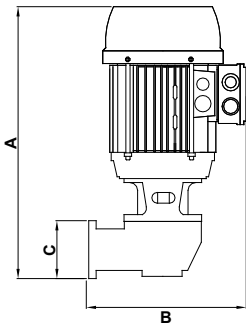

Rating plate data

Type of pump	kW		V 230/400 - Hz 50			Q - maxQ litres/min	maxH - H metres
	Input (P1)	Nom. (P2)	In Amp.	n min ⁻¹	cos φ		
SQ 56/S	0.17	0.09	0.55/0.32	2730	0.72	11 - 60	4 - 0
SQ 63/S	0.26	0.18	0.85/0.49	2810	0.76	27 - 80	4 - 0
SQ 71A	1.00	0.75	3.24/1.87	2770	0.77	52 - 260	10 - 0
SQ 71B	1.20	0.90	3.83/2.21	2760	0.78	98 - 300	10 - 0
SQ 80A	1.41	1.1	4.3/2.5	2825	0.81	72 - 340	12 - 0
SQ 80B	1.41	1.1	4.3/2.5	2825	0.81	62 - 380	14 - 0

Hydraulic performance curves (open impeller)

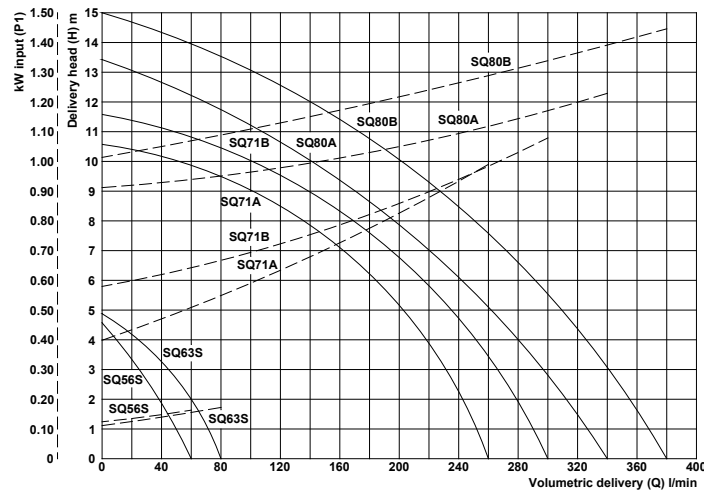

Hydraulic performance table (open impeller)

Type of pump	Delivery head (H) m →																
	0	1	2	3	4	5	6	7	8	9	10	12	14	16	18		
SQ 56/S	60	48	35	27	11												
SQ 63/S	80	69	54	41	27												
SQ 71A	260	251	241	229	218	207	185	158	134	99	52						
SQ 71B	300	289	277	264	251	235	213	190	167	141	98						
SQ 80A	340	326	310	293	274	255	238	218	195	171	130	72					
SQ 80B	380	368	354	340	326	307	293	274	257	222	208	143	62				

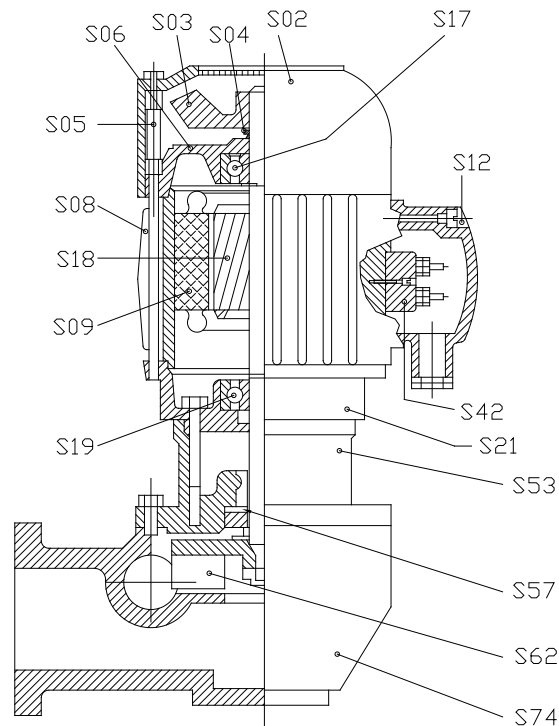

Spare parts nomenclature

		SQ 56	SQ 63	SQ 71A-B	SQ 80A-B
Component		Materials	Materials	Materials	Materials
S02.	Fan cover	Nylon*	Nylon*	Nylon*	Nylon*
S03.	Fan	Nylon	Nylon	Nylon	Nylon
S04.	V-ring	NBR	NBR	NBR	NBR
S05.	Stay rod	Steel	Steel	Steel	Steel
S06.	Upper shield	Aluminium	Aluminium	Aluminium	Aluminium
S07.	Spring ring	Steel	Steel	Steel	Steel
S08.	Housing	Aluminium	Aluminium	Aluminium	Aluminium
S09.	Wound stator	-	-	-	-
S12.	Terminal box	Nylon	Nylon	Nylon	Nylon
S17.	Upper bearing	-	-	-	-
S18.	Axis + Rotor	Steel**	Steel**	Steel**	Steel**
S19.	Lower bearing	-	-	-	-
S21.	Flange	Aluminium	Aluminium	Aluminium	Aluminium
S42.	Terminal board	-	-	-	-
S53.	Cone	PBT***	PBT***	Not available	Not available
S56.	TRI washer	PBT	PBT	PBT	PBT
S57.	Mechanical seal	-	-	-	-
S59.	Seal	NBR	NBR	NBR	NBR
S62.	Impeller	Nylon***	Nylon***	Brass 58***	Brass 58***
S69.	O-ring	NBR	NBR	Not available	Not available
S71.	Adaptor coupling	Not available!	Not available!	Cast Iron G20	Cast Iron G20
S74.	Impeller-cover	Cast Iron G20	Cast Iron G20	Cast Iron G20	Cast Iron G20

*On demand Sheet metal

*On demand Sheet metal

*On demand Sheet metal

*On demand Sheet metal

**On demand.Ax.AISI 316

**On demand.Ax.AISI 416

**On demand.Ax.AISI 416

**On demand.Ax.AISI 416

***On demand Cast Iron G20 ***On demand Cast Iron G20 ***On demand Cast Iron G20 ***On demand Cast Iron G20

Suction electro pumps

Type AU



Uses

They are suitable for transferring clean liquids containing impurities up to 0.03 mm in size. Their hydraulic components: impeller in brass, bottom in cast iron and pump body in aluminium allow them to be used with emulsions, oily substances and liquids in general provided they are not oxidative for the construction materials.

Viscosity must not exceed 21 cST (3° Engel).

They must be installed on the top of the tank and be primed before use.

Should the pump suck air due to a lack of liquid, the priming operation must be repeated.

To ensure proper life to the pump, do not let it run dry, as the mechanical seal is not lubricated.

It is advisable, where possible, to install a suction filter.

For different uses, please consult our Technical Office.

Size and weights table

Type of pump	A mm	ØB mm	C mm	D mm	ØE	ØF mm	ØG mm	Mass kg
AU 56	215	115	48	144	3/8"	95	7	4.3
AU 63	270	115	48	165	1/2"	95	7	5.0

Rating plate data

Type of pump	kW		V 230/400 - Hz 50			Q - maxQ litres/min	maxH - H metres
	Input (P1)	Nom. (P2)	In Amp.	n min ⁻¹	cos φ		
AU 56	0.17	0.09	0.55/0.32	2730	0.72	1 - 7	6 - 0
AU 63	0.26	0.18	0.85/0.49	2810	0.76	2 - 13	10 - 0

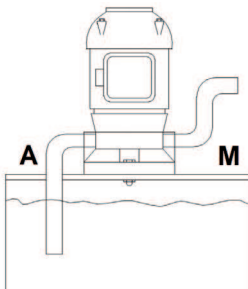
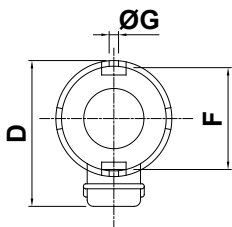
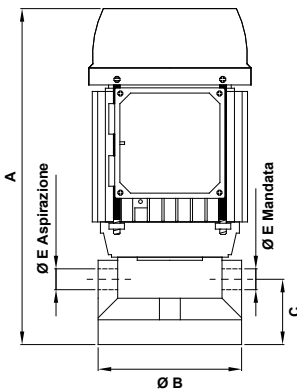

Hydraulic performance curves (peripheral impeller)

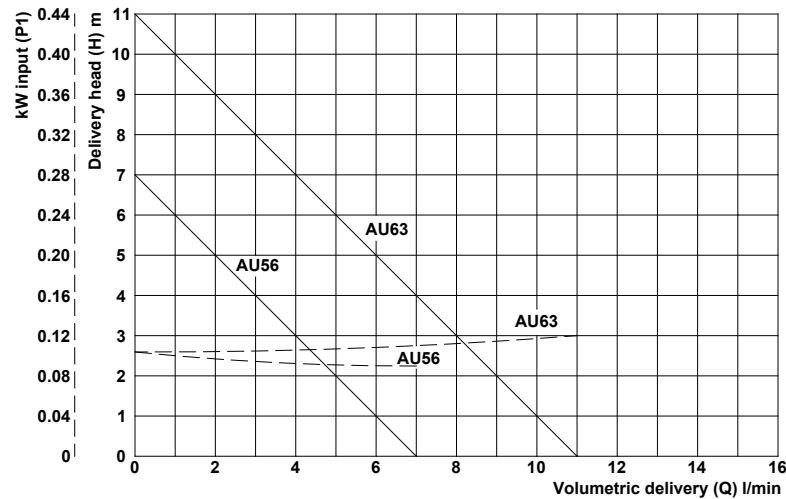

Hydraulic performance table (peripheral impeller)

Delivery head (H) m	0	1	2	3	4	5	6	7	8	9	10	12	14	16	18
→															
Type of pump	Volumetric delivery (Q) l/min ↓														
AU 56	7	6	5	4	3	2	1								
AU 63	11	10	9	8	7	6	5	4	3	2	1				

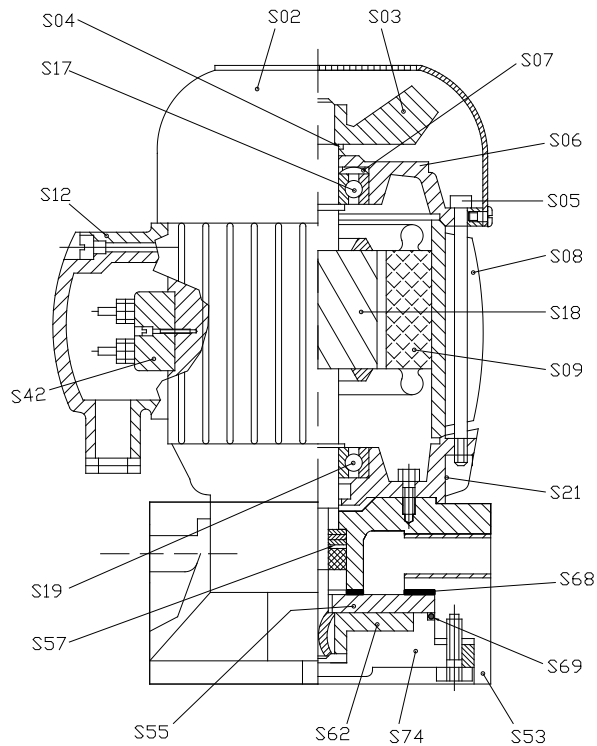

Spare parts nomenclature

Component	
S02.	Fan cover
S03.	Fan
S04.	V-ring
S05.	Stay rod
S06.	Upper shield
S07.	Spring ring
S08.	Housing
S09.	Wound stator
S12.	Terminal box
S17.	Upper bearing
S18.	Axis + Rotor
S19.	Lower bearing
S21.	Flange
S42.	Terminal board
S53.	Pump body
S55.	Diffuser
S57.	Mechanical seal
S62.	Impeller
S68.	Gasket
S69.	O-ring
S74.	Impeller-cover

AU 56	
Materials	
	Nylon
	Nylon
	NBR
	Steel
	Aluminium
	Steel
	Aluminium
	-
	Nylon
	-
	Steel
	-
	Aluminium
	-
	Aluminium
	Cast Iron G20
	NBR
	Brass 58
	Guarnital
	Viton
	Cast Iron G20

AU 63	
Materials	
	Nylon
	Nylon
	NBR
	Steel
	Aluminium
	Steel
	Aluminium
	-
	Nylon
	-
	Steel
	-
	Aluminium
	-
	Aluminium
	Cast Iron G20
	NBR
	Brass 58
	Guarnital
	Viton
	Cast Iron G20

Electro pumps for decanting

Type TR



Uses

They are suitable for transferring liquids containing impurities up to 3 mm in size. Their hydraulic components: impeller in brass and feed screw in cast-iron allow them to be used with water, emulsions and oily substances in general, with a viscosity not exceeding 21 cSt (3° Engel). The temperature of the liquid must not exceed 90°C.

They are normally used when there is no space on the top of the tank.

They must be installed laterally on the tank to allow the liquid to enter directly into the suction point (see figure). Should the liquid be particularly dirty, it is advisable to build a compartment tank in order to allow the sludge to deposit before it is sucked by the pump.

To ensure proper life to the pump, do not let it run dry, as the mechanical seal is not lubricated.

For different uses, please consult our Technical Office.

Size and weights table

Type of pump	A mm	B mm	C mm	ØD	E mm	F mm	Mass kg
TR 71A	320	290	130	1"	40	220	12.1
TR 71B	320	290	130	1"	40	220	13.0
TR 80A	370	290	130	1"	40	220	13.9
TR 80B	370	290	130	1"	40	220	14.7

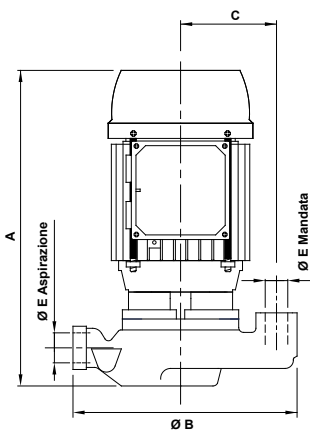

Rating plate data

Type of pump	kW		V 230/400 - Hz 50			Q - maxQ litres/min	maxH - H metres
	Input (P1)	Nom. (P2)	In Amp.	n min ⁻¹	cos φ		
TR 71A	1.00	0.75	3.24/1.87	2770	0.77	55 - 190	10 - 0
TR 71B	1.20	0.90	3.83/2.21	2760	0.78	41 - 200	12 - 0
TR 80A	1.01	0.75	3.1/1.8	2800	0.80	55 - 230	12 - 0
TR 80B	1.41	1.1	4.3/2.5	2825	0.81	45 - 250	14 - 0

Hydraulic performance curves (open impeller)

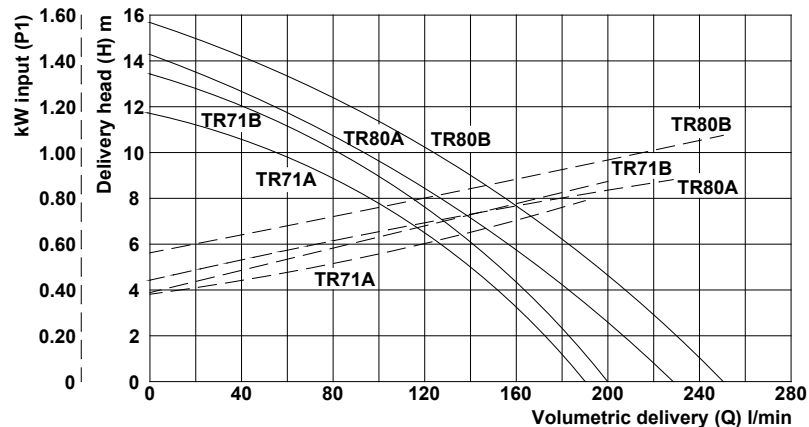

Hydraulic performance table (open impeller)

Type of pump	Volumetric delivery (Q) l/min ↓														
	0	1	2	3	4	5	6	7	8	9	10	12	14	16	18
TR 71A	190	182	172	162	152	140	127	113	96	78	55				
TR 71B	200	192	183	174	164	153	141	128	115	100	82	41			
TR 80A	230	218	207	195	183	170	156	142	127	111	94	55			
TR 80B	250	240	230	220	208	196	183	169	155	140	124	88	45		

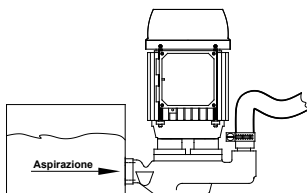

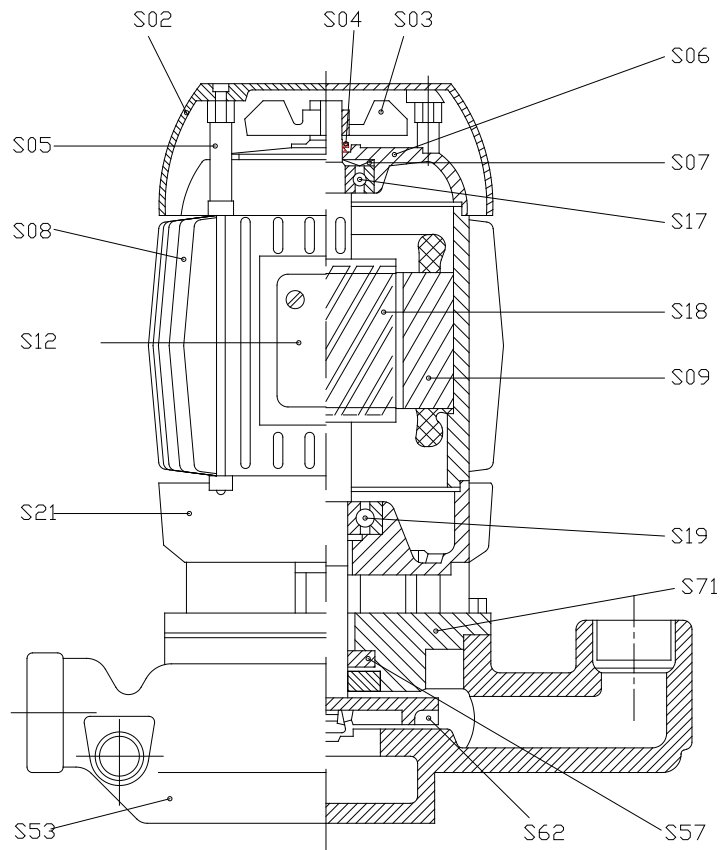

Spare parts nomenclature

Component		TR 71A	TR 71B	TR 80A	TR 80B
		Materials	Materials	Materials	Materials
S02.	Fan cover	Nylon*	Nylon*	Nylon*	Nylon*
S03.	Fan	Nylon	Nylon	Nylon	Nylon
S04.	V-ring	NBR	NBR	NBR	NBR
S05.	Stay rod	Steel	Steel	Steel	Steel
S06.	Upper shield	Aluminium	Aluminium	Aluminium	Aluminium
S07.	Spring ring	Steel	Steel	Steel	Steel
S08.	Housing	Aluminium	Aluminium	Aluminium	Aluminium
S09.	Wound stator	-	-	-	-
S12.	Terminal box	Nylon	Nylon	Nylon	Nylon
S17.	Upper bearing	-	-	-	-
S18.	Axis + Rotor	Steel**	Steel**	Steel**	Steel**
S19.	Lower bearing	-	-	-	-
S21.	Flange	Aluminium	Aluminium	Aluminium	Aluminium
S42.	Terminal board	-	-	-	-
S53.	Pump body	Cast Iron G20	Cast Iron G20	Cast Iron G20	Cast Iron G20
S57.	Mechanical seal	Viton	Viton	Viton	Viton
S62.	Impeller	Brass 58	Brass 58	Brass 58	Brass 58
S71.	Adaptor coupling	Cast Iron G20	Cast Iron G20	Cast Iron G20	Cast Iron G20

*On demand Sheet metal *On demand Sheet metal *On demand Sheet metal *On demand Sheet metal

**On demand.Ax.AISI 416 **On demand.Ax.AISI 416 **On demand.Ax.AISI 416 **On demand.Ax.AISI 416

Submersible motor-driven pumps Type AP 80-90 closed impeller



Uses

They are suitable for transferring liquids containing impurities up to 2 mm in size. Their hydraulic components: impeller and feed screw in cast iron, pump body in cast iron/steel allow them to be used with water, emulsions and oily substances in general, with a viscosity not exceeding 21 cSt (3° Engel). The temperature of the liquid must not exceed 90°C.

They are commonly used on:

- **machine tools** (milling and turning machines-machining centres)
- **glass processing machinery**
- **surface treatment plants**
- **filtration systems**

They are normally installed on a tank with a capacity which is proportional to their flow rate, about 6-7 cm from the bottom.

It is important to make sure that the maximum liquid level in the tank is always 3-4 cm lower than the support flange (see figure).

Should the liquid be particularly dirty, it is advisable to build a compartment tank in order to allow the sludge to deposit before it is sucked by the pump.

For different uses, please consult our Technical Office.

Size and weights table

Type of pump	A mm	B mm	C mm	D mm	ØE mm	ØF mm	ØG mm	ØH mm	ØI mm	ØL mm	M mm	N mm	Mass kg
AP 80B	620	320	300	280	240	1 1/2"	2 1/2"	300	270	13 (n.4)	170	136	37.0
	750	450											43.0
	910	610											46.0
	1160	860											48.0
AP 90A	675	320	355	280	240	1 1/2"	2 1/2"	300	270	13 (n.4)	170	136	41.0
	805	450											47.0
	965	610											49.0
	1215	860											51.0
AP 90B	675	320	355	280	240	1 1/2"	2 1/2"	300	270	13 (n.4)	170	136	43.0
	805	450											49.0
	965	610											51.0
	1215	860											53.0

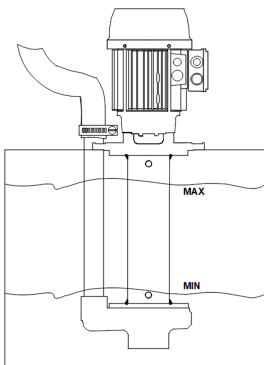
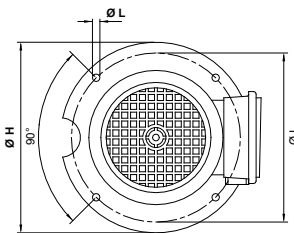
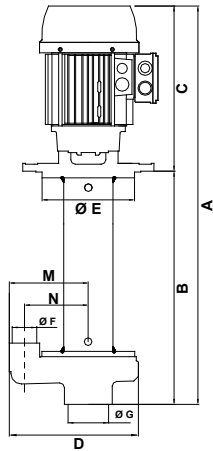

Rating plate data

Type of pump	kW		V 230/400 - Hz 50			Q - maxQ litres/min	maxH - H metres
	Input (P1)	Nom. (P2)	In Amp.	n min ⁻¹	cos φ		
AP 80B	1.86	1.5	5.7/3.3	2845	0.83	65 - 240	25 - 0
AP 90A	2.70	2.2	8.1/4.7	2870	0.83	14 - 382	30 - 0
AP 90B	3.58	3.0	10.6/6.1	2855	0.84	119 - 525	30 - 0

Hydraulic performance curves (closed impeller)

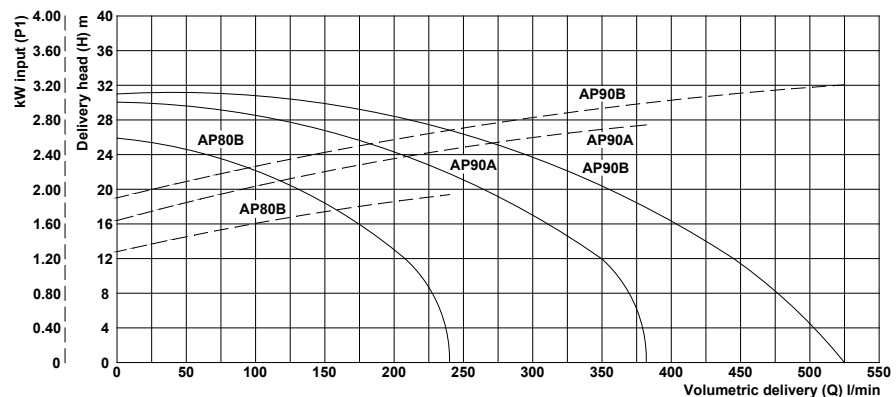

Hydraulic performance table (closed impeller)

Type of pump	Volumetric delivery (Q) l/min ↓												
	0	10	12	14	16	18	20	22	24	26	28	30	
AP 80B	240	222	207	191	173	152	129	106	65				
AP 90A	382	367	350	331	311	289	266	241	211	173	99	14	
AP 90B	525	468	449	423	400	374	346	315	276	237	192	119	

Submersible motor-driven pumps Type AP 80-90 closed impeller

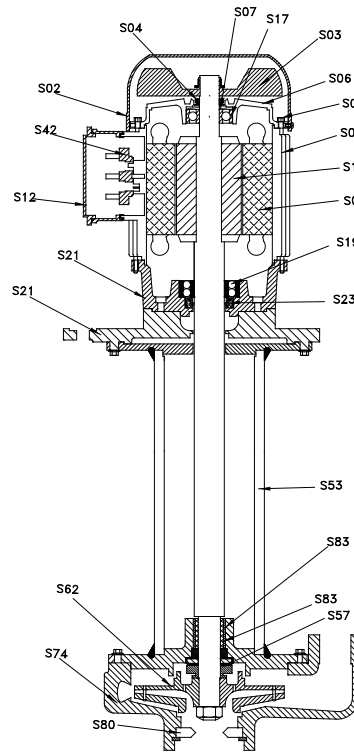

Spare parts nomenclature

Component	
S02.	Fan cover
S03.	Fan
S04.	V-ring
S05.	Stay rod
S06.	Upper shield
S07.	Spring ring
S08.	Housing
S09.	Wound stator
S12.	Terminal box
S17.	Upper bearing
S18.	Axis + Rotor
S19.	Lower bearing
S21.	Motor flange
S21.	Support flange
S23.	Motor seal ring
S42.	Terminal board
S53.	Pump body
S57.	Mechanical seal
S62.	Impeller
S74.	Impeller-cover
S80.	Suction reduction
S83.	IR rings
S83.	Bushing

AP 80	Materials
	Nylon*
	Nylon
	NBR
	Steel
	Aluminium
	Steel
	Aluminium
	-
	Nylon
	-
	Steel
	-
	Cast Iron G20
	Cast Iron G20
	NBR
	-
	Cast Iron G20/Steel
	-
	Cast Iron G20
	Cast Iron G20
	Nylon
	Steel**
	Bronze**

AP 90	Materials
	Nylon*
	Nylon
	NBR
	Steel
	Aluminium
	Steel
	Aluminium
	-
	Nylon
	-
	Steel
	-
	Cast Iron G20
	Cast Iron G20
	NBR
	-
	Cast Iron G20/Steel
	-
	Cast Iron G20
	Cast Iron G20
	Nylon***
	Steel**
	Bronze**

*On demand Sheet metal

** Available only on suction pipe 860

*On demand Sheet metal

** Available only on suction pipe 860

*** Available only for AP90A

Submersible motor-driven pumps Type AP 100-112 closed impeller



Uses

They are suitable for transferring liquids containing impurities up to 2 mm in size.

Their hydraulic components: impeller and feed screw in cast iron, pump body in cast iron/steel allow them to be used with water, emulsions and oily substances in general, with a viscosity not exceeding 21 cSt (3° Engel). The temperature of the liquid must not exceed 90°C.

They are commonly used on:

- **machine tools** (milling and turning machines-machining centres)
- **glass processing machinery**
- **surface treatment plants**
- **filtration systems**

They are normally installed on a tank with a capacity which is proportional to their flow rate, about 6-7 cm from the bottom.

It is important to make sure that the maximum liquid level in the tank is always 3-4 cm lower than the support flange (see figure).

Should the liquid be particularly dirty, it is advisable to build a compartment tank in order to allow the sludge to deposit before it is sucked by the pump.

For different uses, please consult our Technical Office.

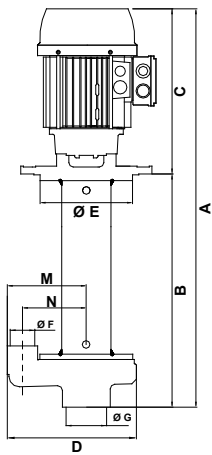

Size and weights table

Type of pump	A mm	B mm	C mm	D mm	ØE mm	ØF	ØG	ØH mm	ØI mm	ØL mm	M mm	N mm	Mass kg
AP 100A	700	320	380	280	240	1 ½"	2 ½"	300	270	13 (n.4)	170	136	37.0
	830	450											43.0
	990	610											46.0
	1240	860											48.0
AP 112B	730	320	410	320	240	2 ½"	2 ½"	300	270	13 (n.4)	190	145	43.0
	860	450											49.0
	1020	610											51.0
	1270	860											53.0

Rating plate data

Type of pump	kW		V 230/400 - Hz 50			Q - maxQ litres/min	maxH - H metres
	Input (P1)	Nom. (P2)	In Amp.	n min ⁻¹	cos φ		
AP 100A	4.85	4	14.9/8.6	2875	0.81	138 - 612	38 - 0
AP 112B	6.57	5.5	18.7/10.8	2900	0.88	73 - 914	34 - 0

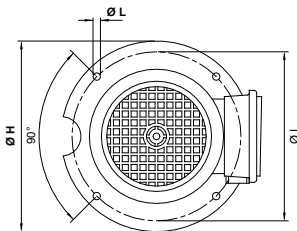

Hydraulic performance curves (closed impeller)

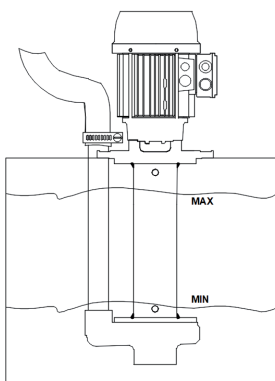
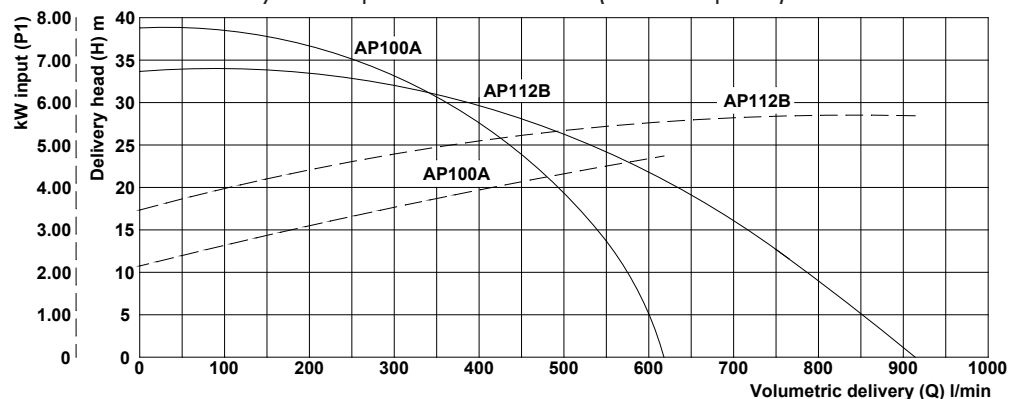

Hydraulic performance table (closed impeller)

Type of pump	Volumetric delivery (Q) l/min ↓															
	0	10	12	14	16	18	20	22	24	26	28	30	32	34	36	38
AP 100A	612	577	561	545	528	511	492	471	450	426	394	360	323	286	234	138
AP 112B	914	786	772	752	731	706	677	635	580	507	432	346	239	73		

Submersible motor-driven pumps Type AP 100-112 closed impeller

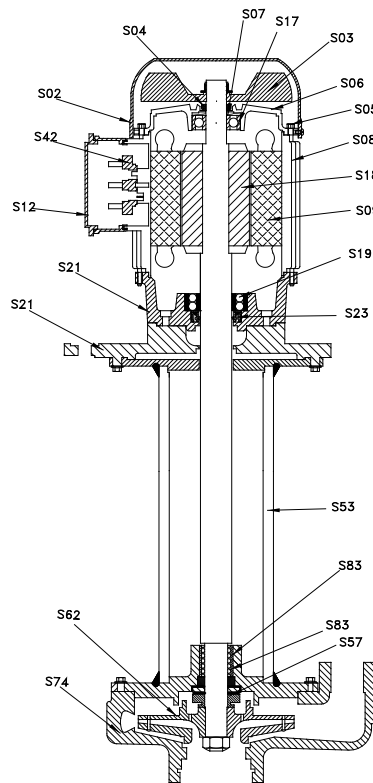

Spare parts nomenclature

Component	
S02.	Fan cover
S03.	Fan
S04.	V-ring
S05.	Stay rod
S06.	Upper shield
S07.	Spring ring
S08.	Housing
S09.	Wound stator
S12.	Terminal box
S17.	Upper bearing
S18.	Axis + Rotor
S19.	Lower bearing
S21.	Motor flange
S21.	Support flange
S23.	Motor seal ring
S42.	Terminal board
S53.	Pump body
S57.	Mechanical seal
S62.	Impeller
S74.	Impeller-cover
S83.	IR rings
S83.	Bushing

AP 100	Materials
	Nylon*
	Nylon
	NBR
	Steel
	Aluminium
	Steel
	Aluminium
	-
	Nylon
	-
	Steel
	-
	Cast Iron G20
	Cast Iron G20
	NBR
	-
	Cast Iron G20/Steel
	-
	Cast Iron G20
	Cast Iron G20
	Steel**
	Bronze**

AP 112	Materials
	Nylon*
	Nylon
	NBR
	Steel
	Aluminium
	Steel
	Aluminium
	-
	Nylon
	-
	Steel
	-
	Cast Iron G20
	Cast Iron G20
	NBR
	-
	Cast Iron G20/Steel
	-
	Cast Iron G20
	Cast Iron G20
	Steel**
	Bronze**

*On demand Sheet metal

** Available only on suction pipe 860

*On demand Sheet metal

** Available only on suction pipe 860

Submersible motor-driven pumps

Type AP 90 open impeller

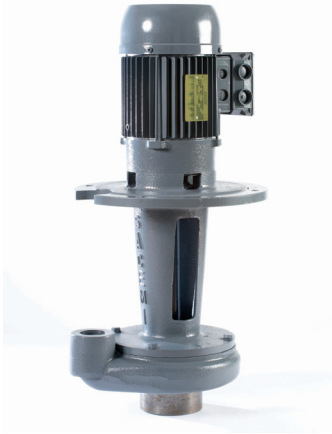

Uses

They are suitable for transferring liquids containing impurities up to 3 mm in size.

Their hydraulic components: impeller and feed screw in cast iron, pump body in cast iron/steel allow them to be used with water, emulsions and oily substances in general, with a viscosity not exceeding 21 cSt (3° Engle). The temperature of the liquid must not exceed 90°C.

They are commonly used on:

- machine tools (milling and turning machines-machining centres)
- glass processing machinery
- surface treatment plants
- filtration systems

They are normally installed on a tank with a capacity which is proportional to their flow rate, about 6-7 cm from the bottom.

It is important to make sure that the maximum liquid level in the tank is always 3-4 cm lower than the support flange (see figure).

Should the liquid be particularly dirty, it is advisable to build a compartment tank in order to allow the sludge to deposit before it is sucked by the pump.

For different uses, please consult our Technical Office.

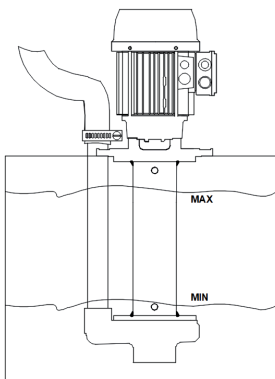
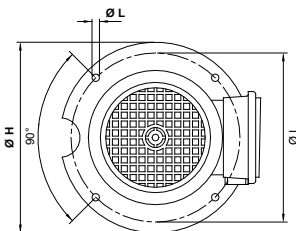
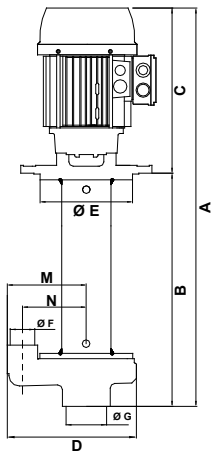

Size and weights table

Type of pump	A mm	B mm	C mm	D mm	ØE mm	ØF	ØG	ØH mm	ØI mm	ØL mm	M mm	N mm	Mass kg
AP 90A	675	320	355	280	240	1 1/2"	2 1/2"	300	270	13 (n.4)	170	136	41.0
	805	450											47.0
	965	610											49.0
	1215	860											51.0
AP 90B	675	320	355	280	240	1 1/2"	2 1/2"	300	270	13 (n.4)	170	136	43.0
	805	450											49.0
	965	610											51.0
	1215	860											53.0

Rating plate data

Type of pump	kW		V 230/400 - Hz 50			Q - Qmax litres/min	Hmax - H metres
	Input (P1)	Nom. (P2)	In Amp.	n min-1	cos φ		
AP 90A	2.70	2.2	8.1/4.7	2870	0.83	85 - 461	26 - 0
AP 90B	3.58	3	10.6/6.10	2850	0.86	66 - 500	26 - 0

Hydraulic performance curves (open impeller)

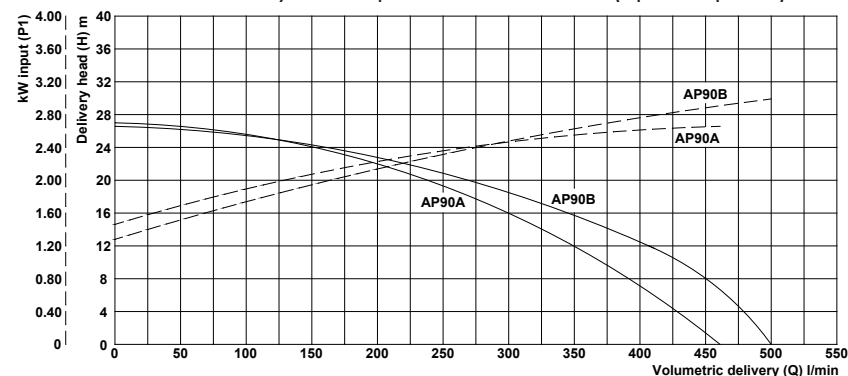

Hydraulic performance table (open impeller)

Type of pump	Volumetric delivery (Q) l/min ↓														
	0	10	12	14	16	18	20	22	24	26	28	30	32	34	36
AP 90A	461	374	351	326	300	270	235	198	154	85					
AP 90B	500	436	403	369	338	309	273	233	178	66					

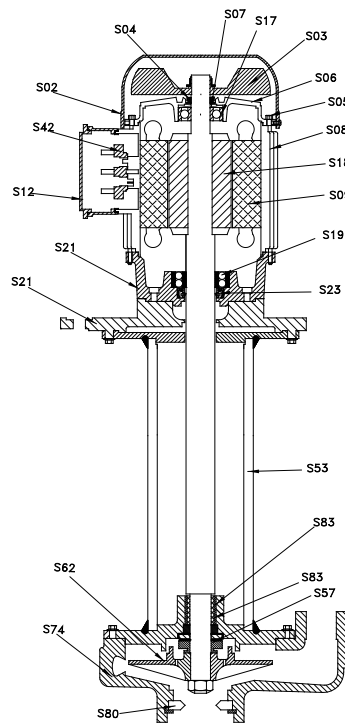

Spare parts nomenclature

Component	
S02.	Fan cover
S03.	Fan
S04.	V-ring
S05.	Stay rod
S06.	Upper shield
S07.	Spring ring
S08.	Housing
S09.	Wound stator
S12.	Terminal box
S17.	Upper bearing
S18.	Axis + Rotor
S19.	Lower bearing
S21.	Motor flange
S21.	Support flange
S23.	Motor seal ring
S42.	Terminal board
S53.	Pump body
S57.	Mechanical seal
S62.	Impeller
S74.	Impeller-cover
S80.	Suction reduction
S83.	IR rings
S83.	Bushing

AP 90	
Materials	
	Nylon*
	Nylon
	NBR
	Steel
	Aluminium
	Steel
	Aluminium
	-
	Nylon
	-
	Steel
	-
	Cast Iron G20
	Cast Iron G20
	NBR
	-
	Cast Iron G20/Steel
	-
	Cast Iron G20
	Cast Iron G20
	Nylon***
	Steel**
	Bronze**

*On demand Sheet metal

** Available only on suction pipe 860

*** Available only for AP90A

Submersible motor-driven pumps Type AP 100-112 open impeller



Uses

They are suitable for transferring liquids containing impurities up to 3 mm in size.

Their hydraulic components: impeller and feed screw in cast iron, pump body in cast iron/steel allow them to be used with water, emulsions and oily substances in general, with a viscosity not exceeding 21 cSt (3° Engel). The temperature of the liquid must not exceed 90°C.

They are commonly used on:

- machine tools (milling and turning machines-machining centres)
- glass processing machinery
- surface treatment plants
- filtration systems

They are normally installed on a tank with a capacity which is proportional to their flow rate, about 6-7 cm from the bottom.

It is important to make sure that the maximum liquid level in the tank is always 3-4 cm lower than the support flange (see figure).

Should the liquid be particularly dirty, it is advisable to build a compartment tank in order to allow the sludge to deposit before it is sucked by the pump.

For different uses, please consult our Technical Office.

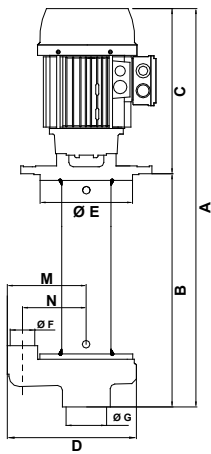

Size and weights table

Type of pump	A mm	B mm	C mm	D mm	ØE mm	ØF	ØG	ØH mm	ØI mm	ØL mm	M mm	N mm	Mass kg
AP 100A	700	320	380	280	240	1 ½"	2 ½"	300	270	13 (n.4)	170	136	37.0
	830	450											43.0
	990	610											46.0
	1240	860											48.0
AP 112B	730	320	410	320	240	2 ½"	2 ½"	300	270	13 (n.4)	170	136	43.0
	860	450											49.0
	1020	610											51.0
	1270	860											53.0

Rating plate data

Type of pump	kW		V 230/400 - Hz 50			Q - maxQ litres/min	maxH - H metres
	Input (P1)	Nom. (P2)	In Amp.	n min ⁻¹	cos φ		
AP 100A	4.85	4	14.9/8.6	2875	0.81	156 - 565	30 - 0
AP 112B	6.57	5.5	18.7/10.8	2900	0.88	48 - 984	32 - 0

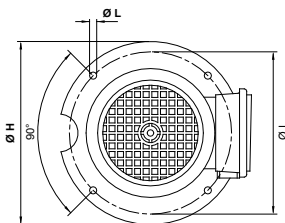

Hydraulic performance curves (open impeller)

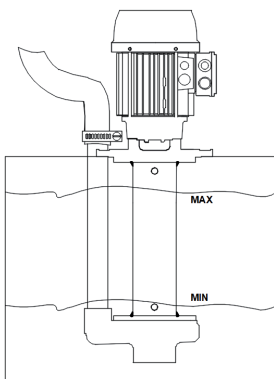
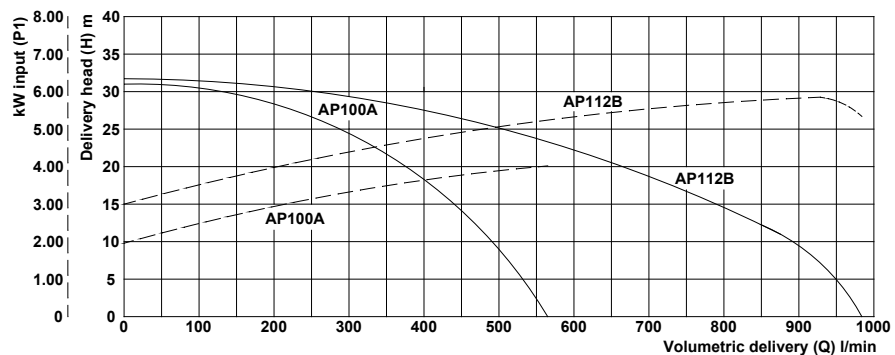

Hydraulic performance table

Type of pump	Volumetric delivery (Q) l/min ↓														
	<10	10	12	14	16	18	20	22	24	26	28	30	32	34	36
AP 100A	565	495	475	454	431	406	375	342	306	270	224	156			
AP 112B	984	893	865	814	765	712	655	596	528	461	372	257	48		

Submersible motor-driven pumps Type AP 100-112 open impeller

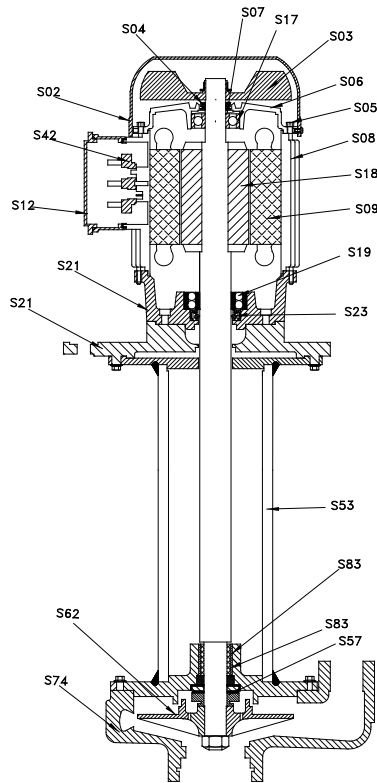

Spare parts nomenclature

Component	
S02.	Fan cover
S03.	Fan
S04.	V-ring
S05.	Stay rod
S06.	Upper shield
S07.	Spring ring
S08.	Housing
S09.	Wound stator
S12.	Terminal box
S17.	Upper bearing
S18.	Axis + Rotor
S19.	Lower bearing
S21.	Motor flange
S21.	Support flange
S23.	Motor seal ring
S42.	Terminal board
S53.	Pump body
S57.	Mechanical seal
S62.	Impeller
S74.	Impeller-cover
S83.	IR rings
S83.	Bushing

AP 100 Materials
Nylon*
Nylon
NBR
Steel
Aluminium
Steel
Aluminium
-
Nylon
-
Steel
-
Cast Iron G20
Cast Iron G20
NBR
-
Cast Iron G20/Steel
-
Cast Iron G20
Cast Iron G20
Steel**
Bronze**

AP 112 Materials
Nylon*
Nylon
NBR
Steel
Aluminium
Steel
Aluminium
-
Nylon
-
Steel
-
Cast Iron G20
Cast Iron G20
NBR
-
Cast Iron G20/Steel
-
Cast Iron G20
Cast Iron G20
Steel**
Bronze**

*On demand Sheet metal

** Available only on suction pipe 860

*On demand Sheet metal

** Available only on suction pipe 860

Submersible motor-driven pumps

Type MP 63-71



Uses

They are suitable for transferring liquids containing impurities up to 3 mm in size. Their hydraulic components: impeller in brass, feed screw and pump body in aluminium allow them to be used with water, emulsions and oily substances in general, with a viscosity not exceeding 21 cSt (3° Engel). The temperature of the liquid must not exceed 90°C.

They are commonly used on:

- machine tools (milling and turning machines-machining centres)
- glass processing machinery
- filtration systems

They are normally installed on a tank with a capacity which is proportional to their flow rate, about 4-5 cm from the bottom.

It is important to make sure that the maximum liquid level in the tank is always 3-4 cm lower than the support flange (see figure).

Should the liquid be particularly dirty, it is advisable to build a compartment tank in order to allow the sludge to deposit before it is sucked by the pump.

For different uses, please consult our Technical Office.

Size and weights table

Type of pump	A mm	B mm	C mm	ØD	ØE mm	ØF mm	ØG mm	H mm	ØI mm	ØL mm	Mass kg
MP 63C	385	180	205	3/4"	128	130	180	190	150	9 (n.4)	6.8
	435	230									6.9
	485	280									7.0
	535	330									7.1
MP 71A	410	180	230	3/4"	128	130	180	190	150	9 (n.4)	8.8
	460	230									9.0
	510	280									9.1
	560	330									9.3
MP 71B	440	210	230	3/4"	128	130	180	190	150	9 (n.4)	10.4
	490	260									10.6
	540	310									10.7
	590	360									10.9

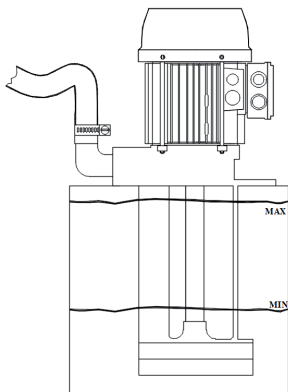
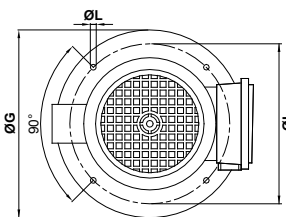
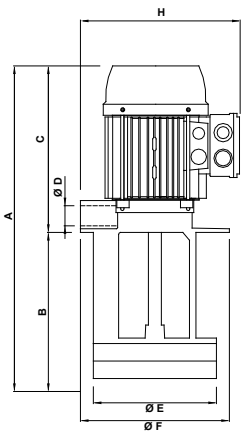

Rating plate data

Type of pump	kW		V 230/400 - Hz 50			Q - maxQ litres/min	maxH - H metres
	Input (P1)	Nom. (P2)	In Amp.	n min ⁻¹	cos φ		
MP 63C	0.74	0.55	2.30/1.33	2755	0.81	6 - 93	18 - 0
MP 71A	1.00	0.75	3.24/1.87	2770	0.77	12 - 103	18 - 0
MP 71B	1.20	0.90	3.83/2.21	2760	0.78	8 - 115	24 - 0

Hydraulic performance curves (open impeller)

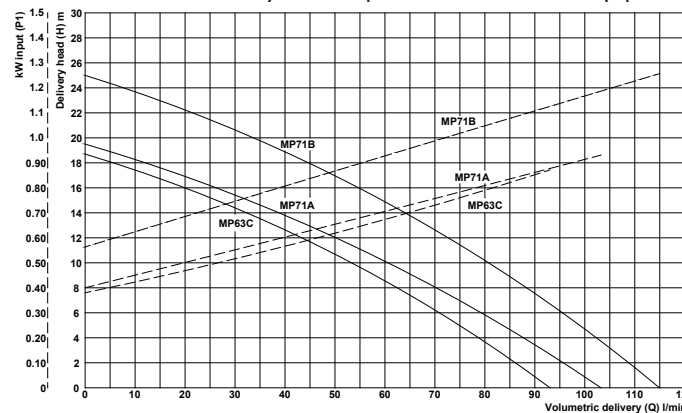

Hydraulic performance table (open impeller)

Delivery head (H) m →	0	2	4	6	8	10	12	14	16	18	20	22	24	26	28
Type of pump	Volumetric delivery (Q) l/min ↓														
MP 63C	93	86	79	71	63	53	43	32	20	6					
MP 71A	103	96	88	79	70	61	50	38	26	12					
MP 71B	115	109	102	96	88	81	73	64	55	45	34	22	8		

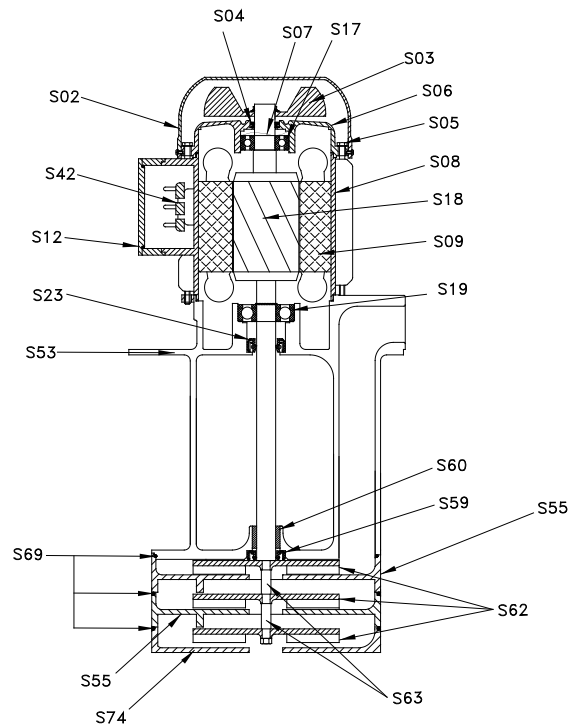

Spare parts nomenclature

		MP 63C
	Component	Materials
S02.	Fan cover	Nylon*
S03.	Fan	Nylon
S04.	V-ring	NBR
S05.	Stay rod	Steel
S06.	Upper shield	Aluminium
S07.	Spring ring	Steel
S08.	Housing	Aluminium
S09.	Wound stator	-
S12.	Terminal box	Nylon
S17.	Upper bearing	-
S18.	Axis + Rotor	Steel**
S19.	Lower bearing	-
S23.	Motor seal ring	NBR
S42.	Terminal board	-
S53.	Pump body	Aluminium
S55.	Diffuser	Aluminium (n° 1)
S59.	Seal	NBR
S60.	Bushing	Bronze
S62.	Impeller	Brass 58
S63.	Spacer ring	Steel
S69.	O-ring	NBR
S74.	Impeller-cover	Aluminium

*On demand Sheet metal
 **On demand.Ax.AISI 416

	MP 71A	MP 71B
	Materials	Materials
	Nylon*	Nylon*
	Nylon	Nylon
	NBR	NBR
	Steel	Steel
	Aluminium	Aluminium
	Steel	Steel
	Aluminium	Aluminium
	-	-
	Nylon	Nylon
	-	-
	Steel**	Steel**
	-	-
	NBR	NBR
	-	-
	Aluminium	Aluminium
	Aluminium (n° 1)	Aluminium (n° 2)
	NBR	NBR
	Bronze	Bronze
	Brass 58	Brass 58
	Steel	Steel
	NBR	NBR
	Aluminium	Aluminium

*On demand Sheet metal *On demand Sheet metal
 **On demand.Ax.AISI 416 **On demand.Ax.AISI 416

Submersible motor-driven pumps

Type MP 80-90-100



Uses

They are suitable for transferring liquids containing impurities up to 3 mm in size. Their hydraulic components: impeller in brass, feed screw and pump body in aluminium allow them to be used with water, emulsions and oily substances in general, with a viscosity not exceeding 21 cSt (3° Engel). The temperature of the liquid must not exceed 90°C.

They are commonly used on:

- **machine tools** (milling and turning machines-machining centres)
- **filtration systems**

They are normally installed on a tank with a capacity which is proportional to their flow rate, about 4-5 cm from the bottom.

It is important to make sure that the maximum liquid level in the tank is always 3-4 cm lower than the support flange (see figure).

Should the liquid be particularly dirty, it is advisable to build a compartment tank in order to allow the sludge to deposit before it is sucked by the pump.

For different uses, please consult our Technical Office.

Size and weights table

Type of pump	A mm	B mm	C mm	ØD	ØE mm	ØF mm	ØG mm	H mm	ØI mm	ØL mm	Mass kg
MP 80C	517	230	287	1"	190	-	230	245	204	9 (n.5)	16.5
	567	280									17.0
	642	355									17.5
	757	470									18.0
MP 90B	590	265	325	1"	190	-	230	255	204	9 (n.5)	22.0
	640	315									22.5
	715	390									23.0
	830	505									23.5
MP 100B	625	265	360	1 ¼"	202	220	250	275	235	9 (n.5)	32.0
	675	315									32.5
	725	365									33.0
	775	415									33.5
	955	595									35.5

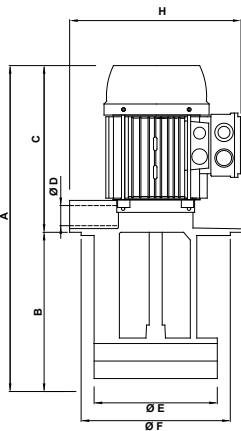

Rating plate data

Type of pump	kW		V 230/400 - Hz 50			Q - maxQ litres/min	maxH - H metres
	Input (P1)	Nom. (P2)	In Amp.	n min ⁻¹	cos φ		
MP 80C	1.86	1.5	5.7/3.3	2845	0.83	22 - 269	28 - 0
MP 90B	3.58	3	10.6/6.10	2850	0.86	17 - 315	45 - 0
MP 100B	4.85	4	14.9/8.6	2875	0.81	37 - 368	50 - 0

Hydraulic performance curves (open impeller)

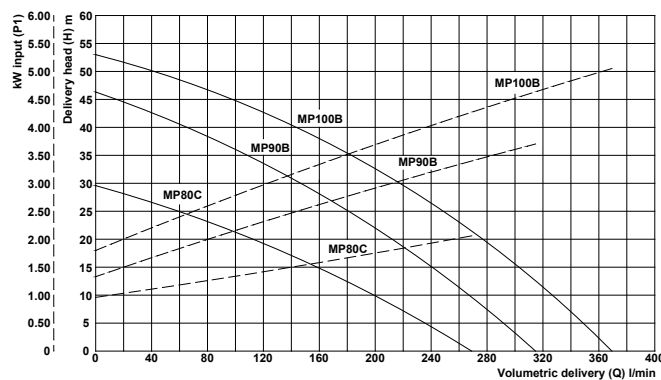

Hydraulic performance table (open impeller)

Delivery head (H) m	0	4	8	12	16	20	24	28	32	36	40	45	50	55	60
Type of pump	Volumetric delivery (Q) l/min ↓														
MP 80C	269	244	215	184	148	106	68	22							
MP 90B	307	293	276	257	236	213	187	159	130	97	63	17			
MP 100B	360	349	333	316	297	280	256	233	207	178	141	94	37		

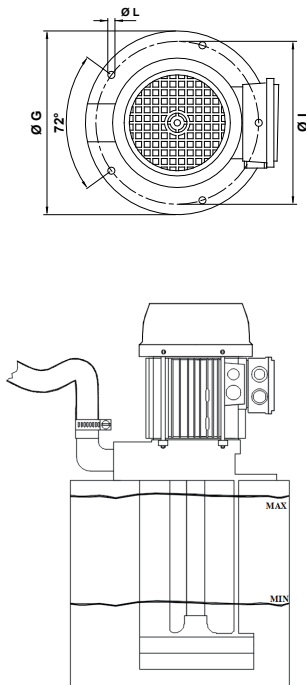

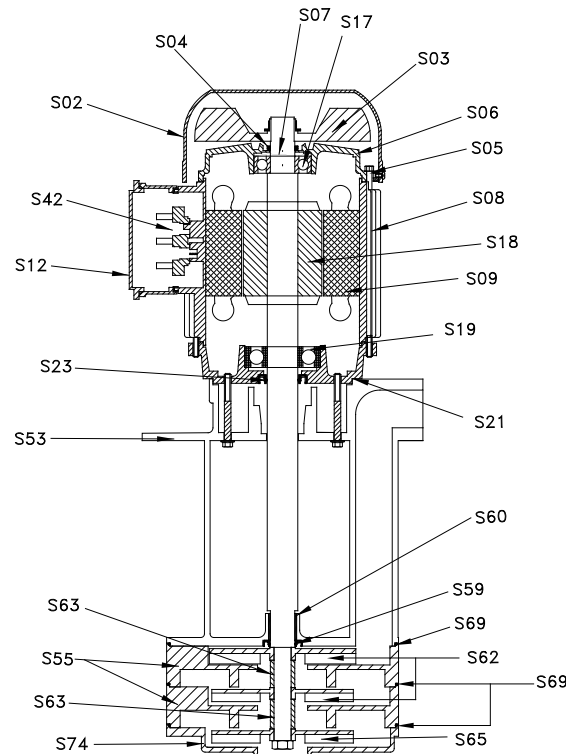

Spare parts nomenclature

	Component
S02.	Fan cover
S03.	Fan
S04.	V-ring
S05.	Stay rod
S06.	Upper shield
S07.	Spring ring
S08.	Housing
S09.	Wound stator
S12.	Terminal box
S17.	Upper bearing
S18.	Axis + Rotor
S19.	Lower bearing
S23.	Motor seal ring
S42.	Terminal board
S53.	Pump body
S55.	Diffuser
S59.	Seal
S60.	Bushing
S62.	High impeller
S63.	Upper spacer ring
S63.	Lower spacer ring
S65.	Low impeller
S69.	O-ring
S74.	Impeller-cover

MP 80C	MP 90B	MP 100B
Materials	Materials	Materials
Nylon*	Nylon*	Nylon*
Nylon	Nylon	Nylon
NBR	NBR	NBR
Steel	Steel	Steel
Aluminium	Aluminium	Aluminium
Steel	Steel	Steel
Aluminium	Aluminium	Aluminium
-	-	-
Nylon	Nylon	Nylon
-	-	-
Steel	Steel	Steel
-	-	-
NBR	NBR	NBR
-	-	-
Aluminium	Aluminium	Aluminium
Aluminium (no 1)	Aluminium (no 2)	Aluminium (no 2)
NBR	NBR	NBR
Bronze	Bronze	Bronze
Brass 58	Brass 58	Cast Iron G20
Steel	Steel	Steel
Not available	Steel	Steel
Brass 58	Brass 58	Cast Iron G20
NBR	NBR	NBR
Aluminium	Aluminium	Aluminium

*On demand Sheet metal *On demand Sheet metal *On demand Sheet metal

Submersible motor-driven pumps

Type MPC



Uses

They are suitable for transferring liquids containing impurities up to 2 mm in size. Their hydraulic components: impeller in brass, feed screw and pump body in aluminium allow them to be used with water, emulsions and oily substances in general, with a viscosity not exceeding 21 cSt (3° Engel). The temperature of the liquid must not exceed 90°C.

They are commonly used on:

- **machine tools** (milling and turning machines-machining centres)
- **filtration systems**

They are normally installed on a tank with a capacity which is proportional to their flow rate, about 4-5 cm from the bottom. It is important to make sure that the maximum liquid level in the tank is always 3-4 cm lower than the support flange (see figure). Should the liquid be particularly dirty, it is advisable to build a compartment tank in order to allow the sludge to deposit before it is sucked by the pump.

For different uses, please consult our Technical Office.

Size and weights table

Type of pump	A mm	B mm	C mm	ØD	ØE mm	ØF mm	ØG mm	H mm	ØI mm	ØL mm	Mass kg
MPC 80B	490	210	280	1"	190	-	230	245	204	9 (n.5)	16.0
	540	260									16.1
	615	335									16.2
	730	450									18.0
MPC 80C	520	240	280	1"	190	-	230	245	204	9 (n.5)	17.9
	570	290									18.0
	645	365									18.1
	760	480									19.0
MPC 90B	583	260	323	1"	190	-	230	255	204	9 (n.5)	25.5
	633	310									25.6
	708	385									25.7
	823	500									27.5
MPC 100B	650	280	370	1 1/4"	202	220	250	275	235	9 (n.5)	38.5
	700	330									39.0
	750	380									39.5
	800	430									40.0
	980	610									42.2

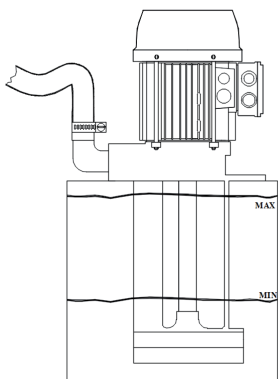
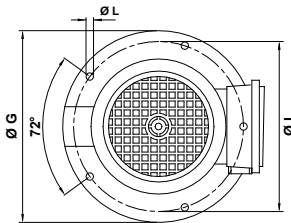
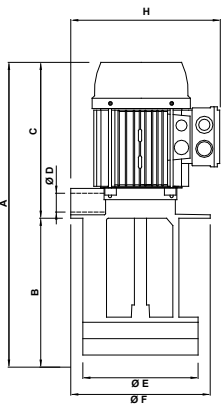

Rating plate data

Type of pump	kW		V 230/400 - Hz 50			Q - maxQ litres/min	maxH - H metres
	Input (P1)	Nom. (P2)	In Amp.	n min ⁻¹	cos φ		
MPC 80B	1.41	1.1	4.3/2.5	2825	0.81	5 - 131	25 - 0
MPC 80C	1.86	1.5	5.7/3.3	2845	0.83	40 - 151	40 - 0
MPC 90B	2.70	2.2	8.1/4.7	2870	0.83	40 - 154	60 - 0
MPC 100B	4.85	4	14.9/8.6	2875	0.81	27 - 160	80 - 0

Hydraulic performance curves (closed impeller)

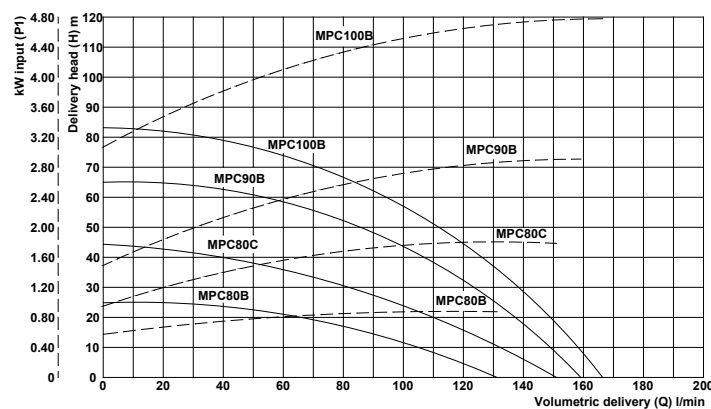

Hydraulic performance table (closed impeller)

Type of pump	Volumetric delivery (Q) l/min ↓															
	0	5	10	15	20	25	30	35	40	45	50	60	70	80	90	100
MPC 80B	131	119	109	88	58	5										
MPC 80C	151	142	134	124	118	102	93	71	40							
MPC 90B	150	152	149	145	140	135	126	118	107	94	78	40				
MPC 100B	160	156	154	152	149	146	142	135	128	121	113	93	60	27		

Submersible motor-driven pumps

Type MPC

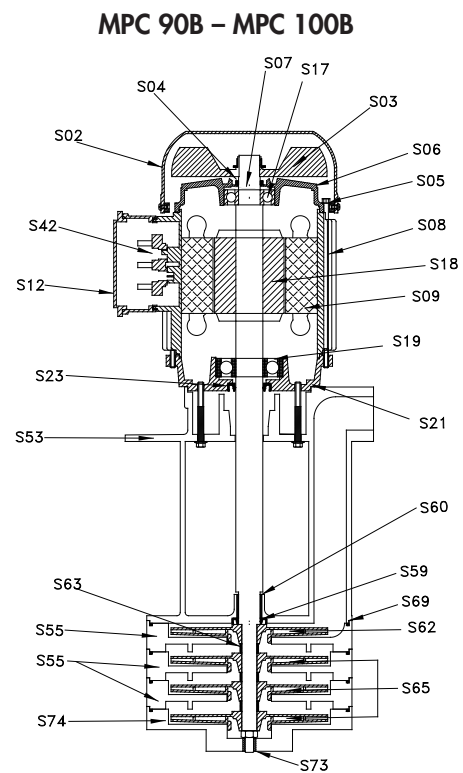
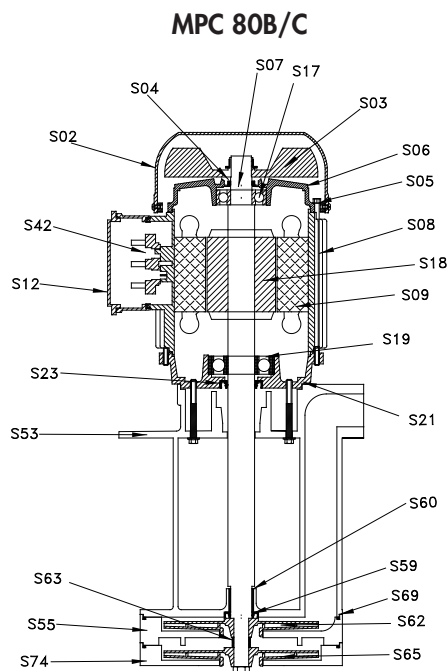

Spare parts nomenclature

Component	MPC 80B/C Materials	MPC 90B Materials	MPC 100B Materials
S02. Fan cover	Nylon*	Nylon*	Nylon*
S03. Fan	Nylon	Nylon	Nylon
S04. V-ring	NBR	NBR	NBR
S05. Stay rod	Steel	Steel	Steel
S06. Upper shield	Aluminium	Aluminium	Aluminium
S07. Spring ring	Steel	Steel	Steel
S08. Housing	Aluminium	Aluminium	Aluminium
S09. Wound stator	-	-	-
S12. Terminal box	Nylon	Nylon	Nylon
S17. Upper bearing	-	-	-
S18. Axis + Rotor	Steel	Steel	Steel
S19. Lower bearing	-	-	-
S21. Flange	Aluminium	Aluminium	Aluminium
S23. Motor seal ring	NBR	NBR	NBR
S42. Terminal board	-	-	-
S53. Pump body	Aluminium	Aluminium	Aluminium
S55. Upper diffuser	Aluminium (80C)	Aluminium	Aluminium
S55. Intermediate diffuser	Not available	Not available	Aluminium
S59. Seal	NBR	NBR	NBR
S60. Bushing	Bronze	Bronze	Bronze
S62. High impeller	Brass 58	Brass 58	Brass 58
S63. Spacer ring	Steel (80C)	Steel	Steel
S65. Low impeller	Brass 58	Brass 58	Brass 58
S69. O-ring	NBR	NBR	NBR
S73. Lower bushing	Not available	Not available	Bronze
S74. Impeller-cover	Aluminium	Aluminium	Aluminium

*On demand Sheet metal

*On demand Sheet metal

*On demand Sheet metal

Submersible motor-driven pumps

Type MSPV



Uses

They are suitable for transferring liquids containing impurities up to 3 mm in size. Their hydraulic components: impeller, feed screw and pump body in PBT allow them to be used with emulsions and oily substances in general, with a viscosity not exceeding 21 cSt (3° Englel). The temperature of the liquid must not exceed 90°C.

They are commonly used on:

- machine tools (milling and turning machines-machining centres)
- glass processing machinery
- printing machines
- filtration systems
- air-conditioning systems

They are normally installed on a tank with a capacity which is proportional to their flow rate, about 4-5 cm from the bottom.

It is important to make sure that the maximum liquid level in the tank is always 3-4 cm lower than the support flange (see figure).

Should the liquid be particularly dirty, it is advisable to build a compartment tank in order to allow the sludge to deposit before it is sucked by the pump.

For different uses, please consult our Technical Office.

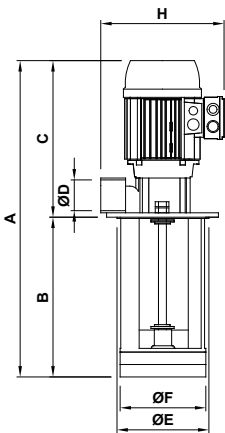

Size and weights table

Type of pump	A mm	B mm	C mm	ØD	ØE mm	ØF mm	ØG mm	H mm	ØI mm	ØL mm	Mass kg
MSPV 71	500	230	270	1 ¼"	139	138	178	215	160	9 (n.4)	9.7
	570	300									9.8
	650	380									9.9
MSPV 80	560	260	300	1 ¼"	139	138	178	230	160	9 (n.4)	13.7
	630	330									13.9
	710	410									14.0

Rating plate data

Type of pump	kW		V 230/400 - Hz 50			Q - Qmax litres/min	maxH - H metres
	Input (P1)	Nom. (P2)	In Amp.	n min ⁻¹	cos φ		
MSPV 71	1.34	1.00	4.24/2.45	2760	0.79	22 - 185	18 - 0
MSPV 80	1.86	1.5	5.7/3.3	2845	0.83	16 - 158	26 - 0

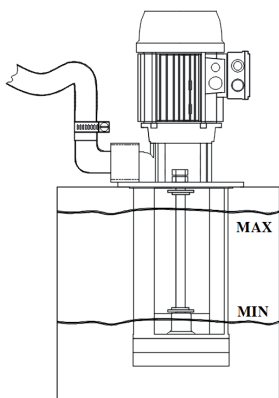
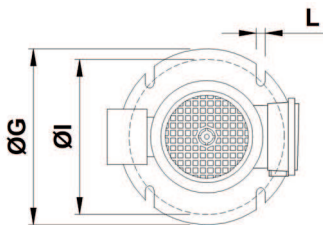

Hydraulic performance curves (open impeller)

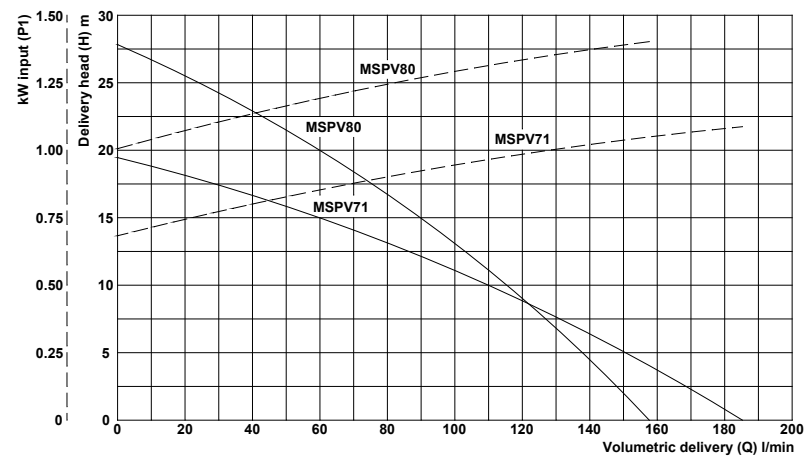

Hydraulic performance table (open impeller)

Delivery head (H) m	0	2	4	6	8	10	12	14	16	18	20	22	24	26	28
Type of pump	Volumetric delivery (Q) l/min ↓														
MSPV 71	185	172	161	147	129	112	88	65	45	22					
MSPV 80	158	150	143	134	125	116	106	95	83	71	59	45	32	16	

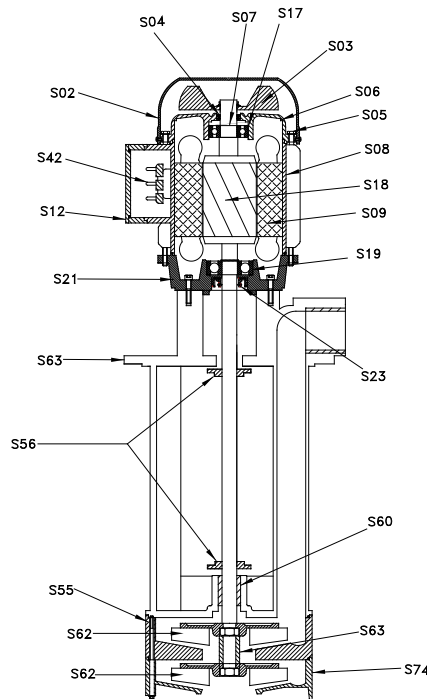

Spare parts nomenclature

	Component
S02.	Fan cover
S03.	Fan
S04.	V-ring
S05.	Stay rod
S06.	Upper shield
S07.	Spring ring
S08.	Housing
S09.	Wound stator
S12.	Terminal box
S17.	Upper bearing
S18.	Axis + Rotor
S19.	Lower bearing
S21.	Motor flange
S21.	Support flange
S23.	Motor seal ring
S42.	Terminal board
S53.	Pump body
S55.	Diffuser
S56.	TRI washer
S60.	Bushing
S62.	Impeller
S63.	Spacer ring
S74.	Impeller-cover

MSPV 71	Materials
	Nylon*
	Nylon
	NBR
	Steel
	Aluminium
	Steel
	Aluminium
	-
	Nylon
	-
	AISI 416
	-
	Cast Iron G20
	Cast Iron G20
	NBR
	-
	Nylon
	Nylon
	PBT
	Engineering plastic
	PBT
	AISI 416
	PBT

MSPV 80	Materials
	Nylon*
	Nylon
	NBR
	Steel
	Aluminium
	Steel
	Aluminium
	-
	Nylon
	-
	AISI 416
	-
	Cast Iron G20
	Cast Iron G20
	NBR
	-
	Nylon
	Nylon
	PBT
	Engineering plastic
	PBT
	AISI 416
	PBT

*On demand Sheet metal

*On demand Sheet metal

Submersible motor-driven pumps

Type EPC 63-71



Uses

They are suitable for transferring clean liquids containing impurities up to 0.03 mm in size. Their hydraulic components: impeller in brass, feed screw and pump body in cast-iron allow them to be used with emulsions and oily substances, glycol and liquids in general provided they are not oxidative for the construction materials.

Viscosity must not exceed 21 cST (3° Engel).

The temperature of the liquid must not exceed 90°C.

They are commonly used on:

- drilling centres
- cooling units

They are normally installed on a tank with a capacity which is proportional to their flow rate, about 3-4 cm from the bottom.

It is important to make sure that the maximum liquid level in the tank is always 3-4 cm lower than the support flange (see figure).

For different uses, please consult our Technical Office.

Size and weights table

Type of pump	A mm	B mm	C mm	ØD	ØE mm	ØF mm	ØG mm	H mm	ØI mm	ØL mm	Mass kg
EPC 63C	310	100	210	3/4"	98	100	130	185	115	7 (n.4)	8.9
	340	130									9.2
	390	180									9.4
	440	230									9.6
	490	280									9.8
	570	360									10.3
EPC 71B	360	100	260	3/4"	98	100	130	193	115	7 (n.4)	11.6
	390	130									11.9
	440	180									12.1
	490	230									12.3
	540	280									12.5
	620	360									13.0

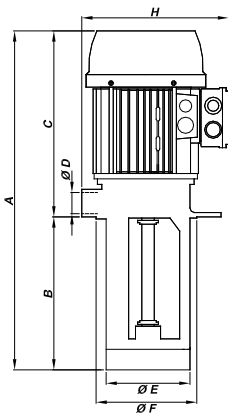

Rating plate data

Type of pump	kW		V 230/400 - Hz 50			Q - Q _{max} litres/min	H _{max} - H metres
	Input (P1)	Nom. (P2)	I _n Amp.	n min ⁻¹	cos φ		
EPC 63C	0.50	0.37	1.60/0.92	2825	0.79	1 - 47	35 - 0
EPC 71B	1.20	0.90	3.83/2.21	2760	0.78	1 - 62	55 - 0

Hydraulic performance curves (peripheral impeller)

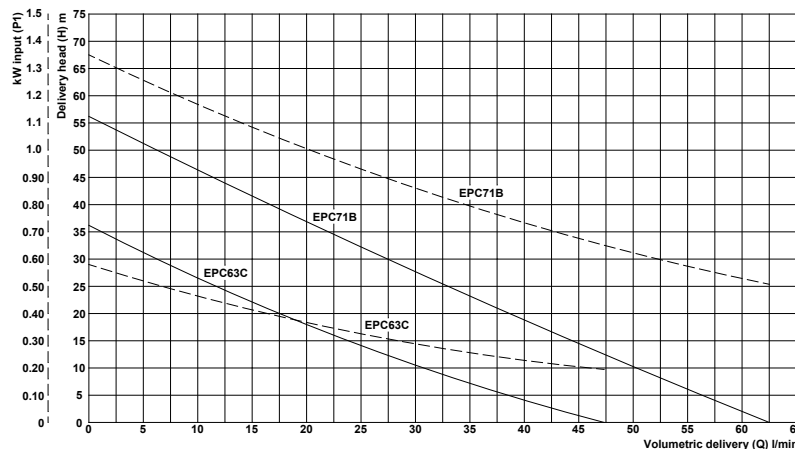

Hydraulic performance table (peripheral impeller)

Type of pump	Volumetric delivery (Q) l/min ↓														
	0	5	10	15	20	25	30	35	40	45	50	55	60	65	70
EPC 63C	47	37	31	23	18	12	6	1							
EPC 71B	62	56	50	44	38	33	27	22	17	12	6	1			

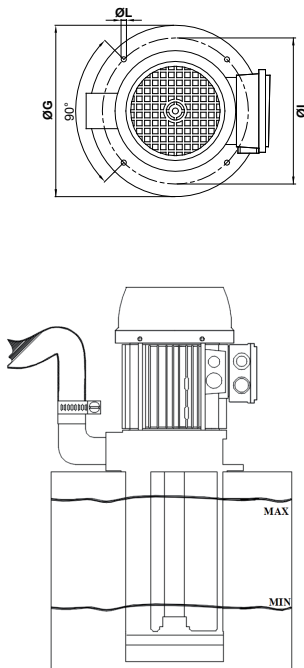

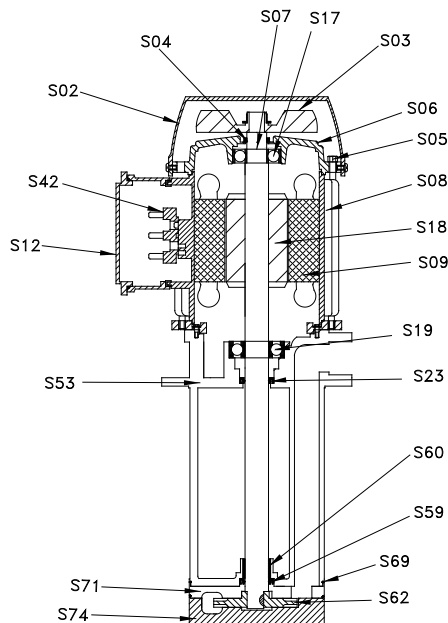

Spare parts nomenclature

Component	
S02.	Fan cover
S03.	Fan
S04.	V-ring
S05.	Stay rod
S06.	Upper shield
S07.	Spring ring
S08.	Housing
S09.	Wound stator
S12.	Terminal box
S17.	Upper bearing
S18.	Axis + Rotor
S19.	Lower bearing
S23.	Motor seal ring
S42.	Terminal board
S53.	Pump body
S59.	Seal
S60.	Bushing
S62.	Impeller
S69.	O-ring
S71.	Adaptor coupling
S74.	Impeller-cover

EPC 63C	
Materials	
	Nylon*
	Nylon
	NBR
	Steel
	Aluminium
	Steel
	Aluminium
	-
	Nylon
	-
	Steel**
	-
	NBR
	-
	Cast Iron G20
	NBR
	Bronze
	Brass 58
	NBR
	Cast Iron G20
	Cast Iron G20

EPC 71B	
Materials	
	Nylon*
	Nylon
	NBR
	Steel
	Aluminium
	Steel
	Aluminium
	-
	Nylon
	-
	Steel**
	-
	NBR
	-
	Cast Iron G20
	NBR
	Bronze
	Brass 58
	NBR
	Cast Iron G20
	Cast Iron G20

*On demand Sheet metal
 **On demand. Ax. AISI 416

*On demand Sheet metal
 **On demand. Ax. AISI 416

Submersible motor-driven pumps

Type EPC 80-90



Uses

They are suitable for transferring clean liquids containing impurities up to 0.03 mm in size. Their hydraulic components: impeller in brass, feed screw and pump body in cast-iron allow them to be used with emulsions and oily substances, glycol and liquids in general provided they are not oxidative for the construction materials. Viscosity must not exceed 21 cST (3° Engle). The temperature of the liquid must not exceed 90°C. They are commonly used on:

- drilling centres
- cooling units

They are normally installed on a tank with a capacity which is proportional to their flow rate, about 3-4 cm from the bottom.

It is important to make sure that the maximum liquid level in the tank is always 3-4 cm lower than the support flange (see figure).

For different uses, please consult our Technical Office.

Size and weights table

Type of pump	A mm	B mm	C mm	ØD	ØE mm	ØF mm	ØG mm	H mm	ØI mm	ØL mm	Mass kg
EPC 80B	381	100									15.3
	411	130									15.6
	461	180	281	3/4"	98	100	130	200	115	7 (n.4)	15.8
	511	230									16.0
	561	280									16.2
EPC 90A	641	360									16.8
	435	115									17.2
	465	145									17.5
	515	195	320	3/4"	98	100	130	220	115	7 (n.4)	17.7
	565	245									17.9
EPC 90B	615	295									18.1
	695	375									18.6
	460	140									30.3
	490	170									30.6
	540	220	320	3/4"	98	100	130	220	115	7 (n.4)	30.8
EPC 90B	590	270									31.0
	640	320									31.2
	720	400									31.8

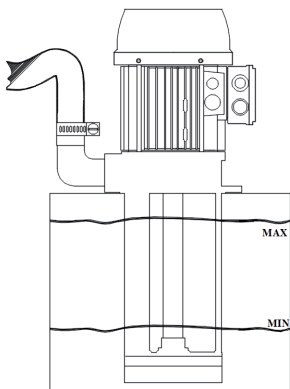
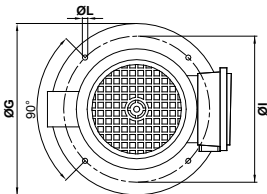
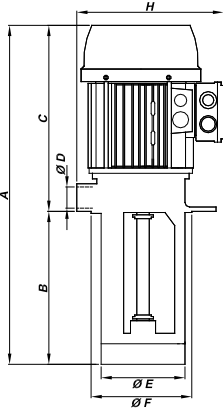

Rating plate data

Type of pump	kW		V 230/400 - Hz 50			Q - Q _{max} litres/min	H _{max} - H metres
	Input (P1)	Nom. (P2)	In Amp.	n min ⁻¹	cos φ		
EPC 80B	1.86	1.5	5.7/3.3	2845	0.83	9 - 74	70 - 0
EPC 90A	2.28	1.8	7.3/4.2	2850	0.78	8 - 78	80 - 0
EPC 90B	3.58	3	10.6/6.1	2855	0.84	5 - 80	120 - 0

Hydraulic performance curves (peripheral impeller)

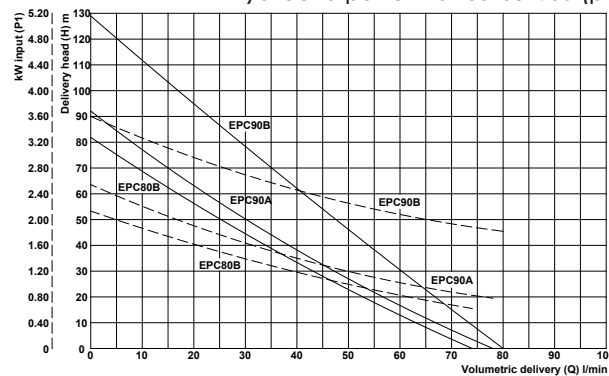

Hydraulic performance table (peripheral impeller)

Type of pump	Volumetric delivery (Q) l/min ↓														
	0	5	10	15	20	30	40	50	60	70	80	90	100	110	120
EPC 80B	74	68	63	57	53	43	34	25	17	9					
EPC 90A	78	72	67	62	57	47	38	30	23	15	8				
EPC 90B	80	76	73	70	67	60	54	48	41	35	29	23	17	11	5

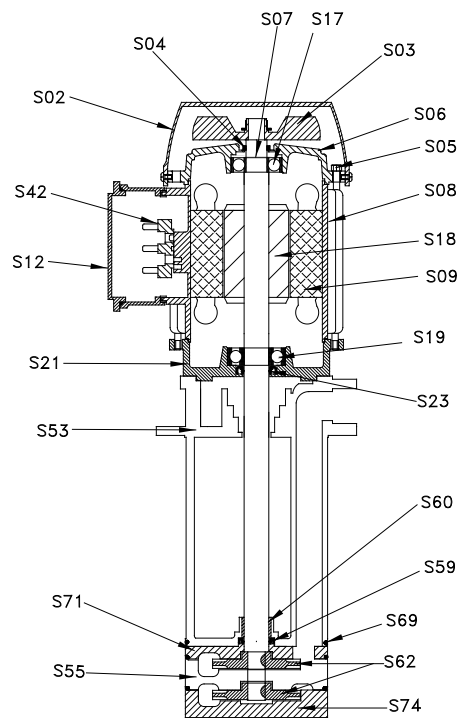

Spare parts nomenclature

Component		EPC 80B Materials	EPC 90A Materials	EPC 90B Materials
S02.	Fan cover	Nylon*	Nylon*	Nylon*
S03.	Fan	Nylon	Nylon	Nylon
S04.	V-ring	NBR	NBR	NBR
S05.	Stay rod	Steel	Steel	Steel
S06.	Upper shield	Aluminium	Aluminium	Aluminium
S07.	Spring ring	Steel	Steel	Steel
S08.	Housing	Aluminium	Aluminium	Aluminium
S09.	Wound stator	-	-	-
S12.	Terminal box	Nylon	Nylon	Nylon
S17.	Upper bearing	-	-	-
S18.	Axis + Rotor	Steel**	Steel**	Steel**
S19.	Lower bearing	-	-	-
S21.	Flange	Aluminium	Aluminium	Aluminium
S23.	Motor seal ring	NBR	NBR	NBR
S42.	Terminal board	-	-	-
S53.	Pump body	Cast Iron G20	Cast Iron G20	Cast Iron G20
S55.	Diffuser	Not available	Cast Iron G20 (n° 1)	Cast Iron G20 (n° 1)
S59.	Seal	NBR	NBR	NBR
S60.	Bushing	Bronze	Bronze	Bronze
S62.	Impeller	Brass 58 (no 1)	Brass 58 (no 2)	Brass 58 (no 3)
S69.	Feed screw O-ring	NBR (no 2)	NBR (no 3)	NBR (no 4)
S71.	Adaptor coupling	Cast Iron G20	Cast Iron G20	Cast Iron G20
S74.	Impeller-cover	Cast Iron G20	Cast Iron G20	Cast Iron G20

*On demand Sheet metal

**On demand Ax.AISI 416

*On demand Sheet metal

**On demand Ax.AISI 416

*On demand Sheet metal

**On demand Ax.AISI 416

Submersible motor-driven pumps

Type PPI



Uses

They are suitable for transferring liquids containing impurities up to 0.03 mm in size. Their hydraulic components: impeller, feed screw and pump body in brass allow them to be used with emulsions and oily substances, glycol and liquids in general provided they are not oxidative for the construction materials. Viscosity must not exceed 21 cST (3° Engle).

The temperature of the liquid must not exceed 90°C.

When using diathermic oil, the fluid temperature can reach 150°C.

They are commonly used on:

- **temperature regulation systems**

They are normally installed on a tank with a capacity which is proportional to their flow rate, about 3-4 cm from the bottom.

It is important to make sure that the maximum liquid level in the tank is always 3-4 cm lower than the support flange (see figure).

For different uses, please consult our Technical Office.

Size and weights table

Type of pump	A mm	B mm	C mm	ØD	ØE mm	ØF mm	ØG mm	H mm	ØI mm	ØL mm	Mass kg
PPI 63C	437	195	242	3/4"	98	100	130	185	115	7 (n.4)	9.1
PPI 71B	466	200	266	3/4"	98	100	130	193	115	7 (n.4)	11.4

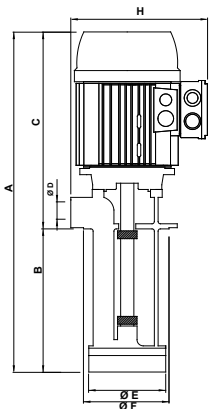

Rating plate data

Type of pump	kW		V 230/400 - Hz 50			Q - Q _{max} litres/min	H _{max} - H metres
	Input (P1)	Nom. (P2)	In Amp.	n min ⁻¹	cos φ		
PPI 63C	0.74	0.55	2.30/1.33	2755	0.81	1 - 48	35 - 0
PPI 71B	1.20	0.90	3.83/2.21	2760	0.78	5 - 61	45 - 0

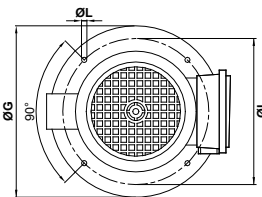

Hydraulic performance curves (peripheral impeller)

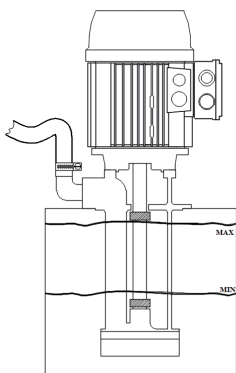
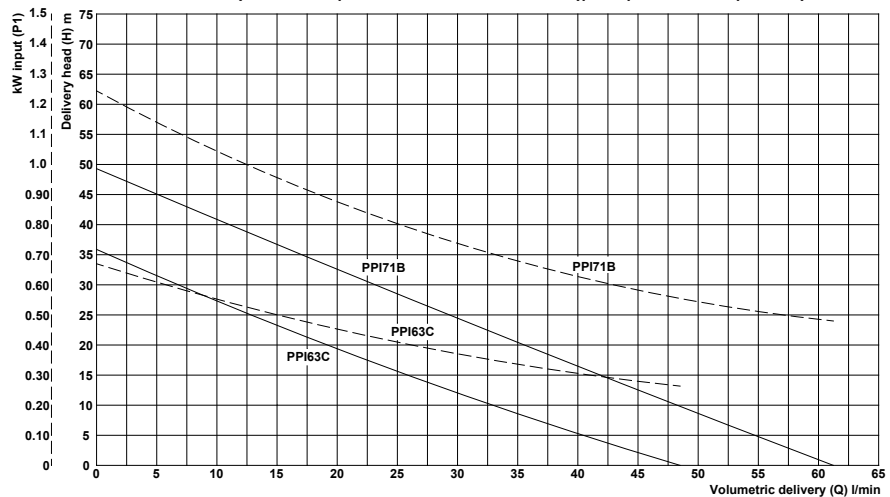

Hydraulic performance table (peripheral impeller)

Delivery head (H) m	0	5	10	15	20	25	30	35	40	45	50	55	60	65	70
→															
Type of pump	Volumetric delivery (Q) l/min ↓														
PPI 63C	48	41	33	26	19	13	7	1							
PPI 71B	61	55	48	42	36	29	23	17	11	5					

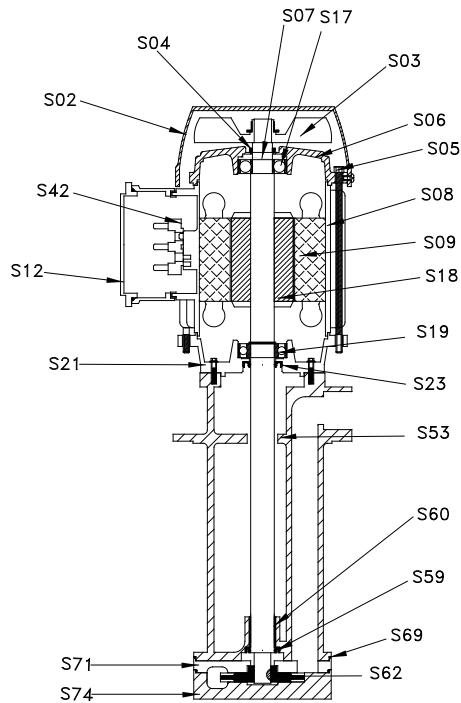

Spare parts nomenclature

	Component
S02.	Fan cover
S03.	Fan
S04.	V-ring
S05.	Stay rod
S06.	Upper shield
S07.	Spring ring
S08.	Housing
S09.	Wound stator
S12.	Terminal box
S17.	Upper bearing
S18.	Axis + Rotor
S19.	Lower bearing
S21.	Motor flange
S23.	Motor seal ring
S42.	Terminal board
S53.	Pump body
S59.	Seal
S62.	Impeller
S60.	Self-lubricating bush
S69.	O-ring
S71.	Adaptor coupling
S74.	Impeller-cover

PPI 63C	Materials
	Nylon*
	Nylon
	NBR
	Steel
	Aluminium
	Steel
	Aluminium
	-
	Aluminium
	-
	(Ax.AISI 416)
	-
	Aluminium
	NBR
	-
	Brass 58
	NBR
	Brass 58
	AISI 304
	NBR
	Brass 58
	Brass 58

PPI 71B	Materials
	Nylon*
	Nylon
	NBR
	Steel
	Aluminium
	Steel
	Aluminium
	-
	Aluminium
	-
	(Ax.AISI 416)
	-
	Aluminium
	NBR
	-
	Brass 58
	NBR
	Brass 58
	AISI 304
	NBR
	Brass 58
	Brass 58

*On demand Sheet metal

*On demand Sheet metal

Vertical multistage pumps

Type HPP 80



Main applications

The pump is designed for pumping clean and non-explosive liquids without abrasive and filamentous suspended parts and with a viscosity not exceeding 20mm²/s.

The pump is designed for industrial applications:

- Machine tools (grinding, lathes, drilling centres)
- Glass processing machinery
- Filtration systems
- Cooling systems
- Washing machines

Operating conditions

Liquid temperature from -15 °C to + 90 °C - Maximum room temperature + 40 °C.

Electric motor:

The pump is equipped with a closed construction engine, with external ventilation, built in accordance with IEC 60034-30-1 in efficiency class IE3 (Premium Efficiency).

Degree of protection IP 55

Size and weights table

Type of pump	A mm	B mm	C mm	D mm	E mm	F mm	Mass kg
HPP 80/2	535	192	343	123	99	80.5	15.5
HPP 80/4	589	246	343	123	99	80.5	18.0
HPP 80/6	643	300	343	123	99	80.5	20.5

Rating plate data

Type of pump	kW		V 230/400 - Hz 50						Q _{max} - Q litres/min	H - H _{max} metres
	Input (P1)	Nom. (P2)	In Amp.	n min ⁻¹	cos φ	50%	IE3 η 75%	100%		
HPP 80/2	0.91	0.75	2.84/1.64	2845	0.80	81.9	83.2	82.5	109 - 73	12 - 16
HPP 80/4	0.91	0.75	2.84/1.64	2845	0.80	81.9	83.2	82.5	125 - 82	14 - 30
HPP 80/6	1.30	1.1	4.09/2.36	2865	0.80	83.9	85.3	84.8	138 - 49	16 - 50

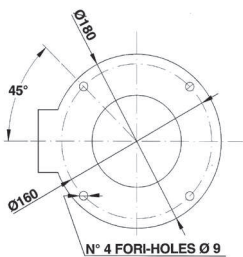
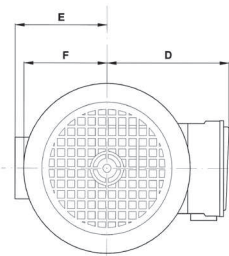
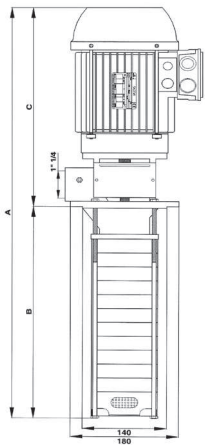

Hydraulic performance curves

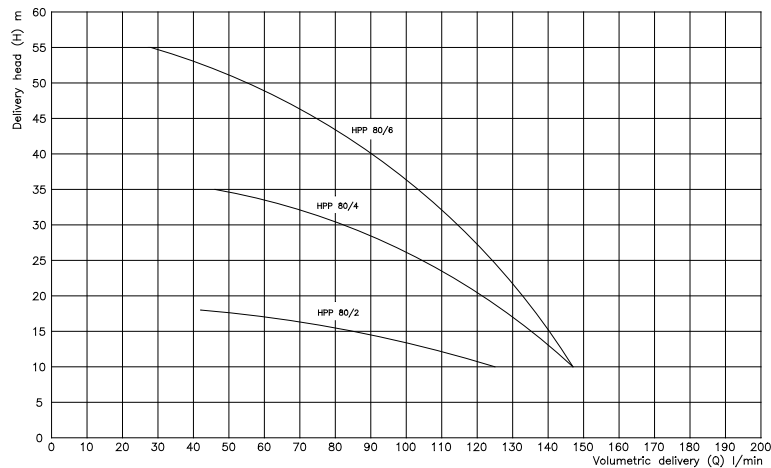

Hydraulic performance table

Delivery head (H) m →	Volumetric delivery (Q) l/min ↓													
	10	12	14	16	18	20	25	30	35	40	45	50	55	60
Type of pump														
HPP 80/2	125	109	98	73	42									
HPP 80/4	147	141	138	133	127	123	106	82	46					
HPP 80/6	147	144	141	138	136	133	124	115	104	89	75	49	28	

Vertical multistage pumps

Type HPP 90



Main applications

The pump is designed for pumping clean and non-explosive liquids without abrasive and filamentous suspended parts and with a viscosity not exceeding 20mm²/s.

The pump is designed for industrial applications:

- Machine tools (grinding, lathes, drilling centres)
- Glass processing machinery
- Filtration systems
- Cooling systems
- Washing machines

Operating conditions

Liquid temperature from -15 ° C to + 90 ° C - Maximum room temperature + 40 ° C.

Electric motor:

The pump is equipped with a closed construction engine, with external ventilation, built in accordance with IEC 60034-30-1 in efficiency class IE3 (Premium Efficiency).
Degree of protection IP 55

Size and weights table

Type of pump	A mm	B mm	C mm	D mm	E mm	F mm	Mass kg
HPP 90/8	740	354	386	129	99	89.5	25.5
HPP 90/10	794	408	386	129	99	89.5	29.0
HPP 90/12	848	462	386	129	99	89.5	30.0

Rating plate data

Type of pump	kW		V 230/400 - Hz 50						Q _{max} - Q litres/min	H - H _{max} metres
	Input (P1)	Nom. (P2)	In Amp.	n min ⁻¹	cos φ	50%	IE3 75% η	100%		
HPP 90/8	1.76	1.5	5.5/3.1	2900	0.82	82.3	84.7	84.8	137 - 66	20 - 60
HPP 90/10	2.61	2.2	7.8/4.5	2890	0.84	85.7	86.8	86.2	135 - 54	30 - 80
HPP 90/12	2.61	2.2	7.8/4.5	2890	0.84	85.7	86.8	86.2	130 - 32	40 - 100

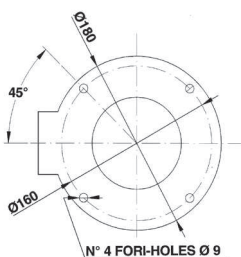
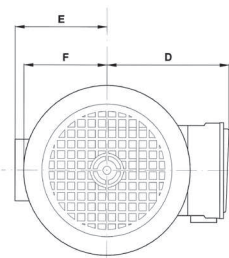
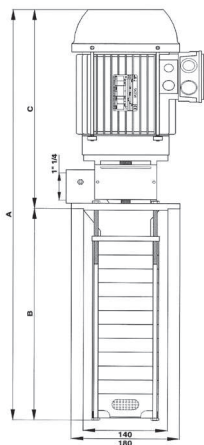

Hydraulic performance curves

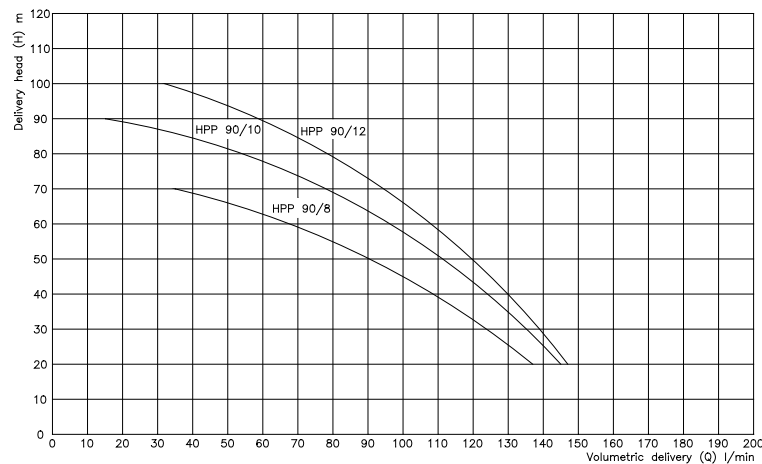

Hydraulic performance table

Type of pump	Volumetric delivery (Q) l/min ↓										
	20	30	40	50	60	70	80	90	100	110	120
HPP 90/8	137	123	108	90	66	35					
HPP 90/10	145	135	125	111	98	78	54	15			
HPP 90/12	147	140	130	116	112	95	79	57	32		

Vertical multistage pumps

Type HPP 100



Main applications

The pump is designed for pumping clean and non-explosive liquids without abrasive and filamentous suspended parts and with a viscosity not exceeding 20mm²/s.

The pump is designed for industrial applications:

- Machine tools (grinding, lathes, drilling centres)
- Glass processing machinery
- Filtration systems
- Cooling systems
- Washing machines

Operating conditions

Liquid temperature from -15 ° C to + 90 ° C - Maximum room temperature + 40 ° C.

Electric motor:

The pump is equipped with a closed construction engine, with external ventilation, built in accordance with IEC 60034-30-1 in efficiency class IE3 (Premium Efficiency).

Degree of protection IP 55

Size and weights table

Type of pump	A mm	B mm	C mm	D mm	E mm	F mm	Mass kg
HPP 100/14	934	516	418	144	99	97.5	34.5

Rating plate data

Type of pump	kW		V 230/400 - Hz 50						Q _{max} -Q litres/min	H-H _{max} metres
	Input (P1)	Nom. (P2)	In Amp.	n min ⁻¹	cos φ	IE3 η				
						50%	75%	100%		
HPP 100/14	3.41	3	9.8/5.7	2900	0.87	88.8	89.2	88.3	134 - 38	50 - 120

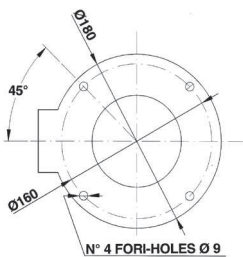
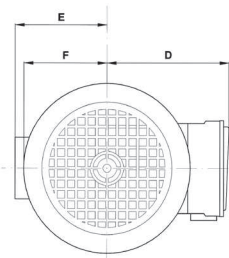
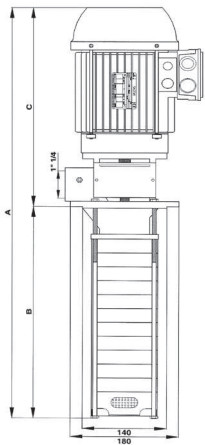

Hydraulic performance curves

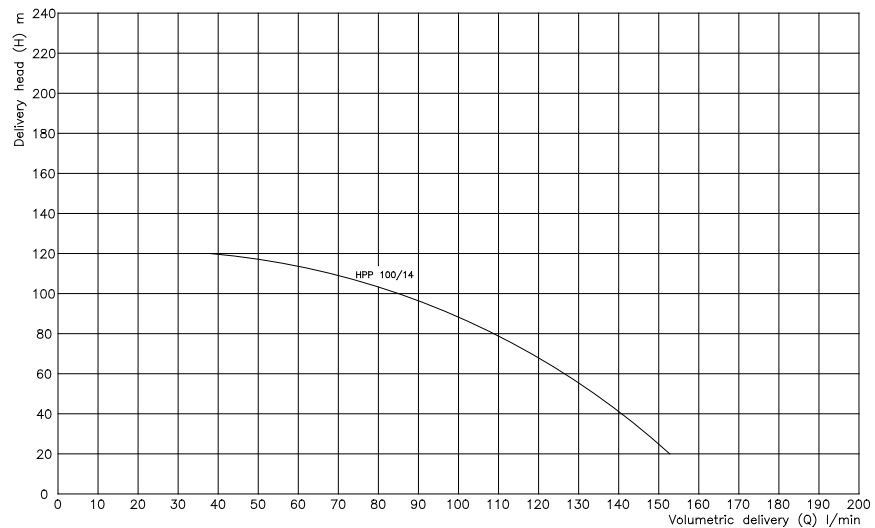

Hydraulic performance table

Delivery head (H) m	20	30	40	50	60	70	80	90	100	110	120	130	140
Type of pump	Volumetric delivery (Q) l/min ↓												
HPP 100/14	152	147	141	134	126	118	109	98	84	68	38		

Vertical multistage pumps

Type HPP 112



Main applications

The pump is designed for pumping clean and non-explosive liquids without abrasive and filamentous suspended parts and with a viscosity not exceeding 20mm²/s.

The pump is designed for industrial applications:

- Machine tools (grinding, lathes, drilling centres)
- Glass processing machinery
- Filtration systems
- cooling systems
- Washing machines

Operating conditions

Liquid temperature from -15 ° C to + 90 ° C - Maximum room temperature + 40 ° C.

Electric motor:

The pump is equipped with a closed construction engine, with external ventilation, built in accordance with IEC 60034-30-1 in efficiency class IE3 (Premium Efficiency).

Degree of protection IP 55

Size and weights table

Type of pump	A mm	B mm	C mm	D mm	E mm	F mm	Mass kg
HPP 112/16	1010	570	440	163	99	115	44.0
HPP 112/19	1091	651	440	163	99	115	45.4

Rating plate data

Type of pump	kW		V 230/400 - Hz 50						Q _{max} -Q litres/min	H-H _{max} metres
	Input (P1)	Nom. (P2)	I _n Amp.	n min ⁻¹	cos φ	IE3 η				
						50%	75%	100%		
HPP 112/16	4.43	4	12.6/7.3	2920	0.88	86.6	88.4	88.6	134 - 30	60 - 140
HPP 112/19	4.43	4	12.6/7.3	2920	0.88	86.6	88.4	88.6	130 - 25	70 - 160

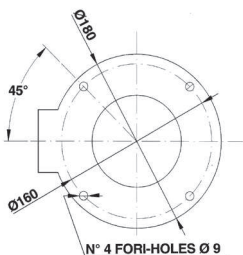
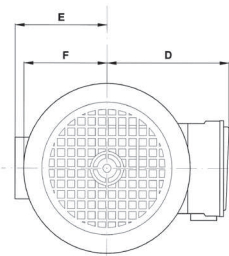
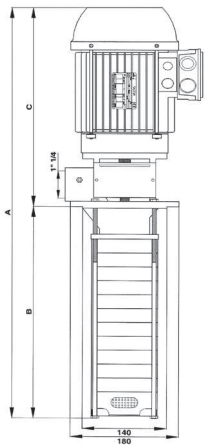

Hydraulic performance curves

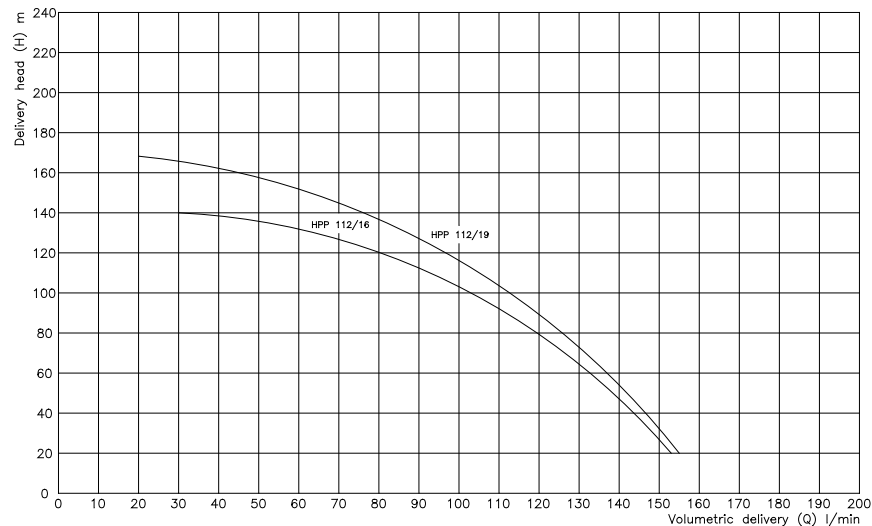

Hydraulic performance table

Delivery head (H) m	30	40	50	60	70	80	90	100	120	140	160	180
Type of pump	Volumetric delivery (Q) l/min ↓											
HPP 112/16	149	145	140	134	126	120	110	103	80	30		
HPP 112/19	151	148	142	136	132	125	119	113	99	78	43	

Use and maintenance

OPERATION AND MAINTENANCE MANUAL (ORIGINAL INSTRUCTIONS) - MOTOR-DRIVEN PUMPS *SACEMI**GENERAL INFORMATION**

This manual is designed to provide a general understanding of the machine and the instructions necessary for its proper installation and operation.

The manual is an integral part of the machine and must be read carefully before handling, installing and operating the machine and it must be kept for future reference.

Non-observance of the instructions in this manual, any improper use, any maintenance not carried out by specialised personnel, removal of labels and warnings of any kind, removal or tampering of protective guards and/or safety devices and any other action not expressly envisaged which may modify the solutions adopted by the Manufacturer concerning the safety of the machine or of its parts, can cause serious injury to persons and property and will relieve the Manufacturer of any responsibility. Any intervention on the machine by unauthorised personnel will result in the automatic termination of the product warranty.

The product identification number (Type) and its characteristics and a code for traceability of the date and batch of production are stamped on the nameplate of the motor-driven pump: the model information and warnings contained in this manual refer to the identifiable marks written on the nameplate.

As regards any situations not covered by this manual or any further information, please refer to our general catalogue and to the documentation available on www.sacemi.com and if required contact our commercial service

DECLARATION OF CONFORMITY:

The motor-driven pumps *SACEMI type AP-AU-EPC-HPP-IMM-MP-MPC-MSPV-PPI-SP-SPV-SQ-TR comply with the requirements of Directives 2006/42/EC (Machinery) - 2006/95/EC (Low Voltage) - and - 2004/108/EC (CEM). They bear the conformity marking on the plate . Some catalogue versions and products meet the requirements laid down in EN 12157 Coolant pump units for machine tools - Nominal flow rate, dimensions (see tables at the end of the manual)

PRODUCT DESCRIPTION:

Motor-driven centrifugal pumps *SACEMI are designed for the circulation of liquids in general and of cooling mixtures, according to the specific uses indicated in the tables that end this manual. The impellers are fastened directly to the extended crankshaft

The pump is equipped with a 2-pole electric motor, designed for continuous service and power supply, built according to IEC60034, cooled with external ventilation, class F winding and IP 55 protection rating.

WARNING MAINTENANCE / STORAGE OF THE MACHINE:

Temporary storage of the machine must be carried out inside its original packing, carefully placing the package in a stable position, in a clean and weather-protected environment which can protect the pump from foreign bodies accessing and from weathering (rain, snow, etc.) that may cause damage to its electrical parts.
The storage environment temperature must be between -20 ° C and +50 ° C.

 **HANDLING:**

Motor-driven pumps must be handled with the utmost care and with means appropriate to their size and weight (**which can be detected from the plate on the machine or from the table at the end of the manual**). **In particular, packed pumps must be moved in accordance with the instructions on the package**, in particular avoiding standing elongated containers on their smaller side in order to avoid any roll-over of the package. During handling and transport, be careful not to damage the delicate parts. When handling non-packed pumps listed in the catalogue other than AU-TR-SQ, only harness or pick up the machinery at its gripping points using suitable hooks or ropes. While handling the pumps there is a risk of injury; therefore, it is necessary to use suitable lifting devices appropriate to the weight and size of the pump together with personal protection equipment. The handling of the pump by lifting means must always take place slowly, with no uncontrolled oscillations in order to avoid unbalance and slippage. **DO NOT** pick up or harness the pump near the shaft: it could be damaged. **DO NOT** place the pump on the ground by leaning it on the impeller's base as it may overturn. When resting it on the ground temporarily, the pump must be placed horizontally, ensuring that thickening elements are placed under its ends to prevent it from tilting against the flange support or from rolling thereby damaging the housing of the electrical wiring terminal boards. Models AU-TR-SQ must be lifted by using a harness around the narrow neck-shaped groove between the motor body and the pump and their temporary resting on the ground must be positioned: AU pumps on their supporting tapered ring, TR-SQ ones with their motor axis horizontal, ensuring thickening elements are placed under the ends to prevent it from tilting against the flange support or from rolling thereby damaging the housing of the electrical wiring terminal boards. **DO NOT** place the pump temporarily on the ground at its engine crank rear end. When handling, every care must be taken to prevent foreign bodies from entering through the engine ventilation grilles, the suction holes and the pump delivery holes.

WARNING USE:

Motor-driven pumps *SACEMI are particularly used in the industrial field on machine tools for machining metal, plastic, glass, stones (cutting, drilling, milling, grinding, turning) and industrial applications for filtration, fluid temperature control, spray booths, surface treatment, printing machines.
The expected application for each model is specified in **table no 3**.

 **WARNING LIMITATIONS OF USE:**

Motor-driven pumps must NOT be used in explosive and / or potentially explosive environments and must NOT be used with flammable liquids or which produce harmful and/or explosive gases. For possible uses with aggressive liquids (e.g. acids, alkali solutions) please refer to the indications given for each type of pump in our Catalogue or on our website www.sacemi.com

Pumps **must NOT** be used for heads below the lowest point of the characteristic curve shown in the catalogue as the use of the pump for heads lower than these may overload the motor. Motor-driven pumps **must NOT** be used in tanks under pressure and the installer is therefore responsible for providing the necessary technical arrangements to prevent the tank from being, even temporarily, pressurised. The pumped liquid **must NOT** exceed a viscosity of 21 cSt (3°E) and a temperature of 70°C. CSA / UL certified pumps are approved for liquid at a temperature of 30 °C / 60 °C for UL and CSA respectively. The maximum permissible sizes of the solid parts allowed in the pumped fluid vary for each type of pump as indicated in the tables at the end of the manual.

The motor-driven pump is built to be installed in an indoor environment or in areas protected from the weather.

The electrical data indicated on the plate must be observed for continuous service work.

 **WARNING INSTALLATION:**

To lift the pump, use equipment and accessories as indicated in the "Handling" section.

To avoid leakage and ensure the maximum flow, please use pipes with diameters equal to the pump delivery hole.

DO NOT use rigid couplings between pump delivery and plant (except for the envisaged types).

Ensure the pump is perfectly primed before turning it on.

Ensure there are no obstructions preventing the normal cooling air flow to the engine fan.

Motor-driven pumps must be secured to avoid vibrations or movements which could damage the piping.

DO NOT insert your fingers in the intake duct for any reason as there is a risk of injury by touching the impeller.

The installer is responsible for making sure that all technical and plant precautions are put into place and maintained in the specific installation in order to ensure that the mechanical and hydraulic requirements listed below for each type are complied with.

AU Type Pumps:

The pump must be installed on the top of the tank and secured with appropriate bolts / screws. For proper operation of the pump and to ensure its correct sealing, the pump must be primed before use; the priming operation must be repeated whenever the pump sucks air due to a lack of liquid.

The pump must NOT run in the absence of liquid.

SQ Type Pumps:

The SQ type pump must be installed on a side wall of the tank.

The pump must be secured to the tank with appropriate screws, placing a seal between the tank surface and the suction inlet of the pump.

The pump must NOT run in the absence of liquid.

For proper operation of the pump and to ensure its correct sealing, it is essential to comply with the minimum level of liquid in the tank. (table no 2)

TR Type Pumps:

To ensure greater stability to the TR type pump, use rigid suction and delivery pipes.

The pump must NOT run in the absence of liquid.

For proper operation of the pump and to ensure its correct sealing, it is essential that the machinery is positioned under a constant head. (table no 2)

AP-EPC-HPP-IMM-MP-MPC-MSPV-PPI-SP-SPV type pumps:

The pump must be installed by fixing the coupling flange to the top of the tank and the pump body immersed in the liquid.

Use the appropriate screws to anchor the flange to the tank.

The maximum liquid level in the tank must always be 3-4 cm below the support flange, while the minimum level must always be above the suction chamber. The suction hole is located on the bottom of the pump body. The minimum distance between the intake hole and the bottom of the tank must be calculated in order to avoid cavitation and to prevent impurities from leaking into the fluid flow.

When installing pumps with a plastic body, please:

- Do NOT use rigid fittings and / or conical threaded connections;
- only use liquid or very thin sealants (film);
- be careful when screwing the coupling to the pump delivery, not to force it beyond the stop positioned inside the pipe coupling and, in any case, not to apply a clamping force above 40 kgm (390 Nm)

Failure to observe these warnings can irreparably damage the pump delivery hole.



WIRING:

The motor-driven pump is designed for a permanent electrical connection other than a plug.

The wiring must be carried out by qualified personnel, in accordance with the regulations in force in the country of use and must always provide for the grounding of the machine.

The motor voltage and frequency must comply with those indicated on the rating plate.

The arrangement of the connecting bridges "Y or Δ" must correspond to the wiring diagram inside the terminal board cover.

Check that the direction of rotation of the pump is the one indicated by the arrow on the pump body. Should the rotation direction be incorrect, stop the motor, disconnect the power line and reverse two phases of the power supply. Always check that the current absorbed by the pump during operation is never higher than the rating indicated on the plate.

We recommend the use of cables and plugs with the appropriate section for the currents absorbed by the electric motor that equips the machine; please remember that the absorbed current when turning the pump on can be much higher than those indicated on the plate.

As the standard construction of the motor-driven pump does not include any overload protection, the installer must provide a separate and adequate protection.

Make sure that fuses, circuit breakers and thermal relays are properly dimensioned.

Direction of rotation of the motor:

As regards AP-AU-EPC-IMM-MP-MPC-MSPV-PPI-SP-SPV-SQ-TR pumps, if you look at the motor's fan cover from above, the cooling fan must turn to the right (clockwise).

As regards HPP pumps, if you look at the motor's fan cover from above, the cooling fan must turn to the left (anticlockwise).



WARNING

INSTRUCTIONS FOR USE:

The machine must always be positioned with the motor axis in a vertical position in order to work correctly. The working environment temperature must be between -20 ° C and +40 ° C.

Although the pumps are designed to tolerate the presence of impurities contained in liquids (with the quantities indicated in table no 1), it is still recommended to prepare appropriate decanting zones (e.g. dividing the tank into compartments), in compliance with the installation rules. As regards self-priming pumps, an initial trigger must be provided by filling the suction or delivery pipe.

Should there be a leakage of liquid from the inlet of the axle into the suction / discharge chamber in pumps equipped with a mechanical seal, stop the machine and check the damaged part. In the event of electrical failure on a machine equipped with a single-phase motor, the operator must pay attention to possible electrostatic phenomena due to the capacitor.

The outer casing of the motor can reach 70°C; thus, it is advisable, for prolonged operations on this surface, to use appropriate protections (gloves).

For the Lp acoustic pressure level see table no 1.

WARNING

MAINTENANCE:

The pump does not require any special scheduled maintenance work in addition to the necessary periodic cleaning of the impeller and of the feed screw from the impurities present in the liquid.

To replace bearings, mechanical seals and/or components of the electric motor, refer to the technical data sheets in our general catalogue and to the documentation available on the website www.sacemi.com or contact our commercial service.

All maintenance operations must be carried out by qualified personnel, with the machine not running and disconnected from the mains.



DECOMMISSIONING OF THE MACHINE AND WASTE DISPOSAL:

The decommissioning of the motor-driven pump must be carried out by competent personnel who must safely remove the electrical, hydraulic and mechanical connections in that order, making the installation completely inoperative and secure (e.g. protect/close the lights in the empty tank). Finally, dismantling must be carried out in appropriate structures, in full compliance with the applicable laws of the user's country concerning waste disposal and separate collection, bearing in mind the materials forming the pump as detailed in table no 1.

Symbols used / terminology

	Warning		General danger		Electrical shock hazard
It warns that failure to comply with the prescriptions involves a risk of damage to the machine		It warns that non-observance entails a risk of harming people and/or things		It warns of the presence of high voltage with the risk of electric shock	

Table no 1 **Technical features**

Type of pump	Main components	Impurities allowed mm	Weight kg		Lp (db)
			Range		
AP 80B	Steel - Aluminium - Cast Iron - Plastics - Copper - Paints	≤2	37	48	<70
AP 90A	Steel - Aluminium - Cast Iron - Plastics - Copper - Paints	≤2	41	51	73
AP 90B	Steel - Aluminium - Cast Iron - Plastics - Copper - Paints	≤2	43	53	75
AP 100A	Steel - Aluminium - Cast Iron - Plastics - Copper - Paints	≤2	48	58	78
AP 112B	Steel - Aluminium - Cast Iron - Plastics - Copper - Paints	≤2	59	71	76
AU	Steel - Aluminium - Cast Iron - Plastics - Brass - Copper - Paints	≤ 0.03	4	6	<70
EPC 63-71-80	Steel - Aluminium - Cast Iron - Plastics - Brass - Copper - Paints	≤ 0.03	8	18	<70
EPC 90	Steel - Aluminium - Cast Iron - Plastics - Brass - Copper - Paints	≤ 0.03	30	32	<70
PPI 63-71	Steel - Aluminium - Plastics - Brass - Copper - Paints	≤ 0.03	9	12	<70
HPP 80	Steel - Aluminium - Cast Iron - Plastics - Copper - Paints	≤ 1	15	21	<70
HPP 90	Steel - Aluminium - Cast Iron - Plastics - Copper - Paints	≤ 1	25	30	<70
HPP 100-112	Steel - Aluminium - Cast Iron - Plastics - Copper - Paints	≤ 1	34	46	78
IMM 40-50	Steel - Aluminium - Plastics - Copper - Paints	≤ 3	1	2	<70
IMM 63	Steel - Aluminium - Plastics - Copper - Paints	≤ 3	5	6	<70
IMM 71	Steel - Aluminium - Plastics - Brass - Copper - Paints	≤ 3	9	12	<70
IMM 80	Steel - Aluminium - Plastics - Brass - Copper - Paints	≤ 3	14	19	<70
IMM 90A	Steel - Aluminium - Cast Iron - Plastics - Copper - Paints	≤ 4	47	50	73
IMM 90 B	Steel - Aluminium - Cast Iron - Plastics - Copper - Paints	≤ 4	49	52	75
IMM 100	Steel - Aluminium - Cast Iron - Plastics - Copper - Paints	≤ 4	53	56	78
MP 63-71	Steel - Aluminium - Plastics - Brass - Copper - Paints	≤ 3	6	11	<70
MP 80-90	Steel - Aluminium - Plastics - Brass - Copper - Paints	≤ 3	16	24	<70
MP 100	Steel - Aluminium - Plastics - Brass - Copper - Paints	≤ 3	32	36	<70
MPC 80	Steel - Aluminium - Plastics - Brass - Copper - Paints	≤2	15	19	<70
MPC 90	Steel - Aluminium - Plastics - Brass - Copper - Paints	≤2	25	29	<70
MPC 100	Steel - Aluminium - Plastics - Brass - Copper - Paints	≤2	38	43	<70
MSPV 71-80	Steel - Aluminium - Plastics - Copper - Paints	≤ 3	9	14	<70
SP 12-18-25-33	Steel - Aluminium - Cast Iron - Plastics - Copper - Paints	≤ 3	5	9	<70
SP 50-75-100-150	Steel - Aluminium - Cast Iron - Plastics - Copper - Paints	≤ 3	13	22	<70
SPV 12-18-25-33	Steel - Aluminium - Plastics - Copper - Paints	≤ 3	2	6	<70
SPV 50-75-100-150	Steel - Aluminium - Plastics - Copper - Paints	≤ 3	7	15	<70
SQ	Steel - Aluminium - Plastics - Cast Iron - Brass - Copper - Paints	≤ 3	3	18	<70
TR	Steel - Aluminium - Plastics - Cast Iron - Brass - Copper - Paints	≤ 3	12	15	<70
HPP 80	Steel - Aluminium - Plastics - Cast Iron - Copper - Paints	0	15	21	<70
HPP 90	Steel - Aluminium - Plastics - Cast Iron - Copper - Paints	0	25	30	<70
HPP 100	Steel - Aluminium - Plastics - Cast Iron - Copper - Paints	0	30		<70
HPP 112	Steel - Aluminium - Plastics - Cast Iron - Copper - Paints	0	44	46	<70

Table no 2 **Motor wiring**

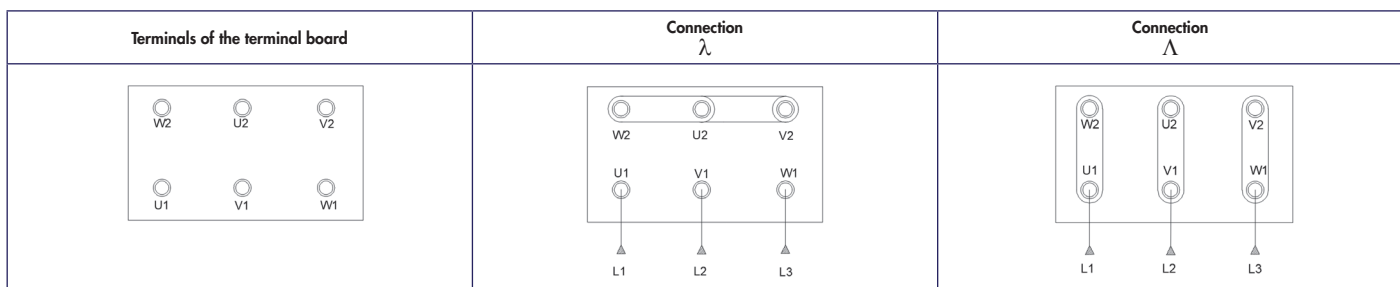

Table no 3	Table showing possible uses
-------------------	------------------------------------

Type	Uses	Type of fluid
IMM 40	Cutting - drilling	Oil-oily emulsions
IMM 50 A	Cutting - drilling - milling - conditioning	Oil-oily emulsions
IMM 63-71-80	Turning - filtration - milling - grinding - glass processing	Oil-oily emulsions
IMM 90-100	Turning - filtration - grinding - spray booths	Oil - oily emulsions - paint water
SPV 12-18	Cutting - drilling - milling - conditioning - glass processing	Oil-oily emulsions
SPV 25-33-50-75-100-150	Cutting - drilling - milling - printing - glass processing	Oil-oily emulsions - glycol
SP 12-18	Milling - turning - drilling	Oil-oily emulsions
SP 25-33-50-75-100-150	Milling - turning - drilling - grinding - filtration	Oil-oily emulsions
AU 56-63	Recirculation- suction	Oil-oily emulsions
71 - 80	Recirculation- transfer	Oil - oily emulsions - alkaline solutions
SQ 56-63-71-80	Milling - turning - drilling - surface treatment	Oil - oily emulsions - alkaline solutions
AP 80-90-100-112	Turning - filtration - grinding - surface treatment	Oil - oily emulsions - alkaline solutions
MP 63-71-80-90-100	Turning - filtration - grinding	Oil-oily emulsions
MPC 80-90-100	Turning - filtration - grinding	Oil-oily emulsions
MSPV 71-80	Cutting - drilling - milling - printing - glass processing	Oil-oily emulsions - glycol
EPC 63-71-80-90	Deep-hole-drilling-cooling	Oil-oily emulsions - glycol
PPI 63 - 71	Thermoregulation	Diathermic oil

TROUBLESHOOTING GUIDELINES

Flaw detected	Possible causes	Possible solution
The engine does not start - No noise	<ul style="list-style-type: none"> - flaw in motor terminal box connections - flaw in the power supply wiring 	<ul style="list-style-type: none"> - Check the motor terminal board connections - Check the power line - Check all switches, fuses and thermal protectors
The engine does not start - Humming perception	<ul style="list-style-type: none"> - motor failure due to no winding - power line flaw due to phase failure - blocked impeller - blocked bearing - blocked bushing - blocked seal 	<ul style="list-style-type: none"> - Check the motor terminal board connections - Check motor winding - Check the power line - Replace the impeller - Replace bearing - Replace bushing - Replace seal
The motor runs, but there is no liquid flowing	<ul style="list-style-type: none"> - the liquid level in the tank is below the minimum required - the impeller is damaged and/or occluded - suction hole occluded - delivery pipe is closed 	<ul style="list-style-type: none"> - Top up the minimum level of liquid in the tank - Clean the impeller and replace it if damaged - Clean suction hole - Clean the suction and pumping chamber - Clean the delivery pipe
Insufficient pressure and flow	<ul style="list-style-type: none"> - wrong motor rotation direction - impeller, suction chamber, delivery pipe clogged with impurities - the impeller is damaged - suction chamber, pumping chamber are damaged 	<ul style="list-style-type: none"> - Restore the correct rotation direction of the motor - Clean the impeller, the suction chamber and delivery pipe - Replace the impeller - Replace the delivery pipe, the suction and pumping chambers
Motor power absorption is too high	<ul style="list-style-type: none"> - too many impurities - friction between moving parts - liquid density beyond the limits of use 	<ul style="list-style-type: none"> - Remove impurities other than those allowed - Identify and replace defective components - Restore liquid density within the limits of use



CUL/US ADDITIONAL INFORMATION

WARNINGS:

- The installer must provide motor protection against overloads.
- The installer must protect the pump to avoid it being used with no liquid.
- **Electric shock hazard** – This pump has not been evaluated for use in swimming pools and / or equivalent environments.
- Motors designed for dual voltage operation indicate the electrical data for which they have been factory-set.

CAUTION:

- These pumps have been evaluated only to be used with water.

Our foreign partners

AUSTRIA

MOLL MOTOR MECHATR. ANTRIEBSTECHNIK GMBH
Industriestrasse 8 - 02000 Stockerau
Tel. +43-226663421 - Fax +43-22666342180
hannes.lehner@mollmotor.at

BELGIUM

NV GERMOND
Lodewijk De Raetlaan 59 - 08870 Izegem
Tel. +32-51310672 - Fax +32-51312169
info@germond.be

CHINA

SHENZHEN ROSIT TECHNOLOGY CO.,LTD
Room A1404,14/F Ta.B3 Longgang Tianan Clongcheng Str.-Shenzhen
Tel/Fax +86-07558378937
816@noxde.com

CZECH REPUBLIC

MACH TRADE S.R.O.
Podnikatelska 565/10A - Praha 9 - Bechovice
Tel. +42-0603293270 Fax +42-0272661599
kovalik@machtrade.cz

DENMARK

ELTECO APS
Valloevvej 3 - 07400 Herning
Tel. +45-70251845 Fax +45-70251855
info@elteco.dk

FINLAND

TEKNOPUMP OY
Kaukoilantie 5B - 03100 Nummela
Tel. +38-5350800
roger.tuhkunen@teknopump.fi

FRANCE

LAMBERT MOTEURS S.A.
6 Park Le Plateau 15 Chemin Du Plateau - 69570 Dardilly
Tel. +33-478668950 Fax +33-472291386
g.flavien@lambertmoteurs.com

GERMANY

CALPEDA PUMPEN VERTRIEB GMBH
Philipp-Reis Strasse 2 - 63755 Alzenau
Tel. +49-602396433 Fax +49-6023964333
verkauf@calpeda.de

HOLLAND

TECHNISCH BUREAU UNICUM
Prinsenweide, 30 - 07317 Bb Apeldoorn
Tel. +31-555221433 Fax +31-555223931
info@pauljulien.nl

IRELAND

HOUGHTON PLC
76C Dunboyne Ind.Est.
Dunboyne Co.Meath - Tel. +35-318255755
tomas.moriarty@houghtonintl.com

ISRAEL

MORDECHAI AMITY TECHNICAL
P.O. Box 2323 - 8 Jaffo Rd - 10000 Tel Aviv
Tel. +97-236823247 Fax +97-236826533
amityltd@zahav.net.il

NORTH AMERICA

LAFERT N.A. (NORTH AMERICA)
5620 Kennedy Rd. - L4z 2A9 Mississauga, On
Tel. +1-905629193 Fax +1-9056292852
dbolanos@lafertna.com

POLAND

ZAKLAD HANDLOWO USLUGOWY
Ul. Jeziorna, 15 - 48300 NYSA
Tel. +48-774093930 Fax +48-774310543
info@hasan.pl

PORTUGAL

FTBL-MAQUINAS EQUIPAMENTOS LDA
Rua Soares Dos Reis 1324 - 4430-240 Mafamude Vng
Tel. +35 1227835285 Fax +35-1227830932
ftblportugal@hotmail.com

RUSSIA

SVS HYDRALICS LTD
Petrovsko-Razumovsky 4-29 - 127287 Moscow
Tel. +7-4956148209 Fax +7-4956148068
saws@svs-saws.ru

SLOVENIA

CIZMAN D.O.O.
Plocanska Ulica 019 - 1000 Ljubljana Smartno
Tel. +38-641640009 Fax +38-615110022
info@crpalke-cizman.si

SPAIN

PROINDECSA 2015, S.L.
Oeste Parc,25/12-Polg.Industr. - 30169 San Gines - Murcia
Tel. +34-968880852 - Fax +34-968880984
proindecsa@proindecsa.com

SWEDEN

BUSCK & CO. AB.
Gamla Riksvagen 14 - 42832 Kallered
Tel. +46-31870900 Fax +46-31872712
info@busck.se

SWITZERLAND

ELECTRO MUELLER AG/SA
Boezingenstrasse 37 - 02500 Biel-Bienne 4
Tel. +41-323441010 Fax +41-323441019
m.ott@electro-mueller.ch

UNITED KINGDOM

PUMPS & EQUIPMENT (WARWICK)LTD
6 Collins Road - Warwick Cv346ff
Tel. +44-192645174 Fax +44-1926451284
mike@pumps-equip.co.uk

Notes

It is forbidden to reproduce any part of this document in any form without the explicit written consent of *SACEMI-GAMAR S.r.l.*

The data in this catalogue are indicative and non-binding. ***SACEMI-GAMAR S.r.l.*** reserves the right to modify the indications at any time without notice, according to the technical development of the product.
This catalogue supersedes and replaces all previous ones.

SACEMI GAMAR SRL

Via A. Pacinotti n. 2 - 30020 Noventa di Piave (VE) Italy
T +39 0421 307389 - F +39 0421 65428
info@sacemi.com - www.sacemi.com