



ENAPART



93 S Railroad Avenue Unit C
Bergenfield NJ 07621 USA
www.enapart.com
sales@enapart.com



Friedrich-Fhert-Anlage 36_60325



〒584-0023 大阪府富田林市若松町
東2丁目2番16号
www.enapart.co.jp
sales@enapart.co.jp



Via del Canneto 35,
Borgosatollo, Brescia - Italia
www.enapart.it
vendite@enapart.it



4 boulevard Carnot, 95400
villiers-le-bel, Paris, France
www.enapart.fr
sales@enapart.fr



PLAZA NUESTRA SEÑORA DE LAS
NIEVES 12 ,LOCAL ,50012,ZARAGOZA
www.enapart.es
ventas@enapart.es



Barbaros Mah. Ihlamur Bul. Ağaoğlu
My Newwork No:3/15 Ataşehir / İstanbul
www.enapart.net
satis@enapart.net



65049, ОДЕСА, ВУЛИЦЯ ІВАНА
ФРАНКА, БУДИНОК 55, ПОВЕРХ 3
www.enapart.com.ua
sales@enapart.com.ua



Складова база „Онгъл“, Склад А2, п.к.
4006, гр. Пловдив, България
www.enapart.bg
sales@enapart.bg



PRIVADA 10 B SUR #3908 COL.
ANZUREZ, C.P. 72530, PUEBLA,PUE
www.enapart.com.mx
sales@enapart.com.mx



MUNICIPIUL BUCUREȘTI, SECTOR 3,
B-DUL BASARABIA, NR.250, CORP P+5
www.enapart.ro
sales@enapart.ro



3 Austin Mews, High Street, Hemel
Hempstead, HP1 3AF , United Kingdom
www.enapart.co.uk
sales@enapart.co.uk

Locking Assembly dimensions											Transmissible torques or axial forces						Weight			
d x D	d	C ₁	C _b	D	C ₂	L	I	At	F ₀	FA'	T	F _{ax}	X				WT	d ₁	D ₁	T _{max}
mm	Inch								psi	lb-ft	lbs	Inch				lbs 10 ⁻³	Inch		lb-ft	
260 x 290	10.236			11.417		1.890	1.732	55.955	40917	438399	41676	97797	0.276	0.394	0.512	0.630	10584	10.268	11.386	87249
270 x 300	10.630			11.811	-0	1.890	1.732	58.125	39793	456385	44996	101169	0.276	0.394	0.512	0.630	10805	10.661	11.780	94157
280 x 313	11.024	+0	-0	12.323	+0.0032	2.087	1.929	66.805	46313	523831	53479	116906	0.276	0.433	0.551	0.669	13892	11.055	12.291	111663
290 x 323	11.417			12.717		2.087	1.929	69.130	49910	541817	57167	120279	0.276	0.433	0.551	0.669	14333	11.449	12.685	119337
300 x 333	11.811			13.110		2.087	1.929	71.610	48112	559802	61224	124775	0.276	0.433	0.551	0.669	14774	11.843	13.079	127854
320 x 360	12.598			14.173	-0	2.559	2.323	91.915	65647	719424	84090	159622	0.394	0.591	0.787	0.984	24035	12.638	14.134	177231
340 x 380	13.386			14.961	+0.0035	2.559	2.323	97.650	61151	764388	94786	169739	0.394	0.591	0.787	0.984	25358	13.425	14.921	200420
360 x 400	14.173	+0	-0	15.748	+0.0035	2.559	2.323	103.385	58004	809353	106219	179856	0.394	0.591	0.787	0.984	26901	14.213	15.709	224858
380 x 420	14.961	-0.0035	+0.0035	16.535		2.559	2.323	109.120	60477	854317	118390	189973	0.394	0.591	0.787	0.984	28224	15.000	16.496	249923
400 x 440	15.748			17.323	-0	2.559	2.323	115.010	57554	899281	131299	200090	0.394	0.591	0.787	0.984	29768	15.787	17.283	277097
420 x 460	16.535	+0	-0	18.110	+0.0038	2.559	2.323	120.590	54856	944245	144576	210207	0.394	0.591	0.787	0.984	31091	16.575	18.071	305640
440 x 480	17.323	-0.0038	+0.0038	18.898		2.559	2.323	126.325	52608	989209	158592	220324	0.394	0.591	0.787	0.984	32414	17.362	18.858	335509

More sizes on request

■ Mounting of Locking Element

The values for T, F_{ax}, P_W and P_N apply to Locking Elements installed in oiled condition.

■ Surface finishes

For shafts and hub bores

R_a ≤ 63 RMS

Required screw tension force

for Locking Elements solid: $F_A = F_{A'} + F_0$

for Locking Elements slit: $F_A = F_{A'}$

Where n-Locking Elements are used one behind the other (series), the following applies to the increase in T and F_{ax}:

$$T_n = T_1 \cdot m \quad \text{and} \quad F_{axn} = F_{ax1} \cdot m$$

Retaining the values for T and F_{ax} it is possible to reduce F_{A'} and p where:

$$F_{A'n} = F_{A'}/m \quad \text{and} \quad p_n = p/m$$

With 2 / 3 / 4 Locking Elements, m = 1.555 / 1.86 / 2.03

For tolerances see table on 39/41.

The fits specified have given excellent service in practical operations. Naturally, the shafts and the bores can feature other clearances. Please contact our Technical Department.

1) approx. values

■ Undercut, clearance cut

The relatively narrow RINGFEDER® RfN 8006 Locking Elements mainly serve the purpose of transmitting large torques and axial forces. They are not self-centering. The concentricity accuracy of the clamped hub therefore depends on the centering and care with which installation is carried out. Locking Elements RfN 8006 can center themselves within the framework of their production accuracy if they are absolutely plane-parallel when pressed together.

Explanations to tables

d, D, L, l = Basic dimensions, Locking Elements not tightened

C_1 = shaft tolerances

C_b = hub bore tolerances

C_2 = bore tolerances

A_t = effective bearing surface $A_t = \pi \cdot d \cdot l$

X = travel distance for 1,2,3 or 4 Locking Elements. This value includes a safety allowance to ensure that the thrust flange will not contact the face of the hub or shaft. Any reduction of this value could cause a block and the transmission values of the connection would not be achieved.

T = transmissible torque

F_{ax} = axial forces

T and F_{ax} refer to a pressure between the Locking Element and shaft of 14500 psi .

When solid Locking Elements the required total clamping force F_A is obtained by:

$$F_A = F_{A'} + F_O$$

$F_{A'}$ = Screw number x Fv, see screw table page 40

F_O = approximate clamping force required to bridge the clearances where the tolerances given in the table are fully exploited during manufacture, not applicable if slit Locking Elements are used.

d_1 = clamp plate bore

D_1 = spacer sleeve OD

T_{max} = transmissible torque by one Locking Element at a shaft contact pressure of = 47850 psi

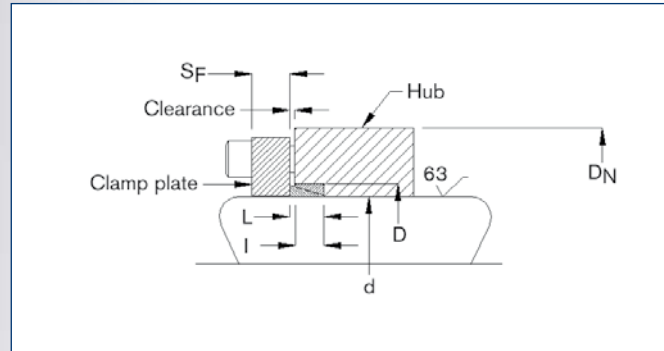

Hub bolted Clamp Plate (hub axially adjustable)

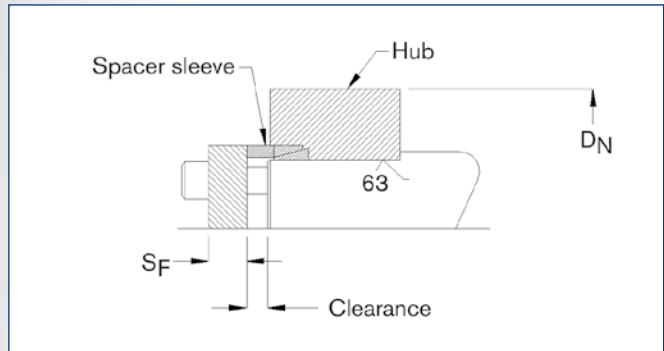

Shaft bolted Clamp Plate (hub axially fixed)

Explanations

- d = shaft diameter
- C_1 = machining tolerances for shaft (d)
- D = counter bore diameter
- C_2 = machining tolerances for counter bore (D)
- L, I = width dimensions, relaxed condition
- R = radius in hub bore
- F_O = preload to bridge specified fit clearances
- F_A = actual locking force to generate T
- T = transmissible torque for one Locking Element
based on coefficient of friction of $\mu = 0.15$ and
10,000 psi contact pressure
(torque can be increased by up to 50%)
- F_{ax} = axial load (thrust capacity)
- D_N = Hub outer diameter
- S_F = Clamp plate thickness

Size	GSA dimensions						F _o	F _A '	Transmissible torques or axial forces		Weight WT
	d	C ₁	D	C ₂	L	I			T	F _{ax}	
	Inch								psi	lb-in	
GSA-250	0.2500		0.3750		0.126	0.094	580	450	14	112	0.76
GSA-312	0.3125	+0	0.4375	-0	0.143	0.112	686	670	26	166	1.04
GSA-375	0.3750	-0.0005	0.5000	+0.0005	0.160	0.128	673	920	43	229	1.35
GSA-437	0.4375		0.5937		0.176	0.143	796	1196	65	297	2.20
GSA-500	0.5000		0.6562		0.193	0.158	944	1512	94	376	2.69
GSA-562	0.5625		0.7500	-0	0.210	0.174	1259	1872	132	469	3.97
GSA-625	0.6250		0.8125	+0.001	0.226	0.187	1231	2237	175	560	4.69
GSA-687	0.6875		0.8750		0.243	0.203	1414	2670	230	669	5.47
GSA-750	0.7500	+0	0.9375		0.260	0.219	1413	3145	295	787	6.33
GSA-812	0.8125	-0.001	1.0312		0.276	0.234	1617	3637	370	911	8.56
GSA-875	0.8750		1.0937	-0	0.293	0.250	1611	4188	458	1047	10.14
GSA-937	0.9375		1.1875	+0.0015	0.310	0.267	2087	4790	561	1197	12.36
GSA-1000	1.0000		1.2500		0.326	0.284	2090	5437	680	1360	14.05
GSA-1125	1.1250	+0	1.4060		0.359	0.312	2220	6620	840	1493	19.55
GSA-1250	1.2500	-0.0015	1.5310		0.393	0.344	2240	8105	1140	1824	23.54
GSA-1375	1.3750		1.6870		0.426	0.376	2745	9750	1510	2196	31.22
GSA-1500	1.5000		1.8120	-0	0.459	0.407	3030	11510	1940	2587	36.38
GSA-1625	1.6250	+0	1.9680	+0.002	0.492	0.437	3295	13390	2450	3015	46.43
GSA-1750	1.7500	-0.002	2.1250		0.526	0.469	3585	15475	3045	3480	58.53
GSA-1875	1.8750		2.2500		0.559	0.500	3595	17675	3730	3979	66.22
GSA-2000	2.0000		2.4060		0.592	0.528	5365	19910	4480	4480	81.09
GSA-2250	2.2500		2.6560		0.592	0.528	4795	22400	5670	5040	90.30
GSA-2437	2.4375		2.8430		0.592	0.528	4430	24260	6655	5461	97.07
GSA-2500	2.5000	+0	2.9060	-0	0.592	0.528	4330	24885	7000	5600	99.50
GSA-2687	2.6875	-0.003	3.0930	+0.003	0.592	0.528	4035	26750	8090	6020	106.26
GSA-2750	2.7500		3.1560		0.592	0.528	3950	27370	8470	6160	108.70
GSA-3000	3.0000		3.4060		0.592	0.528	3890	29860	10080	6720	117.90

* Stainless steel available upon request.

* Delivery on request; other sizes stocked. Contact Ringfeder Corporation for additional sizes and information.

■ Selection Guide

1. Determine the shaft diameter to be used and the maximum torque (T) to be transmitted.

$$T = \frac{63,000 \text{ (lb-in)} \times \text{HP}}{\text{RPM}}$$

2. Select a locking element from the specification table for the shaft diameter. Verify that the transmissible torque (T) for the element meets the torque requirement.

Note: Required peak torque should never exceed specified transmissible torque (T). Higher torque capacities can be obtained by increasing the locking force.

3. Determine the required locking force (F_A'). A pre-load (F_O) is required to bridge the clearance for the specified fits. The total required locking force is F_A' = F_O + F_A'. The locking force is normally obtained by using one or more screws and a clamp plate.

4. Refer to screw tables on page 40 to determine the number, size and grade of screws needed for the required locking force and individual screw clamp load.

$$\text{Clamp load/screw} = \frac{\text{required locking force (F}_{A}'\text{) or F}_{A}'\text{'}}{\text{number of screws (z)}}$$

Explanations to tables

d, D, L, l = Basic dimensions, Locking Elements not tightened

C_1 = shaft tolerances

C_b = hub bore tolerances

C_2 = bore tolerances

A_t = effective bearing surface $A_t = \pi \cdot d \cdot l$

X = travel distance for 1,2,3 or 4 Locking Elements. This value includes a safety allowance to ensure that the thrust flange will not contact the face of the hub or shaft. Any reduction of this value could cause a block and the transmission values of the connection would not be achieved.

T = transmissible torque

F_{ax} = axial forces

T and F_{ax} refer to a pressure between the Locking Element and shaft of 14500 psi .

When solid Locking Elements the required total clamping force F_A is obtained by:

$$F_A = F_{A'} + F_O$$

$F_{A'}$ = Screw number x Fv, see screw table page 40

F_O = approximate clamping force required to bridge the clearances where the tolerances given in the table are fully exploited during manufacture, not applicable if slit Locking Elements are used.

d_1 = clamp plate bore

D_1 = spacer sleeve OD

T_{max} = transmissible torque by one Locking Element at a shaft contact pressure of = 47850 psi



Weitere technische Hinweise befinden sich im jeweiligen Katalog.

Alle technischen Daten und Hinweise sind unverbindlich. Rechtsansprüche können daraus nicht abgeleitet werden. Der Anwender ist grundsätzlich verpflichtet zu prüfen, ob die dargestellten Produkte seinen Anforderungen genügen. Änderungen, die dem technischen Fortschritt dienen, behalten wir uns jederzeit vor. Mit Erscheinen dieses Kataloges werden alle älteren Prospekte und Fragebögen zu den gezeigten Produkten ungültig.

Check out the respective catalogue for further technical details

All technical details and information is non-binding and cannot be used as a basis for legal claims. The user is obligated to determine whether the represented products meet his requirements. We reserve the right at all times to carry out modifications in the interests of technical progress. Upon the issue of this catalogue all previous brochures and questionnaires on the products displayed are no longer valid.

RINGFEDER POWER TRANSMISSION GMBH

Werner-Heisenberg-Straße 18, D-64823 Groß-Umstadt, Germany · Phone: +49 (0) 6078 9385-0 · Fax: +49 (0) 6078 9385-100
E-mail: sales.international@ringfeder.com · E-mail: sales.international@gerwah.com

RINGFEDER POWER TRANSMISSION USA CORPORATION

165 Carver Avenue, P.O. Box 691 Westwood, NJ 07675, USA · Toll Free: +1 888 746-4333 · Phone: +1 201 666 3320
Fax: +1 201 664 6053 · E-mail: sales.usa@ringfeder.com · E-mail: sales.usa@gerwah.com

RINGFEDER POWER TRANSMISSION INDIA PRIVATE LIMITED

Plot No. 4, Door No. 220, Mount - Poonamallee Road, Kattupakkam, Chennai – 600 056, India
Phone: +91 (0) 44-2679-1411 · Fax: +91 (0) 44-2679-1422 · E-mail: sales.india@ringfeder.com · E-mail: sales.india@gerwah.com

KUNSHAN RINGFEDER POWER TRANSMISSION COMPANY LIMITED

German Industry Park, No. 508 Hengguanjiang Road, Zhangpu Town 215321, Kunshan City, P.R. China
Phone: +86 (0) 512-5745-3960 · Fax: +86 (0) 512-5745-3961 · E-mail sales.china@ringfeder.com