



ENAPART



93 S Railroad Avenue Unit C
Bergenfield NJ 07621 USA
www.enapart.com
sales@enapart.com



Via del Canneto 35,
Borgosatollo, Brescia - Italia
www.enapart.it
vendite@enapart.it



Barbaros Mah. Ihlamur Bul. Aĝaoĝlu
My Newwork No:3/15 Ataşehir / İstanbul
www.enapart.net
satis@enapart.net



PRIVADA 10 B SUR #3908 COL.
ANZUREZ, C.P. 72530, PUEBLA, PUE
www.enapart.com.mx
sales@enapart.com.mx



Friedrich-Ebert-Anlage 36, 60325
Frankfurt am Main, Germany
www.enapart.de
anfrage@enapart.de



4 boulevard Carnot, 95400
villiers-le-bel, Paris, France
www.enapart.fr
sales@enapart.fr



65049, ОДЕСА, ВУЛИЦЯ ІВАНА
ФРАНКА, БУДИНОК 55, ПОВЕРХ 3
www.enapart.com.ua
sales@enapart.com.ua



MUNICIPIUL BUCUREȘTI, SECTOR 3,
B-DUL BASARABIA, NR.250, CORP P+5
www.enapart.ro
sales@enapart.ro



〒584-0023 大阪府富田林市若松町
東2丁目2番16号
www.enapart.co.jp
sales@enapart.co.jp



PLAZA NUESTRA SEÑORA DE LAS
NIEVES 12 ,LOCAL ,50012,ZARAGOZA
www.enapart.es
ventas@enapart.es



Складова база „Онгъл“, Склад А2, п.к.
4006, гр. Пловдив, България
www.enapart.bg
sales@enapart.bg



3 Austin Mews, High Street, Hemel
Hempstead, HP1 3AF , United Kingdom
www.enapart.co.uk
sales@enapart.co.uk



brands you trust.



The Quarter-Turn
Actuator Experts

CRANE

www.cranecpe.com



REVO – WORLD CLASS ACTUATOR TECHNOLOGY

The Revo brand is the standard for excellence and performance in actuator technology and is widely recognised in the process industries as a leader in quality and innovation. That innovation is partnered with a manufacturing excellence to drive advances in product technology. With our combined knowledge and experience we can offer the optimum actuator for any application.



Revo actuators are primarily used for the operation of valves with 90° travel, such as ball valves, plug valves and butterfly valves, but also find applications where rotary movements of 180°, Multi-position or others are needed. Revo quarter-turn actuators can be used for open/close applications or for control service.

The range comprises standard models to suit a wide range of torque ratings and flange connections. A comprehensive line-up of specific options further extends the application capability to provide a configuration to suit almost every purpose.

On double-acting versions the valve is opened and closed by the supply of compressed air to the actuator. On single-acting actuators compressed air is applied only in one direction, movement in the opposite direction is accomplished by spring force. This offers a fail-safe function in case of a failure in the air supply.

Revo quarter-turn actuators already comply with the EN-standards, which will supersede a large proportion of the DIN-standards, as well as a variety of ISO-standard drafts and various factory standards used in large scale industry.

A COMPANY WITH GLOBAL PEDIGREE

As part Crane ChemPharma & Energy, the Revo brand belongs to a wider group that provides solutions to the diversified process industries through the development, production and distribution of actuators, valves, pumps and related flow components.



Experience counts

Crane ChemPharma & Energy, in turn, draws upon the heritage and manufacturing experience of the Crane Corporation to provide its customers with a worldwide understanding of manufacturing quality standards and legislative requirements. This, coupled

with a long established network of independent distribution partners, ensures a global network that provides the structure to design and deliver world-class products with world class service.



AUTOMATION

Automation

Intelligent automation is crucial to the efficiency and profitability of today's processing plants. Whether you're operating basic valve and actuator packages to facilitate simple "open/close" manoeuvres or running complex bus-interfaced systems as part of wider plant control, there's a Revo actuation package to suit the application.



Customisation is the Key

Nearly every application requires a different solution. Crane can offer the right actuation and control package for your specific demand. That's why at Revo, we offer a full customisation service. We can supply a single, basic actuator or a complete module consisting of actuation and accessories such as solenoids, limit switches, position and bus-system controls.



Designed for your demand

Revo provides solutions, not just products. Flexibility and fast response from initial design, through assembly, test run and inspection of all component parts enables us to provide finished product that meets your expectations. And you can rest assured in the knowledge that our Quality Assurance procedures fully comply with ISO 9001/EN 29001 operational standards.

MAIN APPLICATIONS

Revo pneumatic quarter-turn actuators provide efficient solutions for plant automation tasks. Our unique design features enable continuous trouble-free operation.

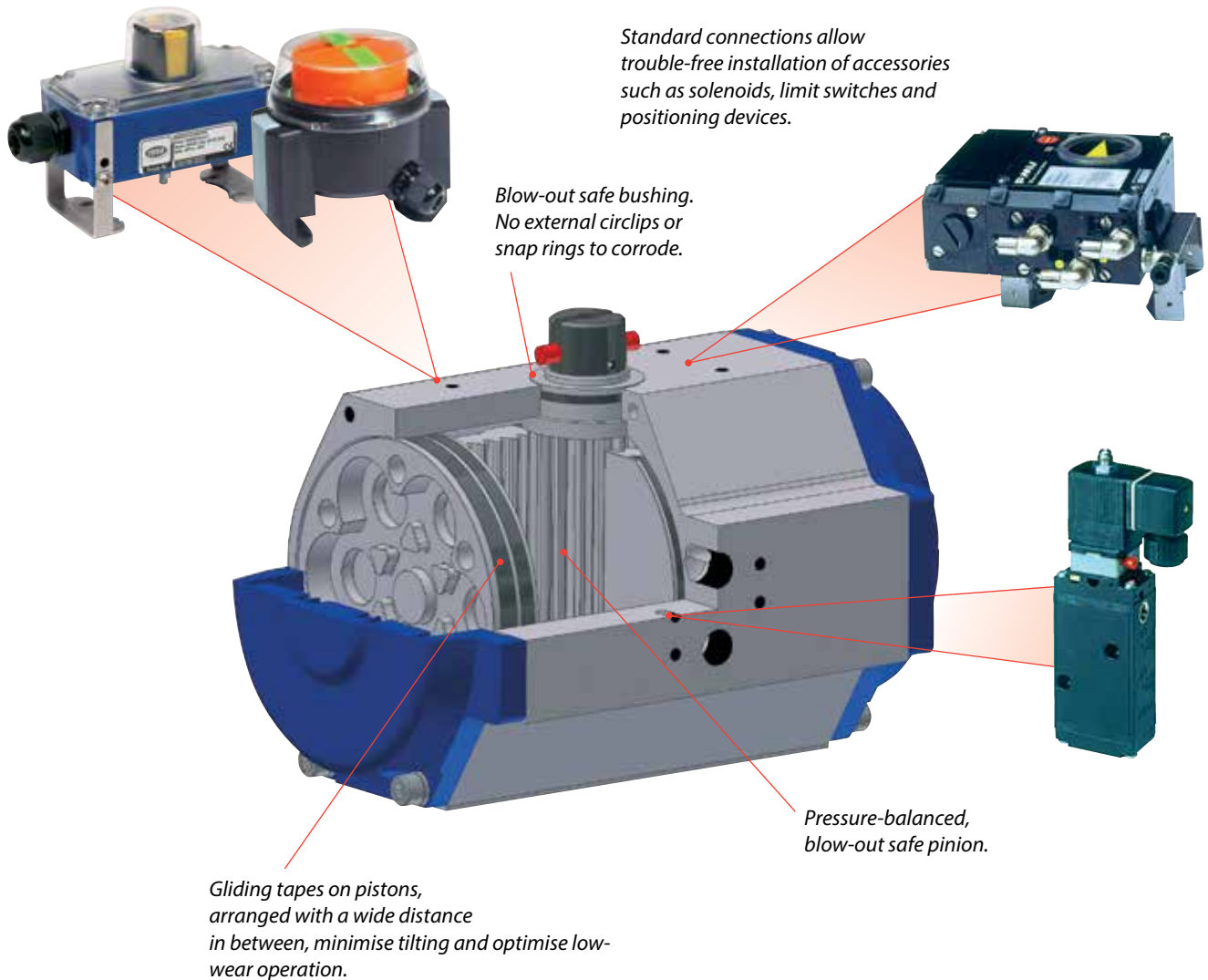

MAIN APPLICATIONS

- Power plants
- Sugar refining
- Petrochemical processing
- Waste incineration
- Food & Beverage production
- Steel manufacturing
- Pulp & Paper
- Chemical manufacturing

UNIQUE DESIGN FEATURES

- Patented, pressure balanced shaft prevent axial forces acting on the bearings. This results in high reliability, long lifetime and low wear.
- Shaft and the bearing bushings, mounted from inside, are of blow-out safe design, with no need for external circlips or snap rings, providing high operational safety.
- Robust anodised aluminium housings ensure an even expansion under thermal influences: no jamming of the piston and a high level of corrosion protection.
- Optimally positioned, self-lubricating sliding bands on the piston (made of graphite filled Teflon) ensure low friction operation with minimal risk of piston tilt, resulting in low wear.
- Left and right wounded springs avoid torsion force and provide proper actuation function.
- Interfaces comply with NAMUR and ISO-standards.
- Simple retrofitting of accessories, such as solenoid valves, limit switch and positioners.
- Compact design allows extensive direct mounting orientations.

Revo actuator options

**Standard Option.
Limit Stops for
012 to 180**



**Limit Stop Plates
for 205 to H15**



180° Actuator



**High and Low
Temperature Options**



**Multi-position
actuators**

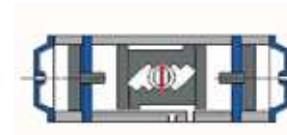

**Hydraulic
Dampening**

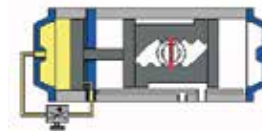

**Emergency
Gears**



**Coatings and
Special Finishes**



REVO ACTUATORS – SERIES R – TORQUES (NM)

Double Acting Actuators

torques are only valid for 0° to 90°

Model	Air Supply (bar)						
	2	3	4	5	6	7	8
RD 001	2,2	3,3	4,4	6,55	6,6	7,7	
RD 002	5	8	11	14	16	19	
RD 006	12	19	25	31	37	43	
RD 012	24	37	49	62	74	86	99
RD 025	48	72	96	120	144	168	192
RD 050	88	133	177	222	266	310	355
RD 090	168	253	337	422	506	590	675
RD 130	256	385	513	642	770	898	1027
RD 180	338	506	675	843	1012	1181	1349
RD 205	506	758	1011	1264	1517	1769	2022
RD 380	758	1138	1517	1897	2276	2655	3035
RD 630	1264	1896	2528	3160	3792	4424	5056
RD 960	1920	2879	3839	4798	5758	6718	7677
RD H15	2938	4407	5876	7345	8814	10283	11752

Single Acting Actuators

Model	Air Supply (bar)											
	2,5-2,9		3,0-3,9		4,0-4,9		5,0-5,9		6,0-6,9		7,0-8	
	Nm	No of Springs	Nm	No of Springs	Nm	No of Springs	Nm	No of Springs	Nm	No of Springs	Nm	No of Springs
RS/A 002	2	4	2,9	6	3,8	8	4,8	10	5,8	12		
RS/A 006	4,4	4	6,9	6	9,1	8	11,3	10	13,5	12		
RS/A 012	8	4	12	6	16	8	21	10	25	12	29	14
RS/A 025	16	4	44	6	32	8	40	10	48	12	56	14
RS/A 050	29	4	44	6	58	8	73	10	88	12	120	14
RS/A 090	53	4	80	6	107	8	134	10	160	12	187	14
RS/A 130	81	4	122	6	162	8	203	10	244	12	284	14
RS/A 180	107	4	160	6	213	8	267	10	320	12	373	14
RS/A 205	169	4	253	6	337	8	421	10	506	12	590	14
RS/A 380	253	4	379	6	506	8	632	10	758	12	885	14
RS/A 630	421	4	632	6	843	8	1053	10	1264	12	1475	14
RS/A 960	632	6	948	9	1264	12	1580	15	1896	18		
RS/A H15	979	4	1468	6	1958	8	2447	10	2937	12	3792	14

Other spring combinations possible.

FLANGE CONNECTIONS

Flange Connections – DIN/ISO 5211 and female square DIN 3337 Torques (Nm)

Connection	Torque (Nm ¹)	F03 V09	F04 V11	F05 V14	F07 V17	F10 V22	F12 V27	F14 V36	F16 V46	F16 V46	F25 V55	F25 V55	F30 V75
Pinion height		20	20	20	20	30	30	30	30	30	30	30	30
Drilling acc. DIN 3845		25x50	25x50	30x80	30x80 & 30x130	30x130	30x130	30x130	30x130	30x150	30x150	30x175	30x175
Model													
R 001	32												
R 002	32												
R 002	63												
R 006	32												
R 006	63												
R 006	125												
R 012	125												
R 025	125												
R 050	250												
R 090	250												
R 090	500												
R 130	500												
R 130	1000												
R 180	1000												
R 205	2000												
R 380	2000												
R 380*	4000												
R 630	4000												
R 960	4000												
R 960	8000												
R H15	8000												
R H15	16000												

¹maximum torques for the connection DIN/ISO 5211 *standard

Weight & Air Usage

Model	Weight		Air Consumption NL/ travel*
	DA kg	SR kg	
R 001	0,35	0,35	0,06
R 002	0,50	0,50	0,12
R 006	0,95	1,00	0,28
R 012	2,15	2,30	0,53
R 025	3,50	3,80	1,02
R 050	5,85	6,65	1,90
R 090	10,40	12,00	3,60
R 130	19,00	21,00	5,49
R 180	22,50	25,30	7,21
R 205	30,00	33,00	9,00
R 380	37,00	41,50	13,00
R 630	45,00	54,00	22,00
R 960	77,30	89,00	32,50
R H15	92,00	106,00	52,00

* norm liter at 1 bar per travel 0 - 90°

FIGURE NUMBERING SYSTEM

1	2	3	4	5	6	7	8	9	10	11	12	13	14	15
R	D	5	0	1	2	0	0	5	0	M	B	0	0	0



1 Series

R Revo Actuator

2 Function

D double acting
 S spring to close
 A spring to open
 E 180° actuator, DA
 F 180° actuator, SR
 G 180° actuator, SR
 H hydr.damper, DA
 K hydr.damper, SR
 L hydr.damper, SR
 M multi position 0-45°-90°
 N multi position 0-90°-180°

3 Version

5 90° actuator (012-H15)
 6 90° actuator (012-180)
 (incl. limit stops open/closed
 and 4° overtravel)
 7 90° actuator (001-006)

4, 5 + 6 Size

001
 002
 006
 012
 025
 :
 H15

— refer to standard data sheets

[INFO](#)

7, 8 + 9 Connection

003 F03, square 9mm
 004 F04, square 11mm
 005 F05, square 14mm
 007 F07, square 17mm
 010 F10, square 22mm
 012 F12, square 27mm
 014 F14, square 36mm
 016 F16, square 46mm
 025 F25, square 55mm
 030 F30, square 75mm

10 Number of springs

0 double acting
 1 single acting, 1 spring
 2 single acting, 2 springs
 3 single acting, 3 springs
 :
 9 single acting, 9 springs
 A single acting, 10 springs
 B single acting, 11 springs
 C single acting, 12 springs
 D single acting, 13 springs
 E single acting, 14 springs
 :
 K spring return, 18 springs
 (only for size 960)

11 + 12 Execution

00 standard -20° to 80°C
 MB High Temperature
 -20° to 140°C
 MC Low Temperature
 -40° to 80°C

13 + 14 Coating**

00 standard
 (anodized end cap RAL 5002)

*except 001 – 006, RAL 5009

15 Misc.

0 Standard

INFO – Rule of thumb
 size = torques at 1 bar,
 eg. 012 at 6 bar:
 12Nm x 6 bar = 72Nm

DIMENSIONS

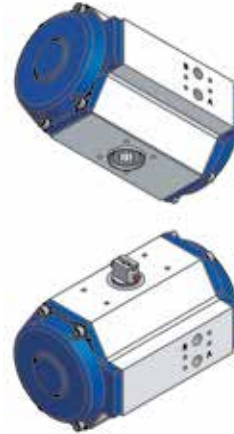
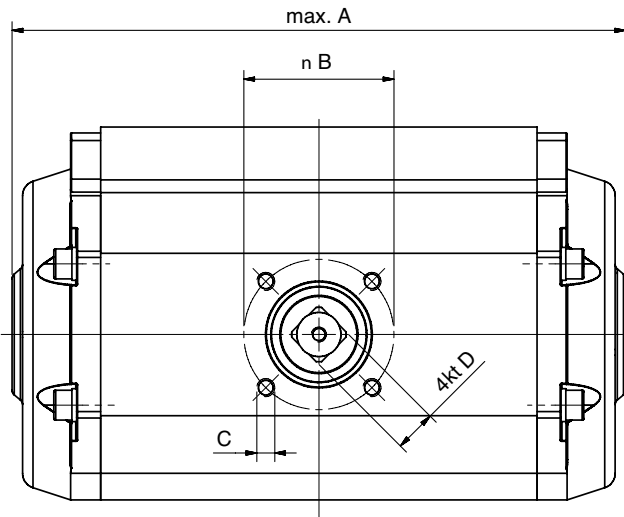

Diameter for size 012-H15: n E

DOUBLE-"D" for size 001-006: 14

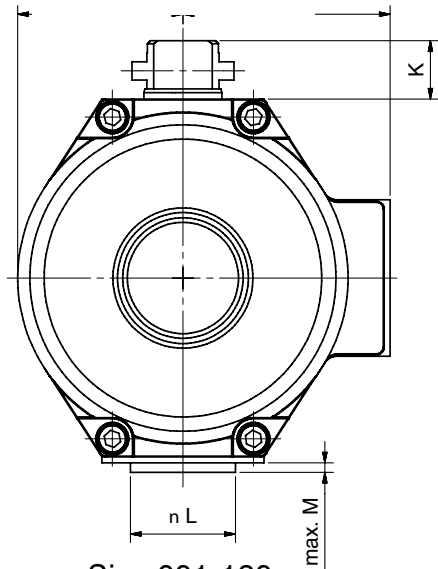
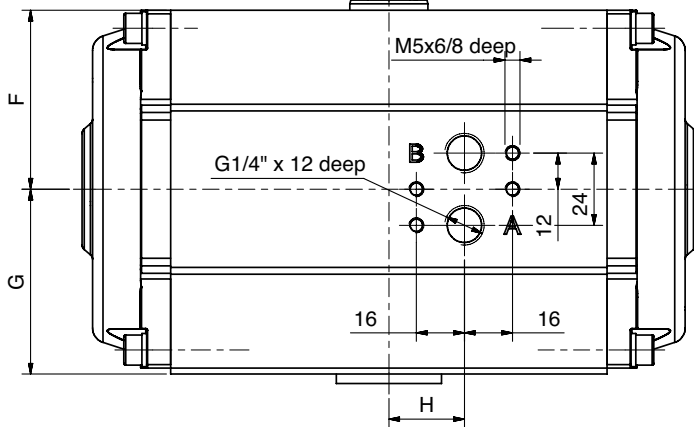
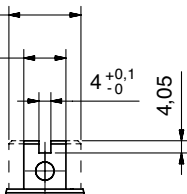

Size 001-180

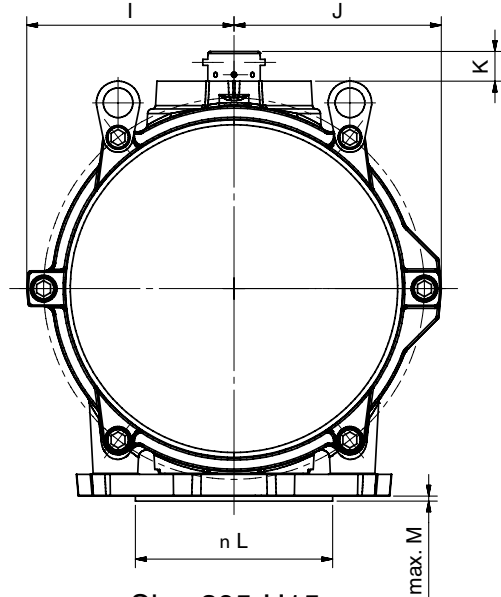
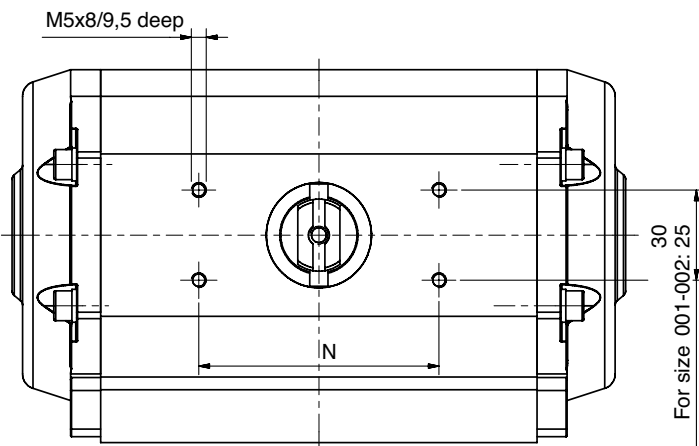

Size 205-H15

Model	Connection	Function	A	B	C	D	E	F	G	H	I	J	K	L	M	N
R 001	F03	DA/SR	120	Ø36	(4x) M5x8/10	9H11x10	-	22±1	24±1	-	20,5±0,5	30,5±0,5	20±1	-	-	50
R 002	F03	DA/SR	170	Ø36	(4x) M5x8/9	9H11x12	-	27,5±2	29±1	-	25,5±0,5	33±0,5	20±1	-	-	50
R 002	F04	DA/SR	170	Ø42	(4x) M8x12,5/14	11H11x12	-	27,5±2	29±1	-	25,5±0,5	33±0,5	20±1	-	-	50
R 006	F03	DA/SR	205	Ø36	(4x) M5x8/9	9H11x17	-	37,5±2	39±1	-	34,7±0,5	41,5±0,5	20±1	-	-	80
R 006	F04	DA/SR	205	Ø42	(4x) M5x7,5/11	11H11x17	-	37,5±2	39±1	-	34,7±0,5	41,5±0,5	20±1	-	-	80
R 006	F05	DA/SR	205	Ø50	(4x) M6x10/11	14H11x17	-	37,5±2	39±1	-	34,7±0,5	41,5±0,5	20±1	-	-	80
R 012	F05	DA/SR	215	Ø50	(4x) M6x8,8/9,8	14H11x17+1	Ø24	44,5±1,5	46,5±1	25,05±1	41±1	55,5±1	20±1	Ø35	3	80
R 025	F05	DA/SR	220	Ø50	(4x) M6x8,8/9,8	14H11x17+1	Ø24	59,5±1,5	61,±1	25,15±1	55±0,5	69±1	20±1	Ø35	3	80
R 050	F07	DA/SR	280	Ø70	(4x) M8x12,5/14	17H11x21+1	Ø24	71,5±1,5	74,5±1,5	32,25±1	67±1	81±1	20±1	Ø55	3	80(130)
R 090	F07	DA/SR	365	Ø70	(4x) M8x13/14,5	17H11x21+1	Ø24	81,5±2,5	84,5±1,5	46,85±1	78±1	96±1,5	20±1	Ø55	3	80(130)
R 090	F10	DA/SR	365	Ø102	(4x) M10x16/18,5	22H11x25+1	Ø24	81,5±2,5	84,5±1,5	46,85±1	78±1	96±1,5	30±1	Ø70	4	130
R 130	F10	DA/SR	430	Ø102	(4x) M10x16/18,5	22H11x25+1	Ø24	94±3	98±2	54,5±1	90±1,5	102±1,5	30±1	Ø70	4	130
R 130	F12	DA/SR	430	Ø125	(4x) M12x18/22	27H11x30+1	Ø24	94±3	98±2	54,5±1	90±1,5	102±1,5	30±1	Ø85	4	130
R 180	F12	DA/SR	440	Ø125	(4x) M12x18/22	27H11x30+1	Ø24	106,5±3	111,5±1,5	54,5±1	102±1,5	116±1,5	30±1	Ø85	4	130
R 205	F14	SR	500	Ø140	(4x) M16x26/27,5	36H11x40+1	Ø53	137±3	137±3	67,5±1	136±2,5	140±3	30±1	Ø100	4	130
R 205	F14	DA	390	Ø140	(4x) M16x26/27,5	36H11x40+1	Ø53	137±3	137±3	67,1±1	136±2,5	140±3	30±1	Ø100	4	130
R 380	F14	SR	610	Ø140	(4x) M16x26/27,5	36H11x40+1	Ø53	137±3	147±3	96,5±1	136±2,5	140±3	30±1	Ø100	4	130
R 380	F14	DA	500	Ø140	(4x) M16x26/27,5	36H11x40+1	Ø53	137±3	147±3	96,5±1	136±2,5	140±3	30±1	Ø100	4	130
R 380	F16	SR	610	Ø165	(4x) M20x30/32	46H11x50+1	Ø53	137±3	147±3	96,5±1	136±2,5	140±3	30±1	Ø130	5	130
R 380	F16	DA	500	Ø165	(4x) M20x30/32	46H11x50+1	Ø53	137±3	147±3	96,5±1	136±2,5	140±3	30±1	Ø130	5	130
R 630	F16	SR	755	Ø165	(4x) M20x22/27	46H11x50+1	Ø53	172±3,5	172±3,5	99±1	175±3,5	177±3,5	30±1	Ø130	5	130
R 630	F16	DA	520	Ø165	(4x) M20x22/27	46H11x50+1	Ø53	172±3,5	172±3,5	99±1	175±3,5	177±3,5	30±1	Ø130	5	130
R 960	F16	SR	760	Ø165	(4x) M20x25	46H11x50+1	Ø53	210±4	210±4	96,41±1	210±4	210±4	30±1	Ø130	5	150
R 960	F16	DA	540	Ø165	(4x) M20x25	46H11x50+1	Ø53	210±4	210±4	96,41±1	210±4	210±4	30±1	Ø130	5	150
R 960	F25	SR	760	Ø254	(8x) M16x25	55H11x59+1	Ø53	210±4	210±4	96,41±1	210±4	210±4	30±1	Ø200	5	150
R 960	F25	DA	540	Ø254	(8x) M16x25	55H11x59+1	Ø53	210±4	210±4	96,41±1	210±4	210±4	30±1	Ø200	5	150
R H15	F25	SR	920	Ø254	(8x) M16x25	55H11x59+1	Ø53	225±4,5	225±4,5	136±1	223,5±4,5	223,5±4,5	30±1	Ø230	5	175
R H15	F25	DA	700	Ø254	(8x) M16x25	55H11x59+1	Ø53	225±4,5	225±4,5	136±1	223,5±4,5	223,5±4,5	30±1	Ø230	5	175
R H15	F30	SR	920	Ø298	(8x) M20x25	75H11x79+1	Ø53	225±4,5	225±4,5	136±1	223,5±4,5	223,5±4,5	30±1	Ø230	5	175
R H15	F30	DA	700	Ø298	(8x) M20x25	75H11x79+1	Ø53	225±4,5	225±4,5	136±1	223,5±4,5	223,5±4,5	30±1	Ø230	5	175



Crane ChemPharma & Energy

Crane Process Flow Technologies GmbH
Revo Antriebs- und Automatisierungstechnik
Heerdter Lohweg 63-71, D-40549 Düsseldorf
Telefon +49 211 5956-0 ,Telefax +49 211 5956-111

www.cranecpe.com

CRANE

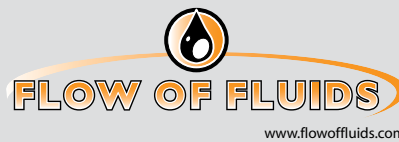

brands you trust.



CPE-REVO-OVERVIEW-EN-A4-2014_09_07

Crane Co., and its subsidiaries cannot accept responsibility for possible errors in catalogues, brochures, other printed materials, and website information. Crane Co. reserves the right to alter its products without notice, including products already on order provided that such alteration can be made without changes being necessary in specifications already agreed. All trademarks in this material are property of the Crane Co. or its subsidiaries. The Crane and Crane brands logotype, in alphabetical order, (ALOYCO®, CENTER LINE®, COMPAC-NOZ®, CRANE®, DEPA®, DUO-CHEK®, ELRO®, FLOWSEAL®, JENKINS®, KROMBACH®, NOZ-CHEK®, PACIFIC VALVES®, RESISTOFLEX®, REVO®, SAUNDERS®, STOCKHAM®, TRIANGLE®, UNI-CHEK®, WTA®, and XOMOX®) are registered trademarks of Crane Co. All rights reserved.