



ENAPART



93 S Railroad Avenue Unit C
Bergenfield NJ 07621 USA
www.enapart.com
sales@enapart.com



Via del Canneto 35,
Borgosatollo, Brescia - Italia
www.enapart.it
vendite@enapart.it



Barbaros Mah. Ihlamur Bul. Aĝaoĝlu
My Newwork No:3/15 Ataşehir / İstanbul
www.enapart.net
satis@enapart.net



PRIVADA 10 B SUR #3908 COL.
ANZUREZ, C.P. 72530, PUEBLA, PUE
www.enapart.com.mx
sales@enapart.com.mx



Friedrich-Ebert-Anlage 36, 60325
Frankfurt am Main, Germany
www.enapart.de
anfrage@enapart.de



4 boulevard Carnot, 95400
villiers-le-bel, Paris, France
www.enapart.fr
sales@enapart.fr



65049, ОДЕСА, ВУЛИЦЯ ІВАНА
ФРАНКА, БУДИНОК 55, ПОВЕРХ 3
www.enapart.com.ua
sales@enapart.com.ua



MUNICIPIUL BUCUREȘTI, SECTOR 3,
B-DUL BASARABIA, NR.250, CORP P+5
www.enapart.ro
sales@enapart.ro



〒584-0023 大阪府富田林市若松町
東2丁目2番16号
www.enapart.co.jp
sales@enapart.co.jp



PLAZA NUESTRA SEÑORA DE LAS
NIEVES 12 ,LOCAL ,50012,ZARAGOZA
www.enapart.es
ventas@enapart.es



Складова база „Онгъл“, Склад А2, п.к.
4006, гр. Пловдив, България
www.enapart.bg
sales@enapart.bg



3 Austin Mews, High Street, Hemel
Hempstead, HP1 3AF , United Kingdom
www.enapart.co.uk
sales@enapart.co.uk



MADE IN ITALY

Hygienic LINE

MOTORI A PROFILO PULITO
HYGIENIC WASHDOWN MOTORS
IE4 PREMIUM EFFICIENCY



Applicazioni | Applications



 Nuova linea di motori a profilo pulito in grado di garantire la protezione e la sicurezza che avete sempre cercato.

 New motor line with cleaning profile, capable of guaranteeing the protection and the cleaning that you have always looked for.

Hygienic Line



GHA



p.7

NICKEL



p.13

INOX



p.17

Questo documento annulla e sostituisce ogni precedente edizione o revisione.

Carpanelli S.p.A si riserva il diritto di apportare modifiche al documento senza preavviso.

This document cancels and replaces any previous edition and revision.

Carpanelli S.p.A reserves the right to implement modifications without notice.

PULIZIA
SEMPLICESIMPLE
CLEANINGPULIZIA AD ALTA
PRESSIONEHIGH PRESSURE
CLEANINGPULIZIA AD ALTA
PRESSIONE CON
SODA CAUSTICAHIGH PRESSURE
CLEANING WITH
CAUSTIC SODAAMBIENTE
SECCODRY
ENVIRONMENTAMBIENTE
POLVEROSODUSTY
ENVIRONMENTAMBIENTE
UMIDOMOIST
ENVIRONMENTAMBIENTE
SANITARIOSANITARY
ENVIRONMENTAMBIENTE
ASETTICOASEPTIC
ENVIRONMENTAMBIENTE
MARINOMARINE
ENVIRONMENTAMBIENTE
CORROSIVO
(PH < 10)CORROSIVE
ENVIRONMENT
(PH < 10)AMBIENTE
ACIDOACIDIC
ENVIRONMENT

Opzioni aggiuntive | Additional features

FRENI

BRAKES

Tutti i motori sono disponibili anche nella versione **autofrenante**, con i seguenti freni:

- Freno in **C.C.** (corrente continua) con alimentazione diretta
- Freno in **C.C.** con alimentazione separata in C.A., con raddrizzatore

All motors are available also as **brake motors**, with following brakes:

- **DC** brake (direct current) with direct connection
- **DC** brake with separate connection, with rectifier

TAGLIA MOTORE SIZE OF THE MOTOR	FRENO C.C. DC BRAKE (Nm)
M63	1.8
M71	4
M80	8
M90	16

TRASDUTTORI DI POSIZIONE

POSITION TRANSDUCERS

Tutti i motori sono disponibili anche con i seguenti **trasduttori di posizione**:

- **Encoder** incrementali fino a 65000 imp/giro, assoluti o con BUS di campo
- **Resolver**

All motors are available also with the following **position transducer**:

- Incremental **Encoder** up to 65000 pulse/rev, absolute encoder or with field BUS
- **Resolver**

MATERIALE ALBERO

SHAFTS MATERIAL

Gli **alberi** di tutti i motori della linea igienica sono in AISI 420; su richiesta è possibile realizzare gli alberi in AISI 316.

The **shafts** of all the motors of the hygienic line are in AISI420; upon request it is possible to use AISI 316.

MORSETTIERA

TERMINAL BLOCK

I motori nella versione standard vengono forniti con cavo 3+1x0,5m. Su richiesta è possibile utilizzare un cavo differente o, come opzione aggiuntiva, avere la morsettiera, senza cavo.

These motors in the standard version are supplied with 3+1 x 0,5m cable. Upon request it is possible to use a different cable or, as an additional feature, to have the terminal block, without cable.

SONO POSSIBILI COSTRUZIONI SPECIALI SU RICHIESTA DEL CLIENTE.

SPECIAL VERSIONS CAN BE MADE FOLLOWING CUSTOMER'S REQUEST.

www.carpanelli.net

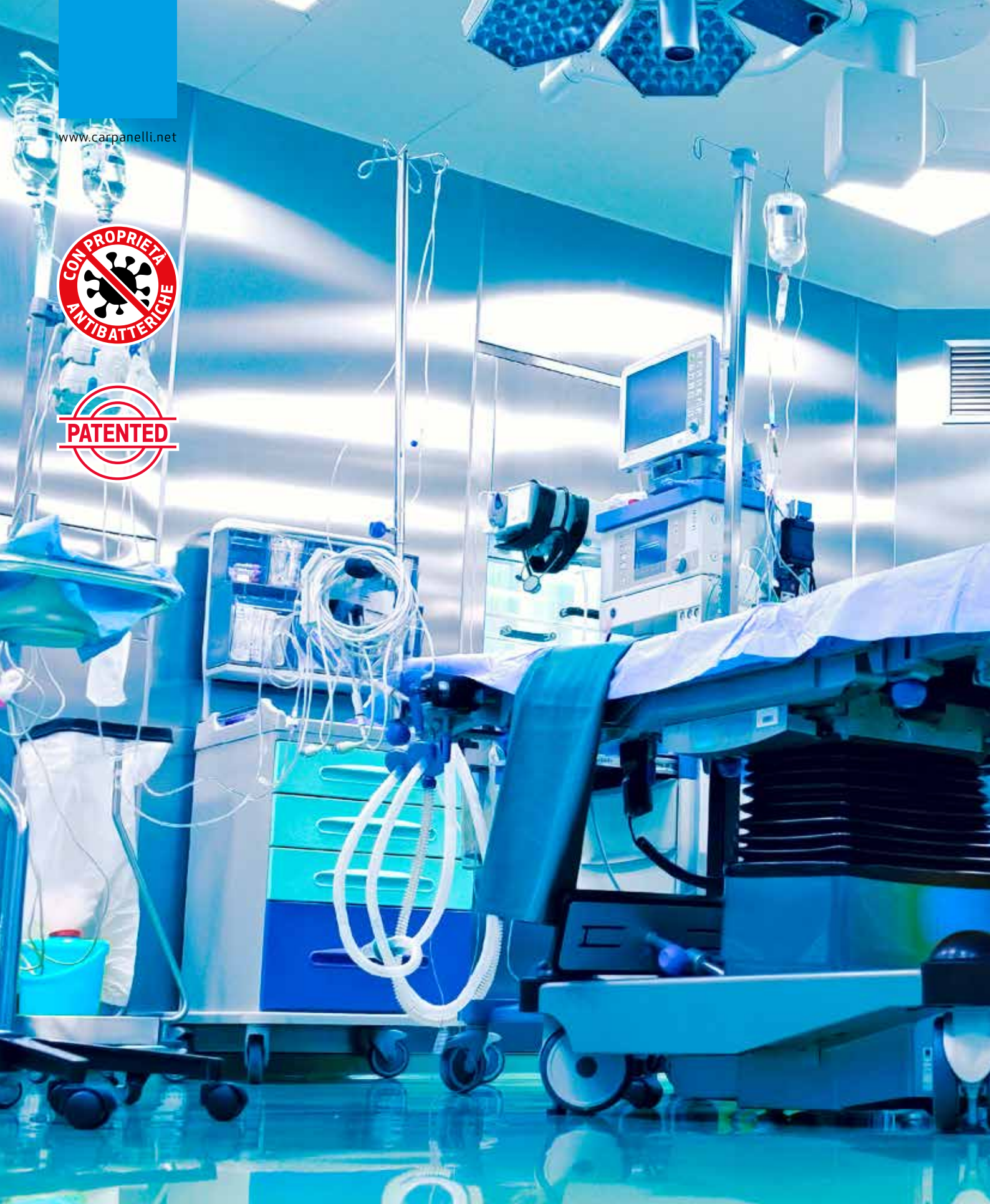

CARATTERISTICHE

CHARACTERISTICS

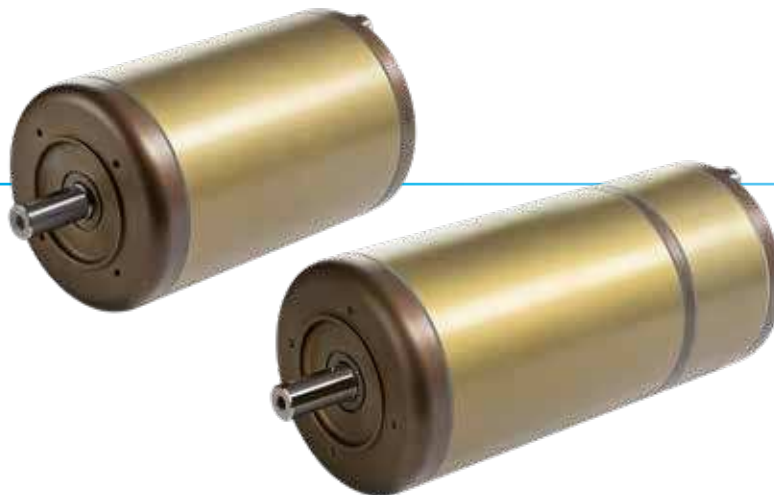

Nuova linea di motori con **trattamento all'argento**, brevettato Carpanelli Motori Elettrici S.p.A.

Questo nuovo **trattamento all'argento** ideato per motori in lega di alluminio, conferisce ai motori **proprietà antibatteriche** ed offre quindi una **valida alternativa ai motori in inox** o ad altri trattamenti costosi per quei settori, come l'**alimentare** o il **farmaceutico**, in cui è necessario mantenere un ambiente pulito e asettico. Questo trattamento conferisce ai motori proprietà come:

- **Resistenza ai principali agenti corrosivi**, portando quindi i motori allo stesso livello di quelli in lega di acciaio inox;
- **Migliore conducibilità elettrica e termica**, facendo sì che il motore dissipi il calore il 35% in più rispetto all'alluminio non trattato e 10 volte di più rispetto all'acciaio inox;
- **Proprietà antimuffa e battericide**, rendendo così questi motori più indicati che i motori in acciaio inox per ambienti asettici;
- **Elevata resistenza all'usura** abrasiva;
- **Elevata durezza**.

I principali punti di forza di questa nuova linea rispetto ai motori in acciaio inox, sono i seguenti:

- **Proprietà battericide** nei confronti dei principali batteri dannosi per l'organismo umano;
- **Peso totale inferiore**, in quanto l'alluminio pesa 1/3 dell'acciaio inox;
- **Amagnetico** e capace quindi di **soportare voltaggi elevati**;
- **Elevata conducibilità termica** (204 W/m °C) rispetto all'acciaio inox (15 W/m °C), quasi 15 volte superiore;
- **Maggiore efficienza** del motore, in quanto la maggiore capacità dissipante mantiene il motore più freddo e quindi con una resistenza intrinseca minore, mantenendo così l'efficienza del motore;

New motor line with **silver treatment**, patented by Carpanelli Motori Elettrici S.p.A.

This new **silver treatment** created for aluminium alloy motors, gives the motors **antibacterial properties** and as such offers a **valid alternative to stainless steel motors** or indeed other expensive treatments. These motors are perfect for those industries, such as **food** and **pharmaceutical**, where a clean and aseptic environment is needed. This treatment gives the motors interesting characteristics, such as:

- **Resistance to corrosive agents**, bringing the motors to the same level as stainless steel motors;
- **Better electrical and thermal conductivity**, allowing the motor to dissipate 35% more heat than non-treated aluminium, and 10 times more than stainless steel;
- **Anti-mould and germicidal properties**, making these motors suitable for aseptic environments than stainless steel motors;
- **High resistance to abrasive wear**;
- **High hardness**.

The main advantages of these new motors, compared to stainless steel motors, are:

- **Germicidal properties** against the principal bacteria dangerous to the human organism;
- **Lower weight**, because aluminium weighs 1/3 of stainless steel;
- **Non-magnetic** and therefore **capable of resisting high voltages**;
- **High thermal conductivity** (204 W/m °C) compared to stainless steel (15 W/m °C), almost 15 times more;
- **Higher motor efficiency**, the greater heat dissipation of aluminium keeps the motor cooler and, consequently, the lower intrinsic resistance, keeps the motor's efficiency constant;

CARATTERISTICHE

CHARACTERISTICS

I vantaggi dell'utilizzo di questi motori invece dei motori in acciaio inox, sono numerosi:

- **Sicurezza e asetticità:** la proprietà antibatterica dell'argento consente di impiegare questi motori anche a contatto con generi alimentari, prevenendo la proliferazione batterica e quasi "disinfettando" gli alimenti stessi, vantaggio interessante per quelle aziende che devono osservare le norme internazionali per la garanzia dell'igienicità del prodotto. Inoltre, i materiali di fabbricazione sono atossici e non assorbenti, quindi, nelle condizioni di uso previste, non rilasciano sostanze tossiche e non trattengono le sostanze con cui entrano in contatto.
- **Nickel-free:** mentre l'acciaio inox contiene nickel, i motori antibatterici ne sono privi. Come è noto, il nickel è risultato essere dannoso per l'organismo umano; questo innovativo trattamento all'argento consente di evitare questo problema.
- **Prestazioni elettriche:** l'elevata conducibilità termica dell'alluminio trattato all'argento permette al motore di dissipare il calore con un rapporto 10 volte superiore all'acciaio inox; la carcassa rimane quindi più fredda. Il fatto di lavorare a temperature inferiori garantisce una maggiore durata dei componenti, una capacità di condensa interna inferiore e, inoltre, il motore non costituisce un pericolo per gli operatori che potrebbero venirne in contatto. Anche il grado di efficienza del motore elettrico è favorito dalla temperatura inferiore.

PULIZIA DELLE SUPERFICI TRATTATE:

I particolari sottoposti a trattamento all'argento sono sensibili a pH eccessivamente acidi o eccessivamente basici. Si consiglia pertanto di pulire le zone interessate con lavaggi neutri o mediamente aggressivi, il cui pH sia compreso tra 4 e 9. In questo modo la resistenza alla corrosione e il potere antibatterico saranno garantiti.

The main advantages of using these motors instead of stainless steel motors are:

- **Safety and sterility:** silver's antibacterial properties allow the motors to be used in close contact with food, preventing microbial contamination and somehow "disinfecting" the food; interesting advantage for those companies that have to observe international norms for the hygiene of their products. In addition to that, the materials used in the manufacture of these motors are non-toxic and non-absorbent, so, in any given working environment, they do not release or retain any toxic contamination that they may have been in contact with.
- **Nickel-free:** while stainless steel contains Nickel, antibacterial motors don't. As it is known, Nickel is dangerous for the human organism; this innovative silver treatment avoids this problem.
- **Electrical performances:** the high thermal conductivity of this aluminium treated with silver, permits the motor to dissipate 10 times more heat than stainless steel; the motors will therefore run much cooler. Working at lower temperatures guarantees a longer life of the components, a reduced chance of wear and corrosion of internal components and, in addition to that, they are not dangerous for operatives that may come into contact with the motor's surface. Also the electrical efficiency level of the motor takes advantage from the lower temperature.

CLEANING OF THE TREATED SURFACES:

Surfaces treated with silver are sensitive to too acidic or too basic pH. Therefore, it is suggested to clean the surfaces with neutral or barely aggressive washings, with pH between 4 and 9. In this way, resistance to corrosion and antibacterial properties are guaranteed.

DATI TECNICI

TECHNICAL DATA

IE4 Efficiency		Potenza nominale Nominal Power		Velocità Speed	Rendimento Efficiency	Corrente nominale Nominal Current	Fattore di potenza Power Factor	Coppia nominale Nominal Torque	Rapporti di spunto Starting Ratio	
Tipo Type	Pn		n	μ	An	Cos φ	Cn	Cs/Cn	As/An	
	[kW]	[Hp]	[rpm]	[%IE4]	[A]	-	[Nm]	-	-	
2 POLI / POLES	MHA63a2	0.13	0.18	2890	67.4	0.37	0.73	0.43	5.0	7.56
	MHA63b2	0.18	0.25	2850	70.8	0.43	0.81	0.61	4.2	6.36
	MHA63c2	0.25	0.37	2880	74.3	0.58	0.81	0.84	4.5	7.9
	MHA71a2	0.37	0.5	2880	78.1	0.78	0.85	1.23	4.2	9.0
	MHA71b2	0.5	0.75	2880	80.8	1.0	0.86	1.66	5.5	9.0
	MHA80a2	0.75	1.0	2940	83.5	1.6	0.8	2.44	6.5	14.7
	MHA90a2	1.1	1.5	2940	85.2	2.32	0.81	3.6	5.22	8.27
	MHA90b2	1.5	2.0	2900	86.5	3.25	0.78	5.0	4.79	9.83
4 POLI / POLES	MHA63a4	0.13	0.18	1400	70.9	0.38	0.73	0.88	3.6	6.5
	MHA63b4	0.18	0.25	1420	74.5	0.48	0.73	1.25	3.78	6.4
	MHA71a4	0.25	0.37	1440	77.9	0.56	0.81	1.7	3.7	7.2
	MHA71b4	0.37	0.5	1440	81.1	0.83	0.79	2.44	4.63	8.34
	MHA80a4	0.5	0.75	1450	83.2	1.24	0.71	3.3	5.25	8.43
	MHA80b4	0.75	1.0	1450	85.7	1.77	0.72	4.95	5.8	8.52
	MHA90a4	1.1	1.5	1440	87.2	2.28	0.79	7.3	4.2	8.9
	MHA90b4	1.5	2.0	1460	88.2	3.16	0.77	9.85	4.9	10.0
6 POLI / POLES	MHA63a6	0.09 ⁽¹⁾	0.12	900	61.5	0.3	0.7	0.95	2.2	3.2
	MHA63b6	0.13	0.18	880	65.9	0.42	0.69	1.41	2.5	3.3
	MHA71a6	0.18	0.25	890	70.1	0.53	0.7	1.95	2.6	3.0
	MHA71b6	0.25	0.37	890	74.1	0.72	0.69	2.65	3.2	3.4
	MHA80a6	0.37	0.5	890	78.0	0.98	0.7	3.97	1.7	3.4
	MHA80b6	0.5	0.75	900	80.3	1.25	0.72	5.3	2.4	3.7
	MHA90a6	0.75	1.0	950	82.7	1.65	0.77	7.6	2.6	5.7
	MHA90b6	1.1	1.5	950	84.5	2.4	0.78	11.1	2.9	6.1

(1): Classificazione IE non ancora disponibile

(1): IE classification not available yet.

ATTENZIONE: I dati tecnici riportati nella tabella si riferiscono ad una tensione di alimentazione di 230/400V, 50Hz.
Votaggi diversi solo su richiesta.

WARNING: Technical data reported in the table refer to voltage 230/400V, 50Hz.
Different voltages only on request.



DIMENSIONI

DIMENSIONS

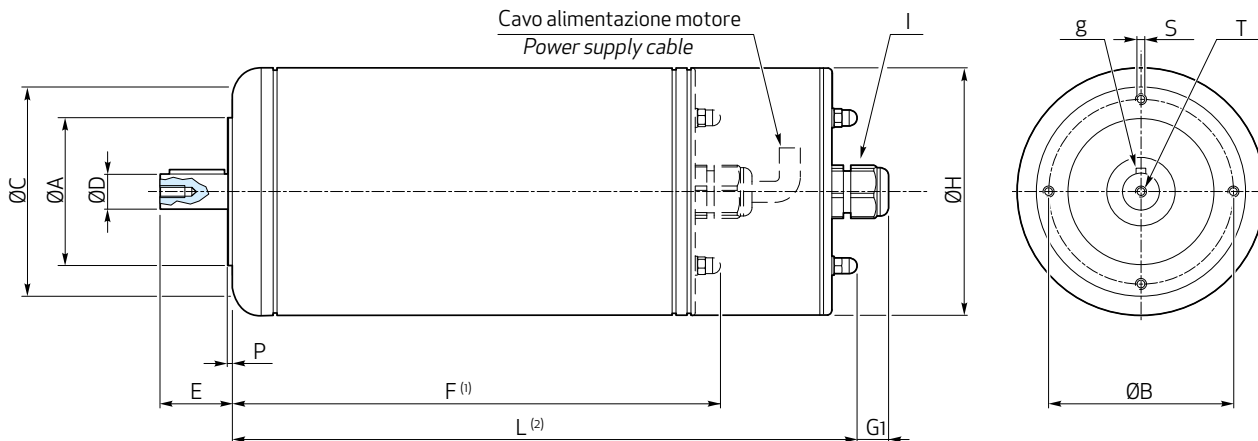

MHA	B14													B14 maggiorata / oversize									
	A j6	B	C	D j6	E	g	F (1)	L (2)	G1	H	I	P	S	T	A j6	B	C	D j6	E	g	P	S	T
MHA63	60	75	90	11	23	4	235	300	16	118	M20X1,5	2	M5	M4	70	85	105	14	30	5	2,5	M6	M5
MHA71	70	85	105	14	30	5	246	323	16	134	M20X1,5	2,5	M6	M5	80	100	120	19	40	6	3	M6	M6
MHA80	80	100	120	19	40	6	271	347	16	150	M20X1,5	3	M6	M6	95	115	140	24	50	8	3	M8	M8
MHA90	95	115	140	24	50	8	339	433	16	190	M20X1,5	3	M8	M8	110	130	160	28	60	8	3,5	M8	M10

MHA	B5 (3)													
	A j6	B	C	D j6	E	g	F (1)	L (2)	G1	H	I	P	S	T
MHA90	130	165	200	24	50	8	339	433	16	190	M20x1,5	3,5	M10	M8

(1): Motore standard.

(2): Motore con opzioni aggiuntive.

(3): Su richiesta è possibile avere la flangia B5 anche per le altre grandezze.

(1): Standard motor.

(2): Motor with additional features.

(3): Upon request it is possible to have the B5 flange also for the other sizes.



SONO STATI ESEGUITI TEST SUI SEGUENTI BATTERI :

TESTS HAVE BEEN CARRIED OUT ON FOLLOWING BACTERIA:

- Legionella Pneumophila
- Candida Albicans
- Staphylococcus Aureus
- Salmonella Typhimurium
- Escherichia Coli
- Pseudomonas Aeruginosa

Per maggiori informazioni consultare la pagina dedicata al motore GHA nella sezione Applicazioni sul nostro sito www.carpanelli.net.

For further information please visit the GHA page on our website www.carpanelli.net, section Applications.



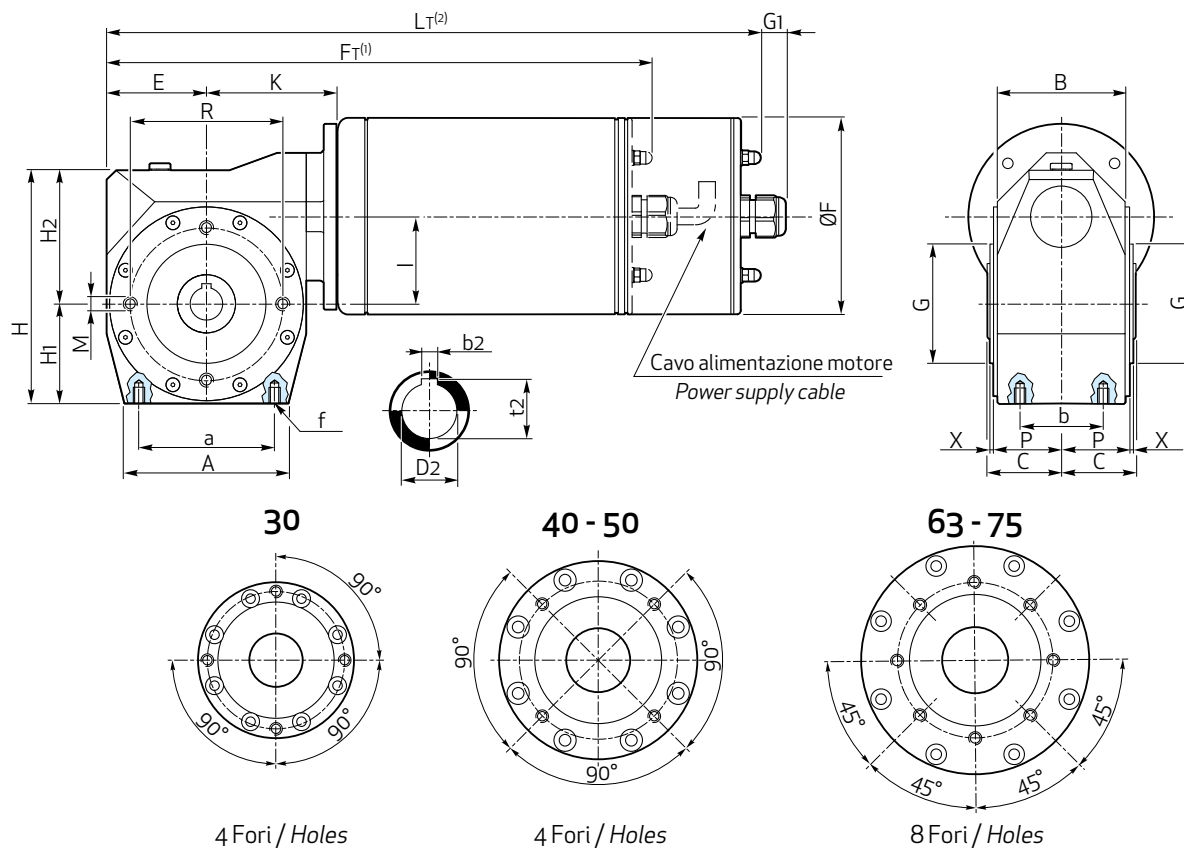

TAGLIA SIZE	A	a	B	b	b ₂	C	D _{2H8}	E	f	G _{H8}	H	H ₁	H ₂	I	K	M	P	R	t ₂	X
30	66	54	56	44	5	31.5	14	40	M6 x 9	55	93	40	53	31.5	57	4xM6x8	29	65	16.3	1.5
40	85	70	71	60	6	39	18	50	M6 x 11	60	116	50	66	40	75	4xM6x10	36.5	75	20.8	1.5
50	95	80	84	70	8	46	25	60	M8 x 12	70	142	60	82	50	82	4xM8x10	43.5	85	28.3	1.5
63	118	100	101	85	8	56	25	72	M8 x 16	80	173	72	101	63	96.8	8xM8x14	53	95	28.3	2
75	142	120	110	90	8	60	28	83	M10 x 16	95	201	86	115	75	112	8xM8x14	57	115	31.3	2

B14	TAGLIA RIDUTTORE / SIZE WORMGEARBOXES											
	30		40			50			63		75	
M flanges	M63	M63	M71		M71		M80		M80	M90	M90	
MHA	MHA63		MHA71		MHA63	MHA71		MHA80	MHA71	MHA80	MHA90	MHA90
F	Ø118		Ø134		Ø118	Ø134		Ø150	Ø134	Ø150	Ø190	
F _T (1)	332	360		371	383	394		419	415	440	508	537
G1	16 (con pressacavo standard / with standard cable gland)											
L _T (2)	397	437		448		471		495	492	516	602	631

(1): Motore standard.

(2): Motore con opzioni aggiuntive.

Per informazioni più dettagliate, chiedere al nostro ufficio commerciale

(1): Standard motor.

(2): Motor with additional features.

For more detailed information, please contact our sales department





NICKEL

CHARACTERISTICS

CARATTERISTICHE



Nuova linea di **motori in alluminio** con **trattamento al nichel**.

Il nichel è un metallo argenteo appartenente al gruppo del ferro, che lavora come un **impermeabile**, facendo sì che gli agenti corrosivi non riescano a raggiungere il materiale metallico di base, **proteggendolo così da usura, invecchiamento e corrosione**.

Lo strato di nichel depositato sul motore lo rende **esteticamente molto simile ai motori in acciaio inox**.

Questo trattamento, oltre ad **aumentare la durezza superficiale** dei motori, li rende adatti ad un **ambiente relativamente umido**, nel quale si effettuano **lavaggi frequenti** senza agenti chimici.

New motors line in **aluminum** with **nickel treatment**.

Nickel is a silvery-white metal that belongs to the iron group of metals. The Nickel forms an **impervious** coating on the motor frame, so that corrosive agents can't reach the Aluminum surface of the motor, and it **protects the motor from wear, ageing and corrosion**.

The nickel layer deposited on the motor makes it **aesthetically similar to stainless steel motors**.

This treatment, besides **increasing the exterior hardness** of the motors, makes them suitable for **moderately moist environments**, where **frequent cleanings** without chemical agents are carried out.

DIMENSIONI

DIMENSIONS

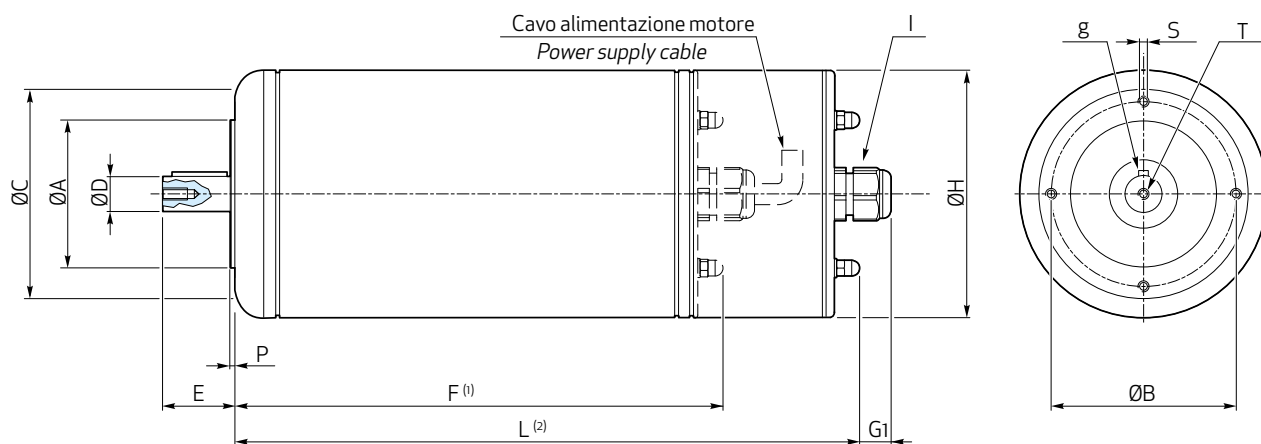

MHN	B14													B14 maggiorata / oversize									
	A j6	B	C	D j6	E	g	F (1)	L (2)	G1	H	I	P	S	T	A j6	B	C	D j6	E	g	P	S	T
MHN63	60	75	90	11	23	4	235	300	16	118	M20X1,5	2	M5	M4	70	85	105	14	30	5	2,5	M6	M5
MHN71	70	85	105	14	30	5	246	323	16	134	M20X1,5	2,5	M6	M5	80	100	120	19	40	6	3	M6	M6
MHN80	80	100	120	19	40	6	271	347	16	150	M20X1,5	3	M6	M6	95	115	140	24	50	8	3	M8	M8
MHN90	95	115	140	24	50	8	339	433	16	190	M20X1,5	3	M8	M8	110	130	160	28	60	8	3,5	M8	M10

MHN	B5													
	A j6	B	C	D j6	E	g	F (1)	L (2)	G1	H	I	P	S	T
MHN90	130	165	200	24	50	8	339	433	16	190	M20x1,5	3,5	M10	M8

(1): Motore standard.

(2): Motore con opzioni aggiuntive.

(1): Standard motor.

(2): Motor with additional features.

DATI TECNICI

TECHNICAL DATA

IE4 Efficiency		Potenza nominale Nominal Power		Velocità Speed	Rendimento Efficiency	Corrente nominale Nominal Current	Fattore di potenza Power Factor	Coppia nominale Nominal Torque	Rapporti di spunto Starting Ratio	
Tipo Type	Pn		n	μ	An	Cos φ	Cn	Cs/Cn	As/An	
	[kW]	[Hp]	[rpm]	[%IE4]	[A]	-	[Nm]	-	-	
2 POLI / POLES	MHN63a2	0.13	0.18	2890	67.4	0.37	0.73	0.43	5.0	7.56
	MHN63b2	0.18	0.25	2850	70.8	0.43	0.81	0.61	4.2	6.36
	MHN63c2	0.25	0.37	2880	74.3	0.58	0.81	0.84	4.5	7.9
	MHN71a2	0.37	0.5	2880	78.1	0.78	0.85	1.23	4.2	9.0
	MHN71b2	0.5	0.75	2880	80.8	1.0	0.86	1.66	5.5	9.0
	MHN80a2	0.75	1.0	2940	83.5	1.6	0.8	2.44	6.5	14.7
	MHN90a2	1.1	1.5	2940	85.2	2.32	0.81	3.6	5.22	8.27
	MHN90b2	1.5	2.0	2900	86.5	3.25	0.78	5.0	4.79	9.83
4 POLI / POLES	MHN63a4	0.13	0.18	1400	70.9	0.38	0.73	0.88	3.6	6.5
	MHN63b4	0.18	0.25	1420	74.5	0.48	0.73	1.25	3.78	6.4
	MHN71a4	0.25	0.37	1440	77.9	0.56	0.81	1.7	3.7	7.2
	MHN71b4	0.37	0.5	1440	81.1	0.83	0.79	2.44	4.63	8.34
	MHN80a4	0.5	0.75	1450	83.2	1.24	0.71	3.3	5.25	8.43
	MHN80b4	0.75	1.0	1450	85.7	1.77	0.72	4.95	5.8	8.52
	MHN90a4	1.1	1.5	1440	87.2	2.28	0.79	7.3	4.2	8.9
	MHN90b4	1.5	2.0	1460	88.2	3.16	0.77	9.85	4.9	10.0
6 POLI / POLES	MHN63a6	0.09 ⁽¹⁾	0.12	900	61.5	0.3	0.7	0.95	2.2	3.2
	MHN63b6	0.13	0.18	880	65.9	0.42	0.69	1.41	2.5	3.3
	MHN71a6	0.18	0.25	890	70.1	0.53	0.7	1.95	2.6	3.0
	MHN71b6	0.25	0.37	890	74.1	0.72	0.69	2.65	3.2	3.4
	MHN80a6	0.37	0.5	890	78.0	0.98	0.7	3.97	1.7	3.4
	MHN80b6	0.5	0.75	900	80.3	1.25	0.72	5.3	2.4	3.7
	MHN90a6	0.75	1.0	950	82.7	1.65	0.77	7.6	2.6	5.7
	MHN90b6	1.1	1.5	950	84.5	2.4	0.78	11.1	2.9	6.1

(1): Classificazione IE non ancora disponibile

(1): IE classification not available yet.

ATTENZIONE: I dati tecnici riportati nella tabella si riferiscono ad una tensione di alimentazione di 230/400 V, 50 Hz.
Votaggi diversi solo su richiesta.

WARNING: Technical data reported in the table refer to voltage 230/400V, 50Hz.
Different voltages only on request.

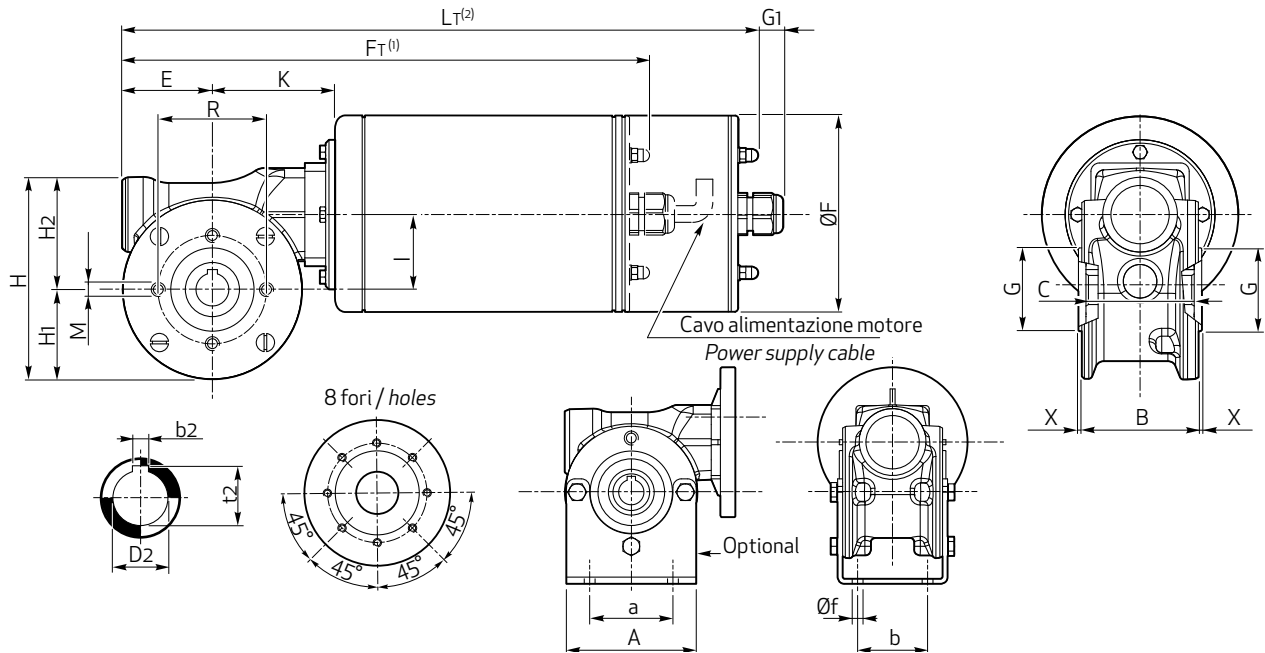

TAGLIA SIZE	A	a	B	b	b ₂	C	D ₂ H8	E	f	G _{H8}	H	H ₁	H ₂	I	K	M	R	t ₂	X
30	78	50	55	38	5	55	14	40	4xø6.5	50	93	40	53	30	63 - M63B14	4xM6x10	65	16.3	2
45	98	52	65	42	6	65	18	54.5	4xø8.5	50	127	54	73	45	74 - M63B14 71.5 - M71B14	4xM6x14	65	20.8	2
50	113	63	81	60	8	81	25	65	4xø8.5	68	140	59	81	50	78.5 - M63B14 76 - M71B14 76.5 - M80B14	4xM6x9	94	28.3	3
63	142	95	120	92	8	120	25	79	4xø10.5	75	173	72.5	100.5	63	97.5 - M71B14 99.5 - M80B14 99.5 - M90B14	8xM8x17	90	28.3	5
85	180	140	135	106	10	135	35	100	4xø11	110	234.5	97	137.5	85	118.5 - M80B14 118.5 - M90B14 127.5 - M100/112B14	8xM10x18	130	38.3	3.5

B14	TAGLIA RIDUTTORE / SIZE WORMGEARBOXES																
	30	45		50			63			85							
M flanges	M63	M71		M63	M71	M80		M71	M80	M90	M80	M90	M100 M112				
MHN	MHN63		MHN71	MHN63	MHN71	MHN80	MHN63	MHN71	MHN80	MHN71	MHN80	MHN71	MHN80	MHN90			
F	Ø118		Ø134	Ø118	Ø134	Ø150	Ø118	Ø134	Ø150	Ø134	Ø150	Ø134	Ø150	Ø190			
Ft ⁽²⁾	338	364	361	372	379	376	387	388	413	412	424	425	450	465	490	558	567
G1	16 (con pressacavo standard / with standard cable gland)																
Lt ⁽¹⁾	403	429	426	449	444	441	464	465	489	477	501	502	526	542	566	652	661

(1): Motore standard.

(2): Motore con opzioni aggiuntive.

(1): Standard motor.

(2): Motor with additional features.

Per informazioni più dettagliate, chiedere al nostro ufficio commerciale

For more detailed information, please contact our sales department



INOX

CHARACTERISTICS

CARATTERISTICHE



Linea di motori in acciaio inox con superficie completamente liscia (carcasa tubolare), sventilati e a profilo pulito, in grado di garantire il rispetto dei **più alti standard igienici** richiesti dal mercato.

La superficie di questi motori è **estremamente facile da pulire e resiste ai principali agenti aggressivi** utilizzati nella sanificazione degli impianti. Sono in grado di resistere in maniera eccellente alla corrosione e rappresentano una **soluzione affidabile e duratura** laddove l'igiene è un requisito fondamentale. Non vi sono zone che permettono l'accumulo di residui di polvere o di prodotti di lavorazione. Motori disponibili nella versione con il solo pressacavo o con il coperchio posteriore, all'interno del quale è possibile alloggiare la morsettiera, il freno o un encoder.

Grazie ad una **accurata progettazione a livello elettrico**, il riscaldamento è ridotto e la temperatura della superficie è contenuta. Inoltre, questi motori risultano particolarmente adatti per uso con inverter, in quanto realizzati con isolamenti che hanno superato i test delle microscariche.

Stainless steel motor line with completely smooth surface (tubular frame), without ventilation and capable of respecting and guaranteeing the **highest hygienic standards** demanded by the market.

The surface of these motors is **extremely easy to clean, and they withstand the most common aggressive agents** used to clean the main machinery. These motors excellently resist corrosion and represent a **reliable and long-lasting solution** in those areas where hygiene is a basic requirement. There isn't any area where leftovers of dust or processing residuals may accumulate. Stainless steel motors are available with a single cable gland or with the rear terminal box, where it is also possible to position a terminal block, brake or an encoder.

Thanks to an **accurate electrical design**, the internal heating and the surface temperature are limited. Moreover, these motors are particularly suitable to be used with an inverter, because they are made with superior class insulations.

DIMENSIONI

DIMENSIONS

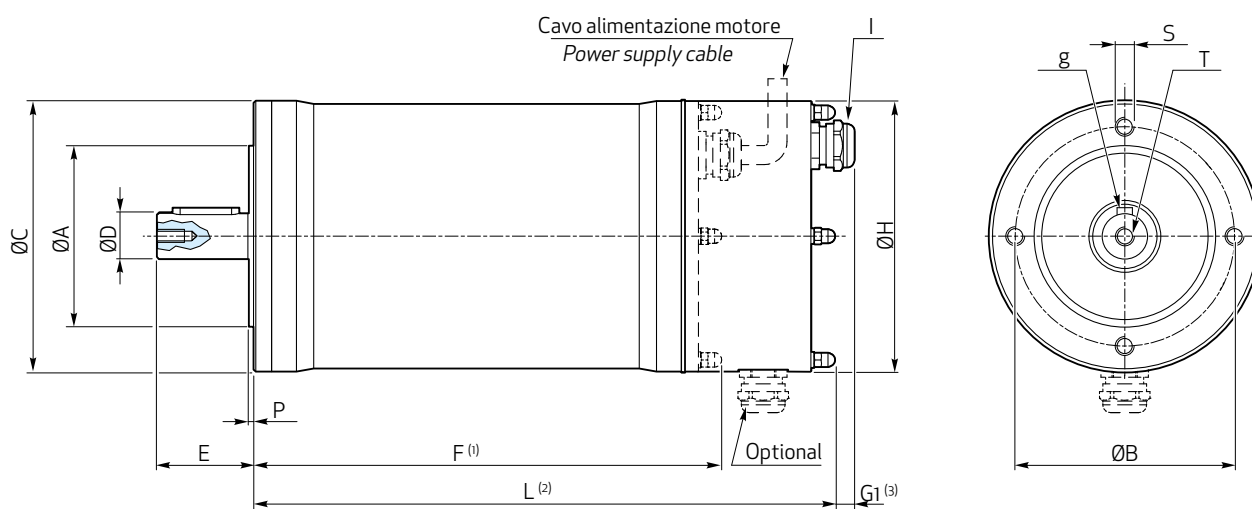

INOX	B14											B14 speciale / special											
	A j6	B	C	D j6	E	g	G1 (3)	F (1)	L (2)	H	I	P	S	T	A j6	B	C	D j6	E	g	P	S	T
MSS63	60	75	105	11	23	4		227	281	117		2.5	M5X9	M4	70	85	105	14	30	5	2.5	M6X10	M5
MSS80	80	100	120	19	40	6	16	246	306	143	M20X1.5	3	M8X12	M6	95	115	140	24	50	8	3	M8X12	M8
MSS90	95	115	140	24	50	8		300	370	182		3	M8X16	M8	110	130	160	28	60	8	3.5	M8X16	M10

(1): Motore standard.

(2): Motore con opzioni aggiuntive.

(3): Con pressacavo standard.

Flangia B5 disponibile su richiesta.

(1): Standard motor.

(2): Motor with additional features.

(3): With standard cable gland.

B5 flange available upon request.

DATI TECNICI

TECHNICAL DATA

IE4 Efficiency		Potenza nominale Nominal Power		Velocità Speed	Rendimento Efficiency	Corrente nominale Nominal Current	Fattore di potenza Power Factor	Coppia nominale Nominal Torque	Rapporti di spunto Starting Ratio	
		Pn		n	μ	An	Cos φ	Cn	Cs/Cn	As/An
Tipo Type		[kW]	[Hp]	[rpm]	[%IE4]	[A]	-	[Nm]	-	-
2 POLI / POLES	MSS63a2	0.13	0.18	2890	66.5	0.37	0.73	0.43	5.0	7.56
	MSS63b2	0.18	0.25	2850	70.8	0.43	0.81	0.61	3.6	6.36
	MSS63c2	0.25	0.37	2880	74.3	0.58	0.81	0.84	4.5	7.9
	MSS80a2	0.37	0.5	2940	78.1	0.81	0.83	1.21	5.8	12.0
	MSS80b2	0.5	0.75	2940	80.8	1.1	0.82	1.63	5.5	13.4
	MSS80c2	0.75	1.0	2940	83.5	1.6	0.8	2.44	6.5	14.7
	MSS90a2	1.1	1.5	2930	85.2	2.32	0.81	3.6	5.22	8.27
	MSS90b2	1.5	2.0	2900	86.5	3.25	0.78	5.0	4.79	9.83
4 POLI / POLES	MSS63a4	0.13	0.18	1420	70.9	0.37	0.73	0.88	3.6	6.5
	MSS63b4	0.18	0.25	1420	74.7	0.48	0.73	1.22	4.0	6.3
	MSS63c4	0.25	0.37	1410	77.9	0.62	0.75	1.7	3.5	5.6
	MSS80a4	0.37	0.5	1450	81.1	0.85	0.76	2.5	4.4	8.2
	MSS80b4	0.5	0.75	1440	83.2	1.15	0.76	3.3	5.8	9.3
	MSS80c4	0.75	1.0	1440	85.7	1.7	0.75	5.0	6.0	9.0
	MSS90a4	1.1	1.5	1450	87.2	2.31	0.78	7.22	4.53	9.0
	MSS90b4	1.5	2.0	1440	88.2	3.01	0.83	9.9	4.0	8.3
6 POLI / POLES	MSS63a6	0.09 ⁽¹⁾	0.12	900	61.5	0.3	0.7	0.95	2.2	3.2
	MSS63b6	0.13	0.18	880	65.9	0.42	0.69	1.41	2.5	3.3
	MSS63c6	0.18	0.25	850	70.1	0.53	0.7	1.95	2.6	3.0
	MSS80a6	0.25	0.37	900	74.1	0.7	0.7	2.65	3.2	3.4
	MSS80b6	0.37	0.5	890	78.0	0.98	0.7	3.97	1.7	3.4
	MSS80c6	0.5	0.7	900	80.3	1.25	0.72	5.3	2.4	3.7
	MSS90a6	0.75	1.0	950	82.7	1.7	0.77	7.6	2.5	5.7
	MSS90b6	1.1	1.5	950	84.5	2.4	0.78	11.1	2.9	6.1

(1): Classificazione IE non ancora disponibile

(1): IE classification not available yet.

ATTENZIONE:

I dati tecnici riportati nella tabella si riferiscono ad una tensione di alimentazione di 230/400 V, 50 Hz.
Votaggi diversi solo su richiesta.

WARNING:

Technical data reported in the table refer to voltage 230/400V, 50Hz.
Different voltages only on request.

MOTORIDUTTORI A VITE SENZA FINE

WORMGEARMOTORS

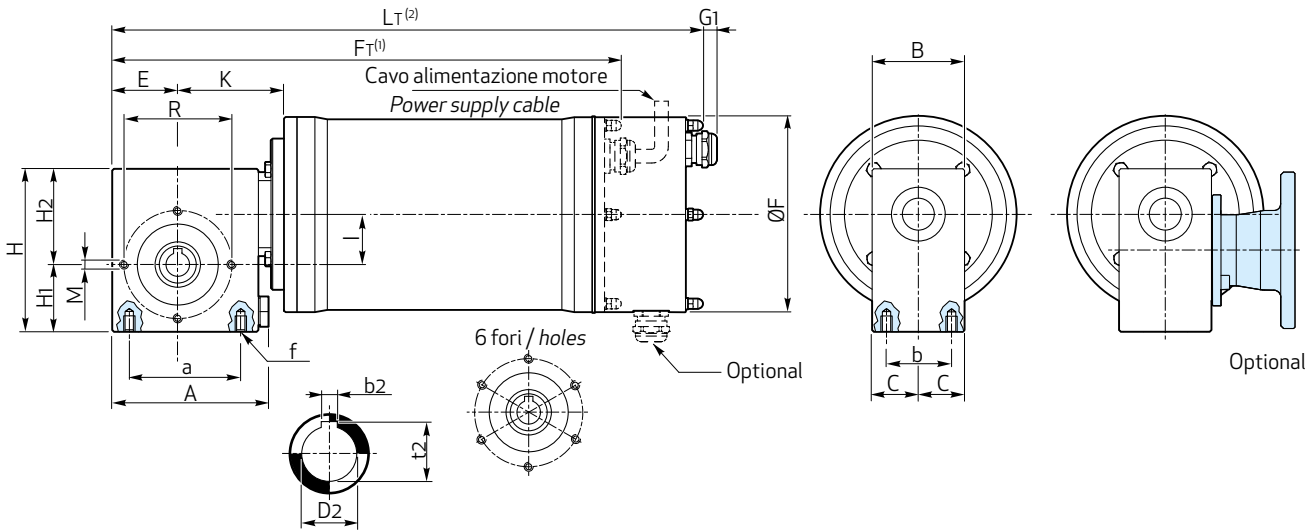

TAGLIA SIZE	A	a	B	b	b ₂	C	D ₂ H8	E	f	H	H ₁	H ₂	I	K	M	R	t ₂
30	93	66	55	38	5	27.5	14	39	M8x11	97	40	57	30	62.5 - M63B14	4xM6x7	64	16.3
45	116.5	86	65	42	6	32.5	18	55	M8x11	128	55	73	45	73.3 - M63B14 71 - M71B14	4xM6x11	64	20.8
50	134	102	81	60	8	40.5	25	68	M8x11	141	60	81	50	78 - M63B14 71 - M71B14 76 - M80B14	6xM6x9	75	28.3
63	162	128	120	92	8	60	25	77	M10x17	175	75	100	63	97 - M71B14 98 - M80B14 99 - M90B14	4xM8x11	92	28.3
85	208	164	135	106	10	67.5	35	103	M12x19	232	94.5	137.5	85	127 - M100 / 112 B14	6xM8x11	120	38.3
110	242	200	140	105	12	70	42	117.5	M14x21	280	117.5	162.5	110	146.5 - M100 / 112 B14	6xM12x19	140	45.3

B14	TAGLIA RIDUTTORE / SIZE WORMGEARBOXES											
	30	45		50			63			85	110	
M flanges	M63	M71	M63	M71	M80	M71	M80	M90	M100 - M112	M100 - M112		
MSS	MSS63				MSS80	MSS63	MSS80		MSS90			
F	Ø117				Ø143	Ø117	Ø143		Ø182			
F _T ⁽¹⁾	329	356	353	373		395	401	426	427	476	530	564
G ₁	16 (con pressacavo standard / with standard cable gland)											
L _T ⁽²⁾	380	407	404	424		447	452	478	479	542	596	630

(1): Motore standard.

(2): Motore con opzioni aggiuntive.

(1): Standard motor.

(2): Motor with additional features.

Per informazioni più dettagliate, chiedere al nostro ufficio commerciale

For more detailed information, please contact our sales department



via 2 Agosto 1980, 5
40016 S. Giorgio di Piano
Bologna - Italy

Tel. +39 051 8902811
Fax +39 051 6651043
info@carpanelli.net



www.carpanelli.net